

3.1 - Discrete I/O IP 20 modules

Selection guide distributed I/O system page 3/2

Selection guide TBX distributed discrete I/O modules page 3/4

■ TBX distributed discrete I/O modules page 3/6

Selection guide TBX distributed analog I/O modules page 3/20

■ TBX distributed analog I/O modules page 3/22

3.2 - IP 65/67 splitter boxes and modules

Selection guide splitter boxes and modules page 3/26

■ TBX discrete I/O IP 65 modules on Fipio bus page 3/28

■ Discrete I/O IP 67 modules on Fipio bus page 3/34

■ Discrete I/O IP 65 modules on INTERBUS bus page 3/44

Modicon Premium automation platform

Distributed I/O systems

3
3.1

Applications

TBX distributed I/O



Type of bus or network

Fipio

Max. number per connexion points

1 monobloc module

2 base units

Max. number of connexion points

127

Discrete inputs/outputs	Number of channels
	Input voltage
	Output voltage

16 I et 16 O
≡ 24 V
≡ 24 V and relay

16 I, 12 O, 16 O, 8 I/8 O et 8 I/2 O
≡ 24 V, ≡ 48 V et ~ 120 V
≡ 24 V, ~ 120 V and relay

Analogue inputs/outputs

–

Base units 4 I, 2 O et 6 I/2 O

Counting

–

Other types

–

Type of distributed I/O

TBX C●P

TBX D●S

Pages

3/14 and 3/25

Momentum distributed I/O



Ethernet
Modbus Plus
Fipio
DeviceNet
Profibus DP
INTERBUS

1 base

126 to 512 points depending on the type of bus or network

16 I, 32 I, 8 O, 16 O, 32 O, 10 I/8 O, 16 I/8 O, 16 I/12 O et 16 I/16 O

≡ 24 V, ~ 120 V and ~ 230 V

≡ 24 V, ~ 120 V and ~ 230 V and relaiy

Bases 4 I, 8 I, 16 I and 4 O

Base 2 channels 10 kHz/200 kHz

6 I/3 O ~ 120 V and 1 Modbus port module
M1 processeur module (programming under Concept or ProWORX)

170 AD●

Consult our catalogue "Momentum automation platform"

Advantys STB distributed I/O solution



Ethernet
CANopen
Modbus Plus
Fipio
DeviceNet
Profibus DP
INTERBUS

32 modules

2 I, 4 I, 6 I, 2 O, 4 O, 6 O

≡ 24 V, ~ 115 V and ~ 230 V

≡ 24 V, ~ 115/230 V and relay

Modules 2 I and 2 O

Module 1 channel 40 kHz

Parallel interface module for Tego Power applications
Parallel interface module for TeSys modèle U starter-controllers

STB D●●/A●●

Consult our catalogue "Advantys STB distributed I/O"

Modicon Premium automation platform

TBX distributed discrete I/O modules

3
3.1

Applications Distributed discrete inputs on Fipio bus



Degree of protection IP 20

Voltage	☰ 24 V	☰ 48 V	~ 120 V
	-		-
Output current	-		

Modularity	16 channels	16 channels (transistors)
	-	32 channels maximum per connection point
Possible extension	-	

Proximity sensor compatibility IEC 1131	Type 1	Type 2
--	--------	--------

Protection against overloads

Additional functions	Wiring check	-	Integrated	-	
	Output fallback	-	-	-	
	Programmable filter	-	-	Integrated	-
	Latching states	-	-	Integrated	-

Type of modules	TBX CEP 1622	TBX DES 1622	TBX DES 16C22	TBX DES 16F22	TBX DES 1633	TBX DES 16S04
------------------------	--------------	--------------	---------------	---------------	--------------	---------------

Pages 3/14

Distributed discrete outputs on Fipio bus



Distributed discrete I/O on Fipio bus

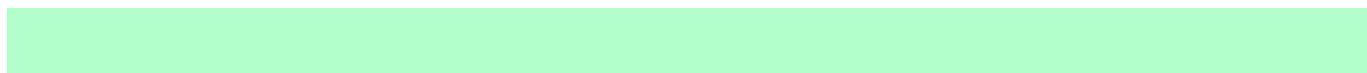

\sim 24 V 0.5 A	\sim 24/240 V			Inputs \sim 24 V Outputs \sim 24 V			Inputs \sim 24 V Outputs \sim 24/240 V, \sim 24 V		Inputs \sim 120 V Outputs \sim 120 V	
	\sim 24 V 16 "F" 50 VA	\sim 24/48 V 12 "F" 100 VA	\sim 24 V 16 "F" 50 VA	0.5 A	2A	0.5A	2 "F" 50 VA	8 "F" 50 VA	8 "F" 100 VA	

16 channels (transistors)		16 channels (Relay)	12 channels (Relay)	16 channels (Relay)	8 channels Inputs/ 8 channels Outputs (transistors)	16 channels I/O programmables	8 Inputs channels 2 Outputs channels (Relay)	8 Inputs channels 8 Outputs channels (Relay)	8 Inputs channels 8 Outputs channels (Relay)
-	32 channels maxi per connection point	-	24 ou 32 channels maxi per connection point		32 ou 20 channels maxi per connection point				

Type 2

Protected	Not Protected			Protected	Not Protected		Protected
-----------	---------------	--	--	-----------	---------------	--	-----------

-	Integrated	-	Integrated	-
-	Integrated	Integrated		
-				
-				

TBX CSP 1622	TBX DSS 1622	TBX DSS 16C22	TBX CSP 1625	TBX DSS 1235	TBX DSS 1625	TBX DMS 16C22	TBX DMS 16C222	TBX DMS 16P22	TBX DMS 1025	TBX DMS 1625	TBX DMS 16S44
--------------	--------------	---------------	--------------	--------------	--------------	---------------	----------------	---------------	--------------	--------------	---------------

3
3.1

General, functions

Decentralising I/O meets the requirements of both users and machine manufacturers while maintaining performance comparable with that of a centralised structure:

- The volume of wiring associated with discrete and analog sensors and actuators is reduced.
- Mechanical constraints associated with wiring ducts are eliminated.
- The time required for designing and testing connections is reduced.
- Machine or plant availability is maximised.
- Installations are more flexible and meet requirements more closely due to the number and type of modules.
- Protection for use in harsh environments, TBX IP 65 dust and damp proof models.

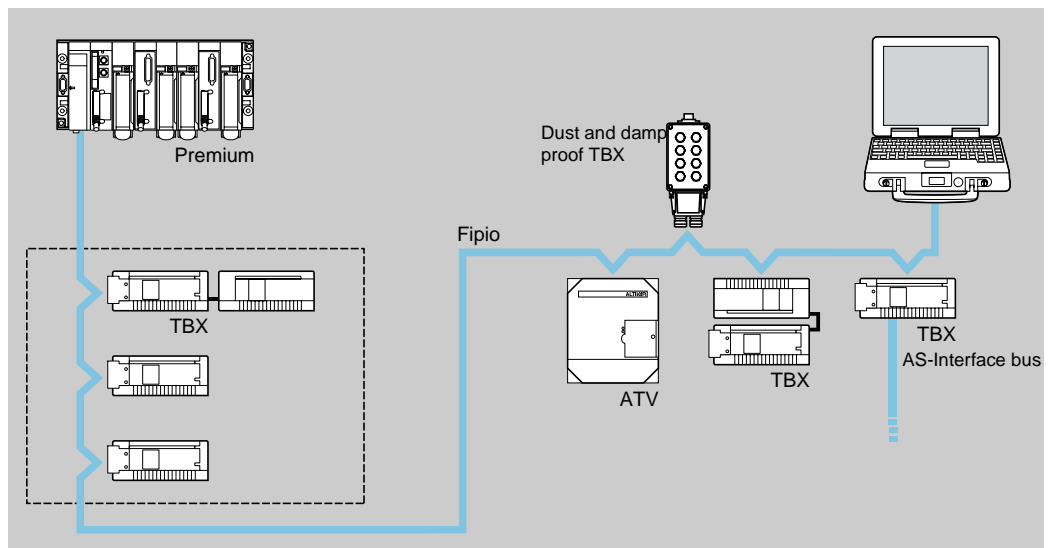

TBX distributed I/O modules, dust and damp proof or not, are a simple response to control system architectures distributed on a fieldbus. They are integrated into Schneider Electric PLC X-Way communication architectures by means of the Fipio fieldbus, which conforms to the Fip standard.

TBX distributed I/O modules are addressed by the PL7 application program as "In-rack" I/O, with which they can coexist.

TBX distributed I/O modules are connected to Premium bus manager processors or Atrium PCX coprocessors via the Fipio fieldbus (maximum number of modules per Fipio bus, see page 5/92).

The range of TBX distributed I/O modules includes the following modules:

- Monobloc or modular discrete I/O modules (IP 20), see page 3/14.
- Dust and damp proof monobloc discrete I/O modules (IP 65), see page 3/32.
- Dust and damp proof discrete I/O modules (IP 67), see page 3/42.
- Modular analog I/O modules (IP 20), see page 3/25.

TBX monobloc and modular modules IP 20

Protection of transistor and triac outputs

All transistor outputs have a protection mechanism which detects an overload or a short-circuit on the load when an output is active. This type of fault is displayed and deactivates the output. This fault is accessible to the application program when testing the fault bits.

Reactivating transistor and triac outputs

When an output is no longer active following a fault, it must be reset in order to reactivate it. It can be reactivated automatically or via a command from the application program, depending on the selection made during the software configuration.

TBX modular modules IP 20

TBX modular discrete modules have many functions, which are defined in the table below:

TBX reference	DES 16C22 DES 16S04	DSS 16C22	DES 16F22	DMS 16P22	DSS 1622 DSS 1235/1625 DMS 1025/1625 DMS 16S44	DMS 16C22 DMS 16C222
Wiring check						
Programmable filtering						
Latching states						
Configuration of channels as I or O						
Output fallback						
Assignment of channels to application tasks						

Function available

Input wiring check

The input wiring check function continuously checks the quality of the connection between the sensor and the distributed I/O module and discriminates between a closed or open state of the sensor and a short-circuit or open circuit. When a fault appears, the fault bit for the channel is activated before changing the input to state 0. After the fault has disappeared, if the sensor is closed, the input changes to state 1 before the fault bit is deactivated.

The input wiring can be enabled as required for each channel during software configuration.

Output wiring check

The output wiring check function continuously checks the quality of the connection between the actuator and the module and detects a faulty actuator or its connection (open circuit or short-circuit).

The output wiring check can be enabled as required for each channel during software configuration.

Programmable filtering

This function offers the possibility to choose, during software configuration, the filtering to be assigned to the inputs : normal or fast. Filtering can be configured for groups of 8 channels (channels 0 to 7 or channels 8 to 15).

Fast filtering is analog, with a typical value of 0.7 ms.

Normal filtering is provided by a digital filter of 5 ms in conjunction with an analog filter of 0.7 ms. By default, inputs are configured for fast filtering.

Latching stats

This function enables pulses lasting more than 2 ms on a rising edge to be recognised. This information is latched during a PLC scan in order to be processed in the PL7 application program.

Configuring the channels as input or output

This function enables the channels to be defined as input channels or output channels. This can be:

16 inputs maximum and 0 output (this is the default configuration),

15 inputs and 1 output,

8 inputs and 8 outputs.

Output fallback

All modular TBX module outputs can be set to a specific state on a fault. Several choices are possible:

Fallback to 0 (default fallback position),

Fallback to 1,

Maintain state: the output maintains the state (1 or 0) which it was at when the fault occurred,

Fallback value defined by the user program.

This choice is made for groups of 8 channels (channels 0 to 7 or channels 8 to 15) during software configuration.

Assigning module channels to several tasks

Each base unit is functionally divided into groups of 8 consecutive channels (channels 0 to 7 and channels 8 to 15), called functional channel groups. Each channel group in a TBX module can be assigned, during software configuration, to a specific application task (fast, master or auxiliary task).

Modicon Premium automation platform

TBX distributed discrete I/O modules

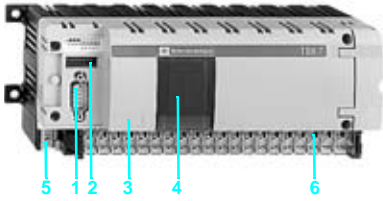

Monobloc distributed I/O modules IP 20

TSX CEP/CSP monobloc I/O modules comprise:

- 1 A 9-way male SUB-D connector for connection to the Fipio bus via a TBX BLP 01 connector.
- 2 5 dip switches for coding the Fipio address together with an address coding label.
- 3 A location for the user's module/connection point identification label.
- 4 An I/O display window.
- 5 A screw clamp for earthing the module.
- 6 A removable screw terminal block (with terminal label) for wiring the sensors, preactuators and power supplies.

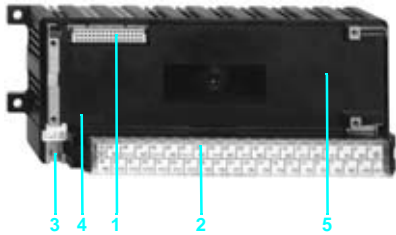

Modular distributed I/O modules IP 20

Base units

The base units are designed to be used with:

- A TBX LEP 020/030 communication module to constitute a base module.
 - A TBX CBS 010 cover and cable to constitute an extension module.
- They enable direct connection of sensors and preactuators. They are available as input base units, reference TBX DES ●●●, output base units, reference TBX DSS ●●● and mixed base units, reference TBX DMS ●●●.

TBX DES/DSS/DMS modular I/O base units comprise:

- 1 A female 1/2 DIN connector for connection to the TSX LEP 020/030 communication module.
- 2 A removable screw terminal block (with terminal label) for wiring the sensors, preactuators and power supplies.
- 3 A screw clamp for earthing the base unit.
- 4 A location for the user's station/module identification label.
- 5 An access flap to 2 dip switches for adjusting the leakage current for the wiring check and the filter times (slow or fast).



Fipio bus communication modules

The TBX LEP 020/030 communication modules enable dialogue with the PLC via the Fipio bus. They are fixed to the base unit by 4 screws. A female 1/2 DIN connector, protected by a flap, is used for connection to the extension base unit.

The Fipio address is assigned using 6 dip switches.

An I/O display window indicates locally the state of the module and of the base unit and the extension I/O.

TBX LEP 020/030 communication modules comprise:

- 1 A 9-way male SUB-D connector for connection to the Fipio bus via a TBX BLP 01 connector.
- 2 5 dip switches for coding the Fipio address together with an address coding label.
- 3 A location for the user's module/connection point identification label.
- 4 An I/O display window.
- 5 An access flap for the female 1/2 DIN connector for connecting the extension base unit.

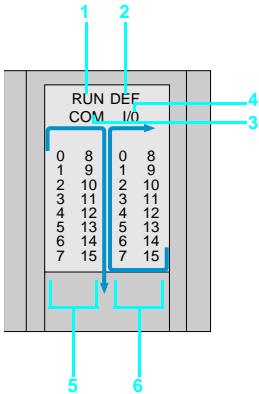

I/O display window

Each monobloc I/O module and communication module has an I/O display window which contains all the information to be displayed:

- 1 A RUN lamp (green), device operating.
- 2 A DEF lamp (red), steady if the device is faulty, flashing if there is a communication fault on the Fipio bus.
- 3 A COM lamp (yellow), Fipio frame sent and received.
- 4 An I/O lamp (red), sensor or preactuator fault (short-circuit, open circuit, loss of voltage).
- 5 Sixteen lamps 0 to 15 (red), steady when channel active, flashing if channel faulty.
- 6 Sixteen lamps 0 to 15 (red), steady when channel active, flashing if channel fault (corresponds to extension module channels).

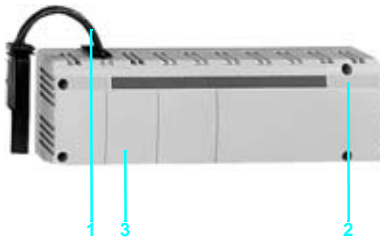

Cover and cable for extension base units

The TBX CBS 010 comprises a cover and a connecting cable. The cable connects the extension base unit to the communication module. The cover, attached to the base unit by 4 screws, protects the connector and gives the extension module (base unit and cover) a similar size and shape to that of the base module.

The TBX CBS 010 cover and cable unit comprises:

- 1 A flexible connecting cable with two male 1/2 DIN moulded connectors for connecting the TBX LEP 020/030 communication module to the base unit.
- 2 A cover to be fixed to the base unit.
- 3 A location for the user's module/connection point identification label.



Process power supply unit

For sites which do not have a ± 24 V power supply, the TBX SUP 10 power supply module is available which, from a $\sim 100/240$ V 50/60 Hz or $\pm 110/125$ V supply, provides ± 24 V $\pm 5\%$ at 1 A. This power supply is protected against short-circuits, overloads and overvoltages.

The TBX SUP 10 power supply comprises:

- 1 A screw connector terminal block, mains supply and ± 24 V output.
- 2 A lamp (green), supply present.

Main characteristics

Nominal input voltage	V	$\sim 100...240$ ou ± 125
Input voltage range	V	$\sim 90...264$ ou $\pm 88...156$
Permitted duration of micro-break (1)	ms	≤ 10 en \sim , ≤ 1 en \pm
Mains frequency	Hz	47...63
Nominal input current	A	0.4
Inrush current	A	< 30
Nominal output current at 60 °C	A	1
Output voltage (0 to 60 °C)	V	$24 \pm 5\%$
Protection against short-circuits		Continuous/automatic restart
Internal/external overvoltages	V	36

(1) At nominal voltage for a repetition period of 1 Hz.

Type of modules			TBX DES 1622	TBX DES 16C22	TBX DES 16F22
Modularity			16	16	16
Nominal input values	Voltage	V	~ 24	~ 24	~ 24
	Current	mA	15	7	7
	Sensor supply (ripple included)	V	~ 19...30	~ 19...30	~ 19...30
Input limit values	At state 1	Voltage	V	≥ 11	≥ 11
		Current	mA	≥ 6 for 11 V	≥ 6 for 11 V
	At state 0	Voltage	V	< 5	< 5
		Current	mA	≤ 2	≤ 2
Input impedance			kΩ	1.6	3.4
Logic			Positive	Positive	Positive
Response time	Change from 0 to 1	Fast filter	ms	–	5...8.5
		Slow filter	ms	7...15.5	30...45
	Change from 1 to 0	Fast filter	ms	–	5...8.5
		Slow filter	ms	7...15.5	30...45
Protection against polarity inversion			Sensor supply	Reverse parallel diode	
Dissipated power			Per module (with 60 % load)	W	4.1
Typical current consumed	Module supply	mA	20	40 (+10 if extension)	40 (+10 if extension)
	Sensor supply	mA	150	70	70
Type of input			Resistive, conforms to IEC 1131 type 2	Current sink, conforms to IEC 1131 type 2	
Sensor common			To "+ve" of supply		
Compatible output modules			TBX transistor outputs	TBX transistor outputs (2)	TBX transistor outputs
External line	Line resistance	W	< 500 with volt-free contact, < 100 with 2-wire proximity sensor		
	Open line leakage resistance	kΩ	> 30 with volt-free contact, > 100 with 2-wire proximity sensor		
Isolation	Dielectric strength between inputs and earth	Veff	1500 at 50/60 Hz for 1 min		
	Insulation resistance	MΩ	> 10 at ~ 500 V		

Type of modules			TBX CEP 1622	TBX DES 1633	TBX DES 16S04
Modularity			16	16	16
Nominal input values	Voltage	V	~ 24	~ 48	~ 120
	Current	mA	7	7	15
	Sensor supply (ripple included)	V	~ 19...30	~ 38...60	~ 93...132
Input limit values	At state 1	Voltage	V	> 7	> 30
		Current	mA	≥ 2 for 11 V	≥ 6 for 30 V
	At state 0	Voltage	V	< 5	< 10
		Current	mA	≤ 1.4	≤ 2
Input impedance			kΩ	3.4	6.7
Logic			Positive	Positive	Positive
Response time	Change from 0 to 1	ms	5...11	5...11	5
	Change from 1 to 0	ms	5...13	5...13	5
Protection against polarity inversion	Module supply		Series diode	–	–
	Sensor supply		Reverse parallel diode		–
Dissipated power			Per module (with 60 % load)	W	3.9
Typical current consumed	Module supply	mA	90	20	60
	Sensor supply	mA	70 (with 60 % load)		
Type of input			Resistive, conforms to IEC 1131 type 1	Current sink, conforms to IEC 1131 type 2	
Sensor common			To "+ve" of supply		
Compatible output modules			TBX transistor outputs		
External line	Line resistance	W	< 500 with V-free contact		
	Open line leakage resistance	kΩ	> 50 with V-free contact > 200 with 2-wire prox. sensor		
Isolation	Dielectric strength between inputs and earth	Veff	1500 at 50/60 Hz for 1 min		
	Insulation resistance	MΩ	>10 at ~ 500 V		

(1) Normal or fast programmable filter.

(2) Only with transistor outputs having wiring check function.

Type of modules			TBX CSP 1622	TBX DSS 1622	TBX DSS 16C22	
Modularity			16	16	16	
Loads	Voltage	V	≐ 24	≐ 24	≐ 24	
	Nominal current	A	0.5	0.5	0.5	
	Tungsten filament lamp	W	8	8	8	
Limit values	Voltage (ripple included)	V	≐ 19...30	≐ 19...30	≐ 19...30	
Logic			Positive outgoing current			
Response time	Change from 0 to 1	ms	≤ 1	≤ 1	≤ 1	
	Change from 1 to 0	ms	≤ 1	≤ 1	≤ 1	
Leakage current	At state 0	mA	< 0.5	< 0.5	< 2	
Residual voltage	At state 1	V	< 0.4	< 0.4	< 0.4	
Built-in protection	Against overloads		Yes (thermal)			
	Against overvoltage		Zener diode			
	Against polarity inversion		Reverse parallel diode			
Load common			To “-ve” of supply			
Typical current consumed	Module supply	mA	100	30	30	
	Alimentation préactionneurs	mA	35 (except active outputs)		45 (exc. active outplus)	
Dissipated power	Per module (with 60 % load)	W	5.7	4.1	4.3	
Compatibility input modules	d.c.		Yes	Yes	Yes	
Load impedance	At state 1	W	> 50	> 50	50 < z < 3000	
Isolation	Dielectric strength between inputs and earth	Veff	1500 at 50/60 Hz for 1 min			
	Insulation resistance	MΩ	> 10 at ≐ 500 V			
Type of modules			TBX CSP 1625	TBX DSS 1235	TBX DSS 1625	
Modularity			16	12	16	
Loads	Voltage	V	~ 24...264 ≐ 24	~ 24...264 ≐ 24...48	~ 24...264 ≐ 24	
	Permissible d.c. power	DC-12 resistive	W	24 0.2x10 ⁶ operation	50...24 V 0.25x10 ⁶ operation 50...48 V 0.5x10 ⁶ operation	24 0.2x10 ⁶ operation
		DC-13 inductive	W	10 10 ⁶ operation	25...24 V 0.25x10 ⁶ operation 25...48 V 0.15x10 ⁶ operation	10 10 ⁶ operation
	Permissible a.c. current	AC-12 resistive	A	1-110/220 V 0.2x10 ⁶ operation 0.5-110/220 V 2x10 ⁶ operation 1-24/48 V 0.5x10 ⁶ operation 2-24 V 0.2x10 ⁶ operation	2-110/220 V 0.5x10 ⁶ oper. 1-110/220 V 1.5x10 ⁶ oper. 2-24/48 V 0.5x10 ⁶ oper. 4-24 V 0.15x10 ⁶ operation	1-110/220 V 0.2x10 ⁶ oper. 0.5-110/220 V 2x10 ⁶ oper. 1-24/48 V 0.5x10 ⁶ operation 2-24 V 0.2x10 ⁶ operation
		AC-15 inductive	A	0.5-24/48 V 10 ⁶ operation 1-24 V 0.2 10 ⁶ operation	1-24/48 V 10 ⁶ operation 0.5-48 V 2x10 ⁶ operation (1)	0.5-24/48 V 10 ⁶ operation 1-24 V 0.2 10 ⁶ operation (2)
Thermal current		A	3	7	3	
Typical current consumed	Module supply (with 60 % load)	mA	195	130...24 V 70...48 V	125	
Response time	Change from 0 to 1	ms	< 10	< 10	< 10	
	Change from 1 to 0	ms	< 20	< 20	< 20	
Built-in protection	Against overloads and short -circuits		No			
	Against inductive overvoltage		No (for ~ use an RC or GMOV, and for ≐ use a reverse diode)			
Compatibility input modules	d.c.		Yes			
Isolation	Dielectric strength between inputs and earth	Veff	1500 at 50/60 Hz for 1 min			
	Insulation resistance	MΩ	> 10 at ≐ 500 V			

(1) 100 VA - 110/240 V 10⁶ operations, 20 VA - 110/240 V 5X10⁶ operations.
(2) 50 VA - 110/220 V 10⁶ operations, 10 VA - 48/220 V 10⁷ operations.

3
3.1

Type of modules			TBX DMS 1025	TBX DMS 1625	TBX DMS 16S44		
Input modularity			8	8	8		
Nominal input values	Voltage	V	--- 24	--- 24	~ 120		
	Current	mA	15	15	15		
	Sensor supply (ripple included)	V	19.2...30	19.2...30	92...132		
Input limit values	At state 1	Voltage	V	≥ 11	> 74		
		Current	mA	≥ 6 for 11 V	≥ 6 for 11 V	6	
	At state 0	Voltage	V	< 5	< 5	< 20	
		Current	mA	≤ 2	≤ 2	4	
Input impedance			kΩ	1.6	1.6	10	
Logic				Positive	Positive	Positive	
Response time	Change from 0 to 1			5...15	5...15		
	Change from 1 to 0			5...17	5...17		
Dissipated power	Per module (with 60 % load)		W	2.6	3.7	6	
	Typical current consumed						
Module supply			mA	35 (+10 if extension)	80 (+10 if extension)	60	
Sensor supply			mA	75	75	75	
Type of input			Resistive, conforms to standard IEC 1131 type 2				
Sensor common			To "+ve" of supply				
Compatible output modules			TBX transistor outputs				
External line	Line resistance		kW	< 500 with volt-free contact, < 100 with 2-wire proximity sensor			
	Open line leakage resistance		kΩ	> 30 with volt-free contact, > 100 with 2-wire proximity sensor			
Outputs modularity			2	8	8		
Loads	Voltage		V	~ 24...264 --- 24	~ 24...264 --- 24	~ 93...132	
	Permissible d.c. power	DC 12 resistive	W	24 0.2x10 ⁶ operation		–	
		DC 13 inductive	W	10 10 ⁶ operation		–	
	Triac		W	–		95 per output at 60° C1 at 25° C	
	Relay	Permissible a.c. current	AC 12 resistive	A	1 - 110/220 V 0.2x10 ⁶ operating cycles 0.5 - 110/220 V 2x10 ⁶ operating cycles 1 - 24/48 V 0.5x10 ⁶ operating cycles 2 - 24 V 0.2x10 ⁶ operating cycles		–
			AC 15 inductive	A	0.5 - 24/48 V 10 ⁶ operating cycles 1 - 24 V 0.2 10 ⁶ operating cycles		–
	Thermal current		A	3	3	–	
Response time	Change from 0 to 1		ms	≤ 10	≤ 10	≤ 80	
	Change from 1 to 0		ms	≤ 20	≤ 20	≤ 20	
Built-in protection	Against overloads and short -circuits			No	No	Yes	
	Against inductive overvoltage			No (for ~ use RC or GMOV, and for --- use a reverse diode)			
Compatibility input modules			d.c.	Yes		No	
Isolation	Dielectric strength between inputs and earth		Veff	1500 at 50/60 Hz for 1 min			
	Insulation resistance		MΩ	> 10 at --- 500 V			

(1) 50 VA - 110/220 V 10⁶ operating cycles, 10 VA - 48/220 V 10⁷ operating cycles.

Type of modules			TBX DMS 16C22	TBX DMS 16C222	TBX DMS 16P22		
Input modularity			8	8	8...16		
Nominal input values	Voltage	V	≐ 24	≐ 24	≐ 24		
	Nominal current	mA	7	7	15		
	Sensor supply (ripple included)	V	≐ 19.2...30	≐ 19.2...30	≐ 19.2...30		
Input limit values	At state 1	Voltage	V	≥ 7	≥ 11		
		Current	mA	≥ 6 for 7 V	≥ 6 for 11 V		
	At state 0	Voltage	V	< 5	< 5		
		Current	mA	≤ 2	≤ 2.5		
Input impedance			kΩ	3.4	3.4		
Logic				Positive	Positive		
Response time	Change from 0 to 1	Fast filter	ms	5...8.5	5...8.5		
		Slow filter	ms	30...45	30...45		
	Change from 1 to 0	Fast filter	ms	5...8.5	5...8.5		
		Slow filter	ms	30...45	30...45		
Protection against polarity inversion			Sensor supply	Diode inverse en parallèle			
Dissipated power			Per module (with 60 % load)	W	3.4	8.1	6.5
Typical current consumed	Module supply		mA	40 (+ 10 if extension)	45 (+ 10 if extension)	30	
	Sensor supply		mA	35	35	75	
Type of input				Current sink, conforms to IEC 1131 type 2	Resistive, conforms to IEC 1131 type 2		
Input common			To "+ve" of supply				
Compatible output modules			TBX transistor outputs				
External line	Line resistance		kΩ	< 500 with volt-free contact < 100 with 2-wire proximity sensors			
	Open line leakage resistance		kΩ	200 or 500	> 30 with 2-wire prox. sen. > 100 with 2-wire prox. sen.		
Outputs modularity			8	8	0...8		
Loads	Voltage	V	≐ 24	≐ 24	≐ 24		
	Nominal current	A	0.5	2 (1)	0.5		
	Tungsten filament lamp	W	8	15	8		
Limit values			Voltage (ripple included)	V	≐ 19...30	≐ 19...30	
Logic				Positive	Positive		
Response time	Change from 0 to 1		ms	≤ 1.5	≤ 1		
	Change from 1 to 0		ms	≤ 1.5	≤ 1		
Leakage current			At state 0	mA	< 2.3	< 2.5	< 0.5
Residual voltage			At state 1	V	< 0.4	< 0.8	< 0.4
Built-in protection	Against overloads			Yes (thermal)	Yes (current limitation)	Yes (thermal)	
	Against overvoltage			Yes (Zener diode)	Yes (Zener diode)	Yes (Zener diode)	
	Against polarity inversion			Yes (reverse diode)	Yes (reverse diode)	Yes (reverse diode)	
Load common			To "-ve" of supply				
Compatibility input modules			d.c.	Yes (if $z < 3 \text{ k}\Omega$)	Yes		
Load impedance			At state 1	W	$50 < z < 3000$	> 50	
Isolation	Dielectric strength between inputs and earth		Veff	1500 at 50/60 Hz for 1 min			
	Insulation resistance		MΩ	> 10 at ≐ 500 V			

(1) Temperature derating: total output current per base unit 16 A at 30 °C, 8 A at 60 °C.

Modicon Premium automation platform

TBX distributed discrete I/O modules



TBX CoP 16



TBX DES 16



TBX DSS 16

Monobloc input module (IP 20)

Type of current	Input voltage	Modularity (no. of chan.)	IEC 1131 2 conformity	Reference	Weight kg
---	24 V	16	Type 1	TBX CEP 1622	0.820

Monobloc output modules (IP 20)

Type of current	Output voltage	Modularity (no. of chan.)	Channel characteristics	Reference	Weight kg
transistor	24 V	16	0.5 A protected	TBX CSP 1622	0.880
~ ou --- relay	~ 24/240 V --- 24 V	16	50 VA not protected	TBX CSP 1625	0.960

Input base units (IP 20) (1)

Type of current	Input voltage	Modularity (no. of chan.)	IEC 1131 2 conformity	Reference	Weight kg
---	24 V	16	Type 2	TBX DES 1622	0.510
		16, wiring check function	Type 2	TBX DES 16C22	0.510
		16, programmable filter	Type 2	TBX DES 16F22	0.510
	48 V	16	Type 2	TBX DES 1633	0.510
~	120 V	16	Type 2	TBX DES 16S04	0.510

Output base units (IP 20) (1)

Type of current	Output voltage	Modularity (no. of chan.)	Channel characteristics	Reference	Weight kg
transistor	24 V	16	0.5 A protected	TBX DSS 1622	0.580
			0.5 A protected wiring check	TBX DSS 16C22	0.580
~ ou --- relay	~ 24/240 V --- 24/48 V	12	100 VA not protected	TBX DSS 1235	0.610
	~ 24/240 V --- 24 V	16	50 VA not protected	TBX DSS 1625	0.610

I/O base units (IP 20) (1)

Type of current	Input voltage	Output voltage	Modularity (no. of chan.)	IEC 1131 2 conformity	Reference	Weight kg
transistor	--- 24 V	--- 24 V	8 I/O 0.5 A protected	Type 2	TBX DMS 16C22	0.530
			8 I/O 2 A protected	Type 2	TBX DMS 16C222	0.530
			Programmable from 16 I/O to 8 I/O 0.5 A protected	Type 2	TBX DMS 16P22	0.530
~ ou --- relay	--- 24 V	~ 24/240 V --- 24 V	8 I/O (2)	Type 2	TBX DMS 1025	0.540
			8 I/O (2)	Type 2	TBX DMS 1625	0.570
~ triac	~ 120 V	~ 120 V 50/60 Hz	8 I/O (3)	Type 2	TBX DMS 16S44	0.570

(1) Requires the TBX LEP 020/030 communication module to constitute a base, requires the TBX CBS 010 cover and cable unit to constitute an extension.
(2) 50 VA outputs, not protected.

Modicon Premium automation platform

TBX distributed discrete I/O modules



TBX LEP 020/030



TBX BLP 01



TBX SUP 10



TBX CBS 010



TBX GND 015



TBX RV 015

Fipio communication modules

Description	Connection	Reference	Weight kg
Communication modules for I/O base units	Fipio fieldbus on TBX discrete or analog IP 20 I/O base units	TBX LEP 030	0.280
	Fipio fieldbus on TBX discrete IP 20 I/O base units	TBX LEP 020	0.280
Connection terminal block	Tap link or daisy-chained on Fipio bus	TBX BLP 01	0.080

Process power supply unit

Description	Input voltage	Output current	Reference	Weight kg
~ 110/240 V 50/60 Hz or ~ 125 V	~ 24 V	1 A protected	TBX SUP 10	0.290

Accessories (1)

Description	Use	Sold in lots of	Unit Reference	Weight kg
Cover and connecting cable	For extension on TBX base units	1	TBX CBS 010	0.100
Earthing strip	For connecting cable shielding on TBX terminal block	5	TBX GND 015	0.060
Inter-terminal connection comb (9 terminals per comb)	Channel commons on TBX terminal block	5	TBX RV 015	0.020
8-channel simulator with/without line check function	8 inputs displayed	1	TBX SEP 08	0.120
	8 inputs displayed	1	TBX SSP 08	0.140

(1) For Fipio bus connection accessories, see pages 5/102 and 5/103.

Modicon Premium automation platform

TBX distributed discrete I/O modules

Monobloc I/O modules

TBX CEP 1622 input \approx 24 V

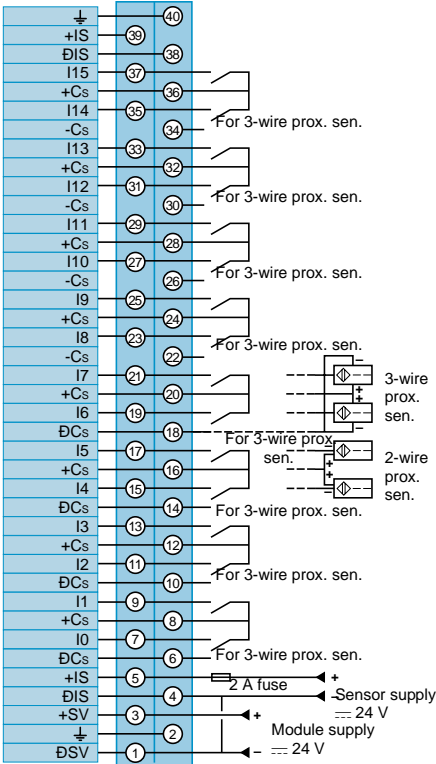

TBX CSP 1622 output \approx 24 V

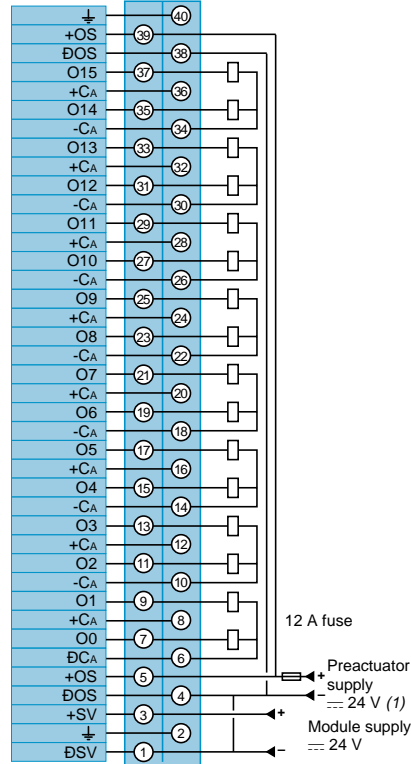

TBX CSP 1625 relay output

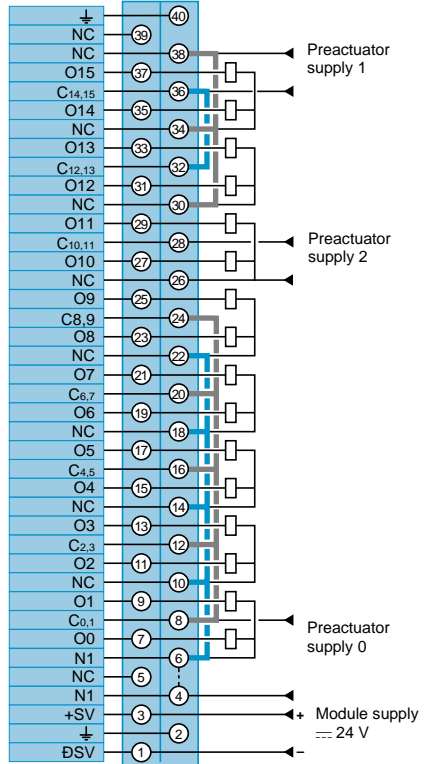

Input base units

TBX DES 1622/16C22/16F22 input \approx 24 V

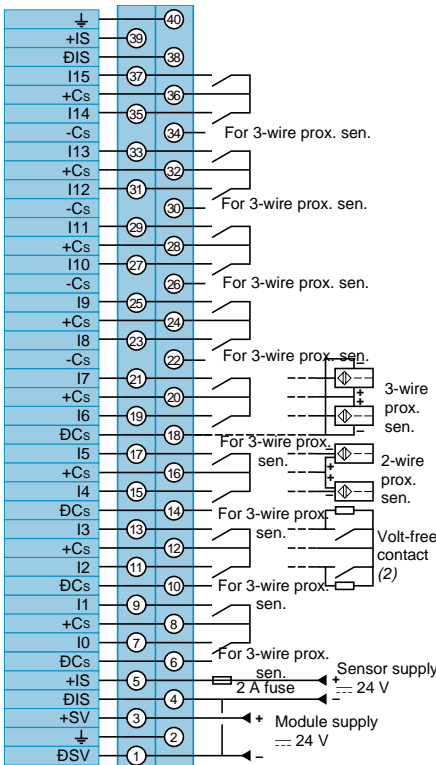

TBX DES 1633 input \approx 48 V

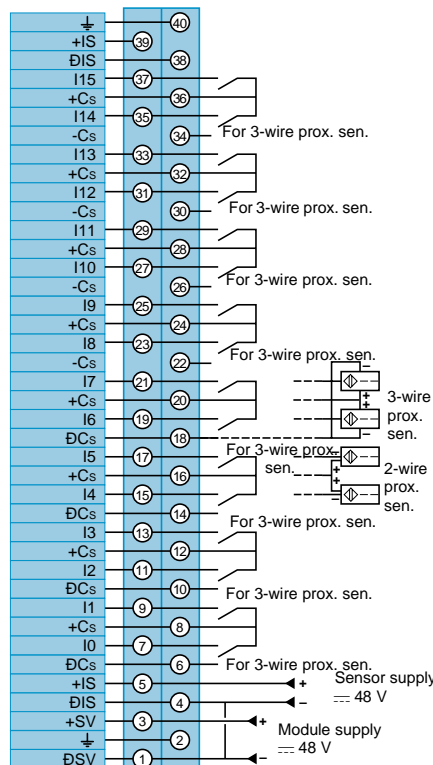

TBX DES 16S04 input \sim 120 V

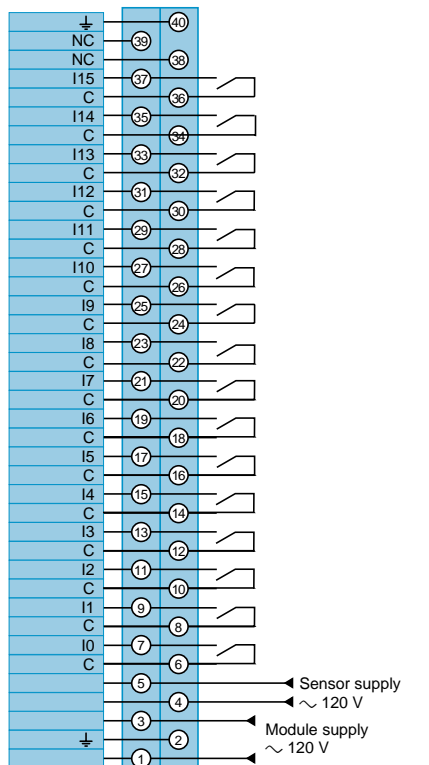

(1) Fast-blow fuse must be fitted to sensor supply.
 (2) With TBX DES 16C22.

Modicon Premium automation platform

TBX distributed discrete I/O modules

Output base units

TBX DSS 1622/16C22 output \approx 24 V

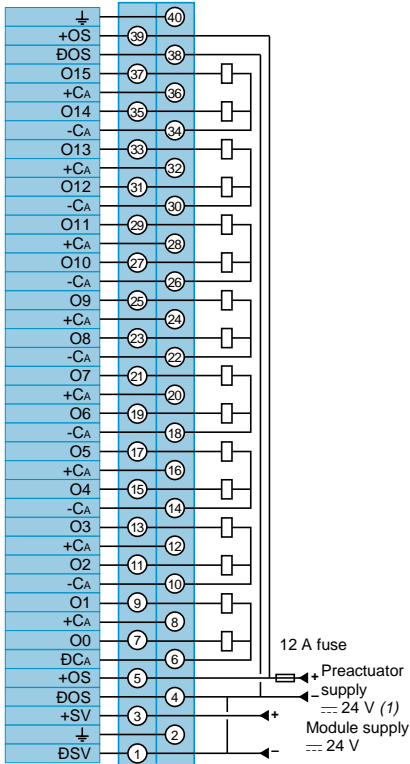

TBX DSS 1235 output relay

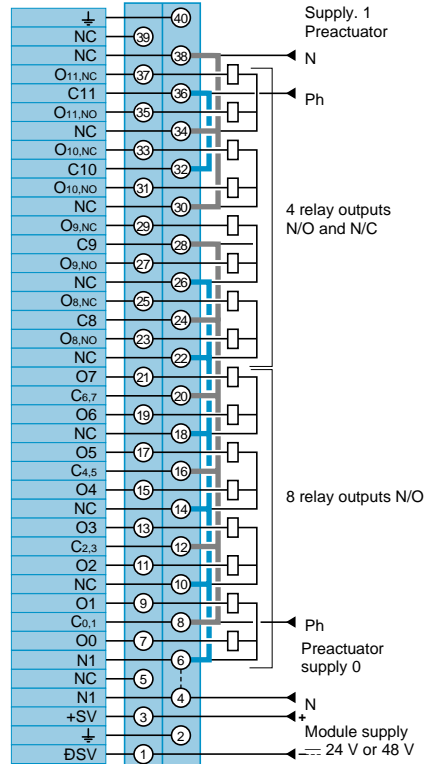

TBX DSS 1625 output relay

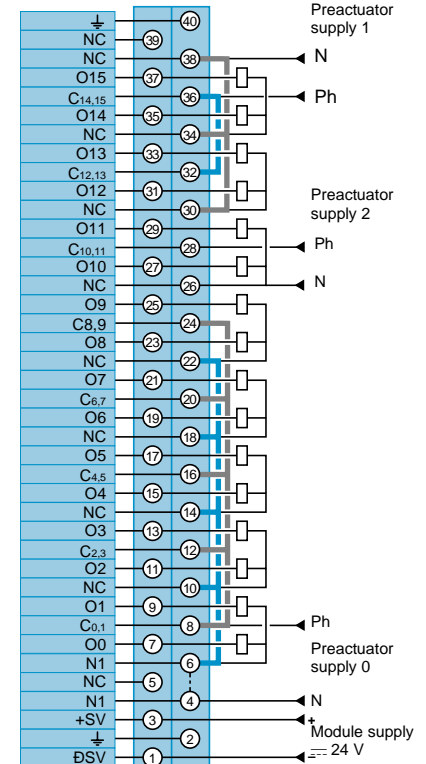

(1) Fast-blow fuse must be fitted to preactuator supply.

Dimensions

TBX CEP/CSP modules
TBX DES/DSS/DMS base units with
TBX LEP 020/030 or TBX CBS 010 module

TBX SUP 10 power supply unit

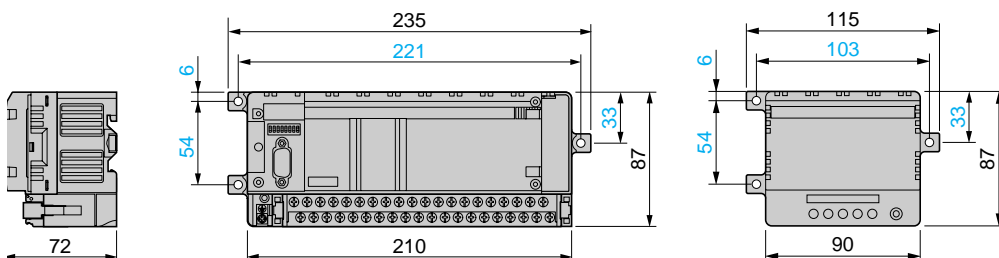

Mounting

TBX CEP/CSP/DES/DSS/DMS, TBX SUP 10
on AM1 PA/PB/PC perforated mounting plate

TBX CEP/CSP/DES/DSS/DMS, TBX SUP 10
on AM1 DP200 or AM1 DE200 rail

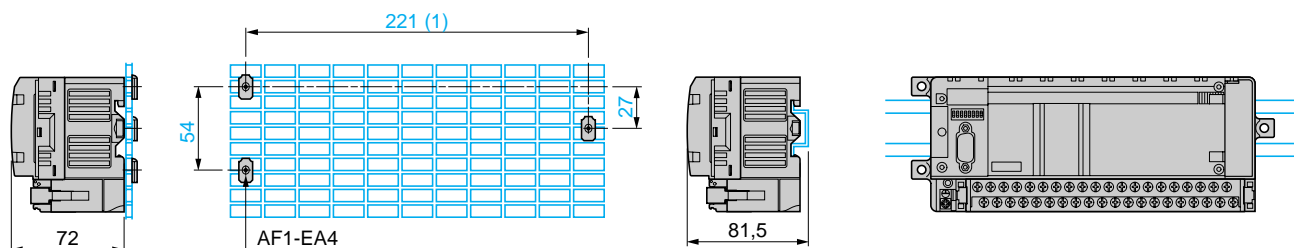

Fixed by 3 screws with captive washer M4 x 16 AF1-VA416

(1) 103 for TBX SUP 10 power supply

Nota : In order to ensure correct operation of TBX modules in severe electromagnetic conditions, the modules must be mounted on metal supports correctly connected to earth. The base module and the extension module must be installed on the same plate, or the same rail, or on rails connected to each other by a metal crossbar.

Mounting vertically

Mounting side by side

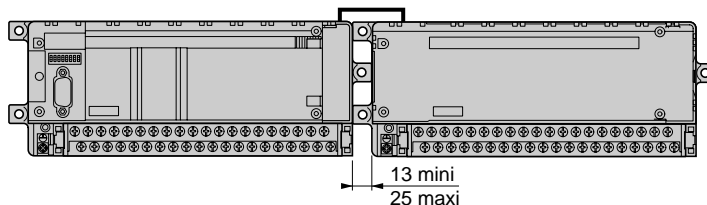
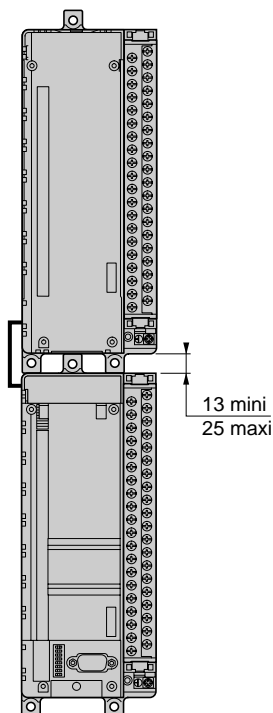

Mounting one above by other

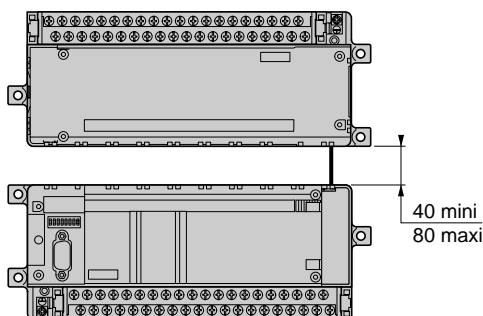

Modicon Premium automation platform

TBX distributed analog I/O modules

Applications

Distributed analog inputs on Fipio bus



3
3.1

Type of I/O

Type

Range

High level inputs		Temperature probe inputs	Thermocouple inputs
Voltage	Current	Pt 100, Pt 1000, Ni 1000	B, E, J, K, N, R, S, T
± 5 V ± 10 V	0...20 mA 4...20 mA	–	± 20 mV ± 50 mV ± 200 mV ± 500 mV

Modularity

4 channels

Isolation

- ~ 500 V ms between channels
- ~ 500 V ms between channels and earth
- ~ 1500 V ms between supply and channels
- ~ 1500 V ms between supply and earth

Acquisition period for the complete module

400 ms in 50 Hz mode (4 channels)
340 ms in 60 Hz mode (4 channels)

Resolution

12 bits + sign

Restitute time

Input filtering

1st order with user-definable time constant

Fallback position

Type of module

TBX AES 400

Pages

3/25

Distributed analog I/O on Fipio bus



Distributed analog outputs on Fipio bus



Voltage/current inputs

Voltage	Current
0...5 V ± 10 V	0...20 mA 4...20 mA

6 channels

No isolation between input channels

- ~ 1500 V ms between input channels and output channels
- ~ 1500 V ms between supply and channels
- ~ 1500 V ms between supply and earth

42.4 ms

12 bits (including sign)

Voltage/current outputs

Voltage	Current
± 10 V	4...20 mA 0...20 mA

2 channels

~ 1500 V ms between output channels

11 bits + sign

11 bits

4 ms

Voltage/current outputs

Voltage	Current
± 10 V	4...20 mA 0...20 mA

11 bits + sign

11 bits

At zero value on internal module fault
At the last value or at a value defined by the user
on Fipio communication fault

TBX AMS 620

TBX ASS 200

Modicon Premium automation platform

TBX distributed analog I/O modules

Decentralising the I/O meets the requirements of both users and machine manufacturers while maintaining performance comparable with that of a centralised structure.

Distributed analog I/O modules complete the TBX range of distributed I/O modules. They provide general discrete I/O module functions with the benefit of:

- Connection to the Fipio fieldbus.
- Wiring system.
- Size.

Distributed analog I/O base units offer a wide range of analog inputs for acquisition of high and low level measurements, both voltage and current.

Three modular base units are available:

- 4 multi-range inputs, TBX AES 400.
- 6 high level inputs (voltage/current), 2 outputs (voltage/current), TBX AMS 620.
- 2 outputs (voltage/current), TBX ASS 200.

A TBX LEP 030 communication module is required when 1 or 2 analog base units (base or extension) are connected at any Fipio fieldbus connection point. The number of analog channels for TBX base units of the same type is limited to 1008.

Description

Modular analog base units

Distributed analog I/O base units comprise:

- 1 32-way female 1/2 DIN connector for connecting to the TBX LEP 030 communication module.
- 2 Removable screw terminal block (with terminal label) for wiring the analog sensors and actuators.
- 3 Screw clamp for earthing the base unit.
- 4 Location for user's identification label.

Fipio communication module

The TBX LEP 030 communication module comprises:

- 1 9-way male SUB-D type connector for connecting to the Fipio fieldbus.
- 2 Five dip switches for setting the Fipio address together with an address coding label.
- 3 Location for the user's module/connection point identification label.
- 4 I/O display window.
- 5 Access cover for 32-way female 1/2 DIN connector for connecting the Extension base unit.

Cover and cable for extension modules

The TBX CBS 010 cover and cable unit comprises:

- 1 Flexible connecting cable with two 32-way male 1/2 DIN moulded connectors for connecting the base unit to the TBX LEP 030 communication module.
- 2 Cover to be fixed to the discrete or analog I/O base unit.
- 3 Location for the user's module/connection point identification label.

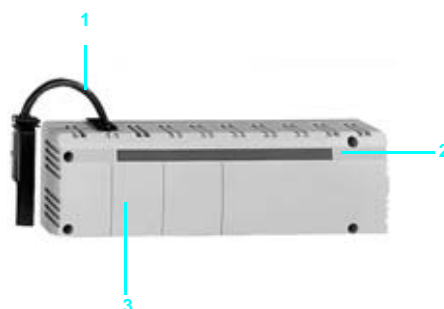
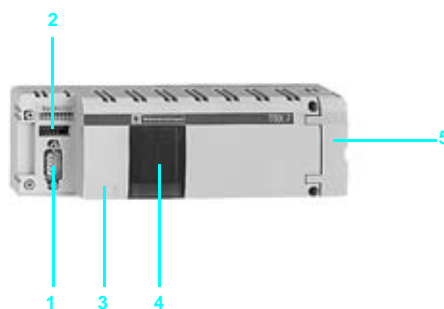
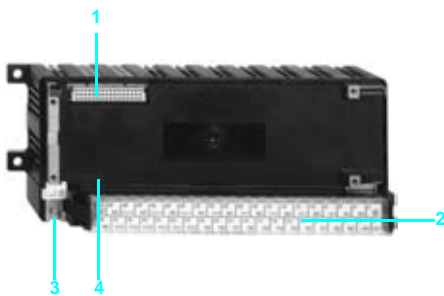

Modicon Premium automation platform

TBX distributed analog I/O modules

Modular TBX base unit combinations

Analog base units require a TBX LEP 030 communication module for connecting the connection point to the Fipio fieldbus.

As they are modular in structure, discrete and analog base units can be used in the following combinations:

Mix of modules (1)	Base		Extension	
	Communicator	Base unit	Base unit	Cover
	TBX LEP 030	TBX A●S ●●●	–	–
	TBX LEP 030	TBX A●S ●●● (1)	TBX D●S ●●● (1)	TBX CBS 010
	TBX LEP 030	TBX A●S ●●●	TBX A●S ●●●	TBX CBS 010
	TBX LEP 030	TBX D●S ●●● (1)	TBX A●S ●●● (1)	TBX CBS 010

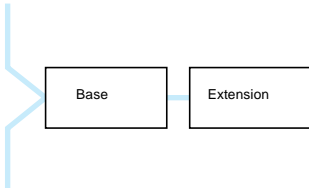

(1) In the case of the Premium automation platform, the combinations of base units and extensions on any one Fipio connection point must be of the same type (it is not possible to mix discrete I/O and analog I/O).

Functions

TBX AES 400 analog modules, with 4 high level (voltage or current) or low level (temperature probe or thermocouple) isolated inputs, TBX AMS 620, with 6 high level isolated inputs (voltage or current) / 2 isolated outputs (voltage or current), and TBX ASS 200, with 2 isolated outputs (voltage or current) offer the following functions:

Input channels

- Measurement acquisition
 - selection of the input range for each channel and first order filtering with user-configurable time constant.
- Processing
 - automatic linearization (TBX AES 400),
 - integral cold junction compensation for thermocouples (TBX AES 400).
- Operation
 - conversion of measurements into standard units or temperatures whose parameters can be defined by the user.
- Checks
 - recalibration and self-calibration of each channel in relation to an internal reference (TBX AMS 620),
 - checking input value overruns ($\pm 5\%$ of the selected range),
 - checking the sensor link.

Output channels

- Output range selection
 - voltage or current for each module channel.
- Output fallback

On a communication fault with the PLC, the user can select:

 - fallback of the output to a defined value,
 - to maintain the output at its previous value,
 - On an internal module fault, all the outputs on the same module fall back to zero.
- Output protection

Output modules are protected against:

 - open circuit overloads,
 - short-circuits.

All these parameters are selected during software configuration.

3

3.1

Type of base unit			TBX AES 400	TBX AMS 620	TBX ASS 200
Analog input modularity			4 channels	6 channels	–
Input ranges		mV	± 20	–	–
		mV	± 50	–	–
		mV	± 200	–	–
		mV	± 500	–	–
		V	± 5	0...5	–
		V	± 10	–	–
		mA	0...20	–	–
		mA	4...20	–	–
	Temperature probes		Pt 100, Pt 1000, Ni 1000	–	–
	Thermocouples		B, E, J, K, N, R, S, T	–	–
Special characteristics					
	Self-calibration		No	Yes	–
	Automatic linearization		Yes	Yes	–
Resolution			12 bits + sign	12 bits	–
Acquisition period	For entire module		ms	For 4 channels: 400 (50 Hz mode) 340 (60 Hz mode)	For 6 channels: 42.4
Rejection (50 Hz)	Serial mode		dB	50	–
	Common mode		dB	> 130 for ± 20 mV	–
			dB	> 90 for ± 10 V	–
Maximum error at 25 °C/60 °C	± 10 V	% FS	0.23/0.99	0.20/0.29	–
	0...5 V	% FS	0.23/0.99	0.15/0.22	–
	0...20 mA	% FS	0.23/0.99	0.25/0.43	–
	4...20 mA	% FS	0.23/0.99	0.25/0.43	–
	Low level	% FS	0.90/1.69 (1)	–	–
External resistors (supplied with TBX AES 400 module)	Use as 4...20 or 0...20 mA		Ω	250 at 0.1% parallel on the input	–
Permitted overload	Voltage	V	± 30	± 30	± 30
	Current	mA	± 25	± 30	± 30
Isolation (2)	Between input channels		V rms	500	Non-isolated
	Between output channels		V rms	–	1500
	Between channels and earth		V rms	500	1500
	Between channels and supply		V rms	1500	1500
	Between supply and earth		V rms	1500	–
Common mode voltage (2) permitted during operation between channel and earth and between channels			V	± ± 100	–
			V rms	75	150
Temperature	Operation		°C	0...55	–
	Storage		°C	- 25...+ 70	–

Type of base unit			TBX AES 400	TBX AMS 620	TBX ASS 200
Analog output modularity			–	2 channels	–
Output ranges	Voltage	V	–	± 10	–
	Current	mA	–	4...20, 0...20	–
Resolution	Voltage		–	11 bits + sign	–
	Current		–	11 bits	–
Refresh period	Per channel	ms	–	5	–
Load impedance	Voltage	Ω	–	≥ 1000	–
	Current	Ω	–	≤ 600	–
Leakage current	Current	μA	–	50 (0...20 mA)	–
Maximum error at 25 °C/60 °C	Voltage	% FS	–	0.45/0.75	–
	Current	% FS	–	0.52/0.98	–

(1) Accuracy at low level covers the whole ± 20 mV, ± 50 mV range, the middle of the range for Pt 100, Pt 1000 and Ni 1000, with any orientation, and the middle of the range for B, E, J, K, N, R, S and T thermocouples.
 (2) Voltage in volts rms 50/60 Hz for 1 minute.

References



TBX AES 400

Analog base units (1)

Type of input/output	Number of channels	Ranges	Reference	Weight kg
Input 12 bits + sign	4 channels (2)	$\pm 5\text{ V}$, $\pm 10\text{ V}$, $\pm 20\text{ mV}$, $\pm 50\text{ mV}$, $\pm 200\text{ mV}$ 0...20 mA, 4...20 mA, Low level $\pm 500\text{ mV}$ Thermocouples B, E, J, K, N, R, S, T Temp.probes Pt 100, Pt 1000, Ni 1000	TBX AES 400	0.280
Isolated output 11 bits	2 channels	$\pm 10\text{ V}$, 0...20 mA, 4...20 mA	TBX ASS 200	0.280
High level input 12 bits isolated output 11 bits	6 channels 2 channels	$\pm 10\text{ V}$, 0...5 V, 0...20 mA, 4...20 mA $\pm 10\text{ V}$, 0...20 mA, 4...20 mA	TBX AMS 620	0.280

Communication module and accessories

Description	Connection	Reference	Weight kg
Fipio communication module	Fipio fieldbus on TBX base units	TBX LEP 030	0.280
Cable connector	Tap link or daisy chain to Fipio fieldbus	TBX BLP 01	0.080



TBX LEP 030

Replacement part

Set of 4 resistors 250 Ω $\pm 0.1\%$	Adaptation for TBX AES 400 current range	TSX AAK2	0.100
---	--	-----------------	-------

(1) Requires TBX LEP 030 communication module to constitute a base unit, requires TBX CBS 010 cover and cable unit to constitute an extension.

(2) Set of 4 resistors TSX AAK2 for adaptation to current range supplied.

Connections, dimensions (1)

TBX AES 400 input

TBX AMS 620 input/output (3)

TBX ASS 200 output

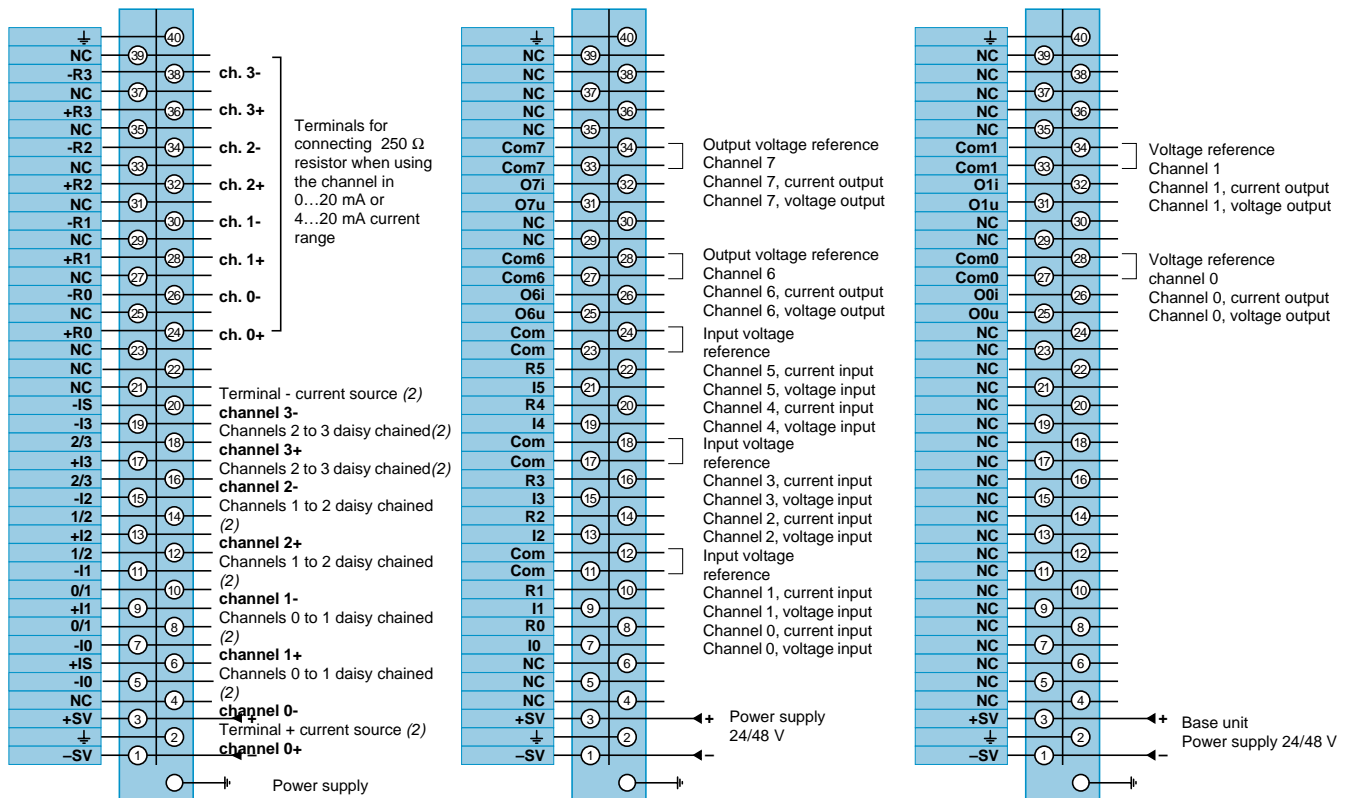

(1) Dimensions the same as for TBX discrete I/O module: see page 3/19.

(2) Inputs to be used for wiring temperature probes.

(3) To use an input channel as a current input, link terminals I_i and R_i of the corresponding channel.

Modicon Premium automation platform

IP 65/67 splitter boxes and modules

3

3.2

Splitter box and module type	Passive splitter boxes	Monobloc I/O splitter boxes and modules	
	Telefast, ABE9 splitter boxes	Advantys, FTB splitter boxes	TBX, I/O modules



Fielbus type	–	CANopen DeviceNet Profibus DP INTERBUS	Fipio
Number of inputs/outputs	8 I/O, 16 I/O	16 I, 8 I + 8 O, 12 I + 4 O, 16 I/O, 8 I + 8 I/O	8 I, 16 I, 8 O and 16 O
Type of signal	≡ 24 V digital		
Functions	Connection of 1 to 16 sensors/actuators		
Type of input/output connectors	M12		
Degree of protection	IP 67		IP 65
Housing type	Plastic	Plastic and metal	Zamac
Module type	ABE 9	FTB 1	TBX EEP/ESP
Pages	Consult our catalogue “IP 67 splitter boxes”		3/30

			Modular I/O splitter boxes
TSX E●F, I/O modules	170 ED●, I/O modules	Modules on AS-Interface cabling system	Advantys, FTM splitter boxes

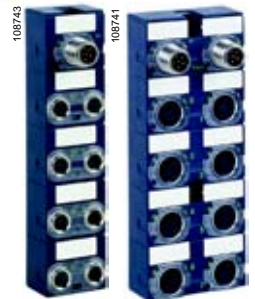
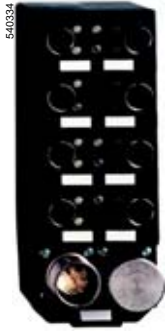

3

3.2

Fipio	INTERBUS	AS-Interface			CANopen DeviceNet Profibus DP
8 I, 16 I, 8 I/O and 8 O	16 I or 16 O	4 I or 2 I 4 O or 2 O	4 I	4 I or 2 I 4 O or 2 O	8 I, 16 I, 8 I/O and 16 I/O discrete 4 I or 4 O analogues
					≡ 24 V discrete and analogue
					Connection of 1 to 8 sensors/actuators
					Connection of 1 to 256 sensors/actuators per bus module
					M8 M12 M8
					M8 and M12
IP 67	IP 65	IP 67			
Plastic	Metal	Plastic			
TSX E●F	170 EDI/EDO	ASI ME● + ASI B●	ASI MMO●	XZ S●A	FTM 1▲
42315/10	48243/5	Consult our catalogue "AS-Interface cabling system"			Consult our catalogue "IP 67 splitter boxes" ▲ Available 1 st half 2004

General

Decentralising the I/O meets the requirement of both users and machine manufacturers while maintaining performance comparable with that of a centralised structure.

In the same way as distributed I/O modules, TBX dust and damp proof modules are used to create distributed control systems, which offer increased availability of installations. They also offer the possibility of locating the I/O interfaces close to the process or machines, in harsh environments (water jets, dust, etc).

TBX modules are addressed by the application program as "In rack" I/O, with which they can coexist.

TBX dust and damp proof distributed I/O modules are connected to Premium processors via the Fipio fieldbus (maximum number of modules per Fipio bus, see page 5/92).

TBX dust and damp proof I/O modules offer:

- Compact interface elements.
- Easy setup and connection:
 - sensors and actuators are directly connected to dust and damp proof standard connectors,
 - tools are available for local testing and diagnostics of both the interfaces and those devices which are connected to them.

TBX dust and damp proof I/O modules with IP 65 protection conform to the following test standards:

- UL, NEMA,
- CSA,
- IEC 65A,
- NFC 63850,
- to the CNOMO EO3 40 50 recommendation,
- to the NF 46 604 FIP standard.

Functions

TBX dust and damp proof distributed discrete I/O modules offer identical functions to those of the modular TBX I/O modules:

Reference	TBX EEP 08C22	TBX EEP 1622	TBX ESP 08C22	TBX ESP 1622
Wiring check				
Outputs fallback				
Assignment of I/O channels to application tasks				

■ Function available

TBX EEP 08C22/1622 dust and damp proof distributed input modules

The TBX EEP 08C22 input module (8 channels --- 24 V) and the TBX EEP 1622 input module (16 channels --- 24 V) have the following functions:

- Wiring check providing line check via short-circuit, open circuit or earth line detection.
- Assignment of each group of 8 input channels (channels 0 to 7 or 8 to 15) to a specific application task (fast, master or auxiliary task).

TBX ESP 08C22/1622 dust and damp proof distributed output modules

The TBX ESP 08C22 output module (8 channels --- 24 V) and the TBX EEP 1622 output module (16 channels --- 24 V) have the following functions:

- Transistor output protection, detection of overloads or short-circuits which can be used by the user program (channel by channel or for all 8 or 16 module channels).
- Reactivation of transistor outputs, choice of automatic reactivation or by user program.
- Wiring check providing line check via short-circuit, open circuit or earth line detection.
- Output fallback state: on module fault, maintains the state of the outputs at their last value or at a configured value (state 0 or 1) channel by channel.
- Assignment of each group of 8 output channels (channels 0 to 7 or 8 to 15) to a specific application task (fast, master or auxiliary task).

Modicon Premium automation platform

TBX discrete I/O IP 65 modules on Fipio bus



Description

TBX EEP/ESP 08C22 modules

Dust and damp proof distributed I/O modules are monobloc type in an IP 65 casing and comprise:

- 1 8 female M12 type fast connectors for connecting the sensors or preactuators.
- 2 8 channel status indicator lamps.
- 3 4 status indicator lamps for module operation and integrated communication.
- 4 A dust and damp proof connector for connection to the Fipio bus, and to the --- 24 V power supply.
- 5 For output modules, a --- 24 V preactuator power supply connector.

Connector to be ordered separately:

- TBX BLP 10 dust and damp proof connector which can also be used for coding connection points.
- For output modules, a TBX BAS 10 dust and damp proof power supply connector.

TBX EEP/ESP 1622 modules

Dust and damp proof distributed I/O modules are monobloc type in an IP 65 casing and comprise:

- 1 8 female M12 type fast connectors for connecting the sensors or preactuators (1 connector for 2 channels).
- 2 16 channel status indicator lamps (yellow lamps for even channels and green lamps for odd channels).
- 3 4 status indicator lamps for module operation and integrated communication.
- 4 A dust and damp proof connector for connection to the Fipio bus, and to the --- 24 V power supply.

For output modules, a --- 24 V preactuator power supply connector on the left side.

Connector to be ordered separately:

- TBX BLP 10 dust and damp proof connector which can also be used for coding connection points.
- For output modules, a TBX BAS 10 dust and damp proof power supply connector.



Connection principles

TBX dust and damp proof distributed I/O modules require a $\sim 24\text{ V}$ power supply. This supply can be provided:

- Via a TBX FP ACC 10 dust and damp proof network junction box **1**. In this case, the TSX FP CF●00 tap link cable **2** is required which is a screened twisted pair 150 W with 2 conductors carrying the $\sim 24\text{ V}$ supply for the modules. The mechanical and chemical resistance characteristics for this cable are suitable for use in harsh environments.

Directly to the TBX BLP 10 connector on the dust and damp proof TBX module **5**. In this case, a tap link off the trunk cable is made using the TSX FP ACC 4 T-junction box **3** with the TSX FP CC●00 tap link cable **4** (double twisted pair 150 Ω).

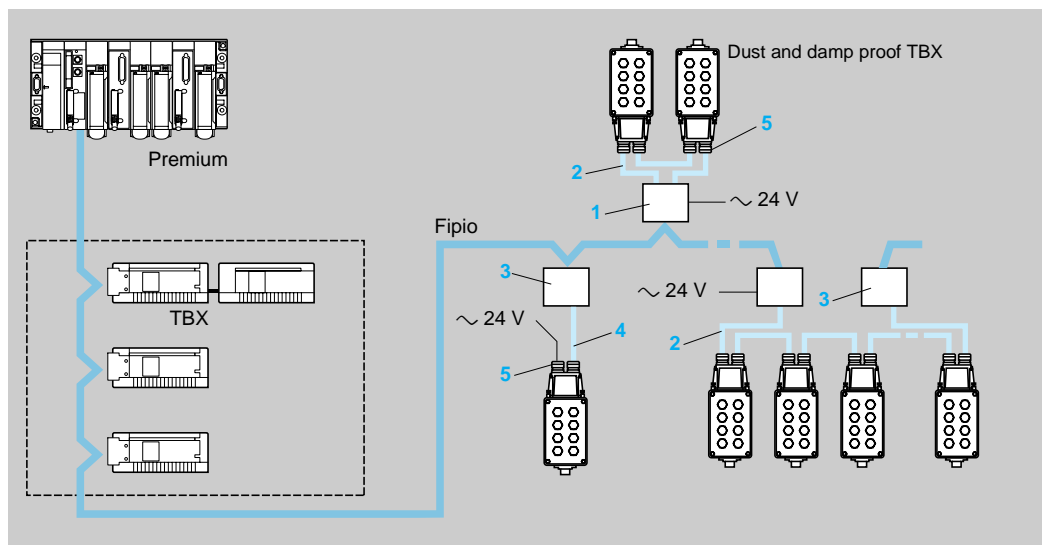

Daisy chaining dust and damp proof distributed I/O modules using a TBX FP ACC 10 T-junction box

Using a TBX FP ACC 10 junction box **1** up to 10 TBX dust and damp proof modules can be daisy chained.

Since power is carried to the TBX dust and damp proof I/O modules via the TSX FP CF●00 tap link cable **2**, the length of the tap links depends on the type of $\sim 24\text{ V}$ power supply and the number of TBX dust and damp proof modules daisy chained on the same tap link. The lengths in metres are given in the table below:

Number of TBX dust and damp proof modules in daisy chain	1	2	3	4	5	6	7	8	9	10
$\sim 24\text{ V} \pm 3\%$ supply	263	131	87	65	51	42	36	31	27	24
$\sim 24\text{ V} \pm 5\%$ supply (1)	232	116	77	57	45	37	31	27	24	21
$\sim 24\text{ V} \pm 10\%$ supply	154	77	51	38	30	24	20	17	15	13

(1) For TBX SUP 10 power supply unit.

Type of inputs module			TBX EEP 08C22	TBX EEP 1622	
Modularity			8	16	
Nominal input values	Voltage	V	≐ 24		
	Current	mA	7		
	Sensor supply (ripple included)	V	≐ 19.2...30		
Input limit values	At state 1	Voltage	V	≥ 11	
		Current	mA	≥ 6 for 11 V	
	At state 0	Voltage	V	< 5	
		Current	mA	≤ 2	≤ 1.4
Input impedance			kΩ	3.4	
Logic			Positive		
Response time	Change from 0 at 1	ms	6	5...11	
	Change from 1 at 0	ms	6	5...13	
Protection against polarity inversion	Sensor supply		Reverse mounted parallel diode	Series diode	
Dissipated power	Per module (with 60 % load)	W	2.6	2.7...24 V	
Typical currents consumed	Module supply	mA	40	95 (at 24 V)	
	Sensor supply	mA	70	100 (at 24 V)	
Type of inputs			Current sink, conforming to IEC 1131 type 2		
Sensor common			To "+ve" of supply		
Compatibility output modules			TBX transistor outputs of the same voltage		
External line	Line resistance	Ω	< 500 with volt-free contact, < 100 with 2-wire proximity sensor		
	Open line leakage resistance	kΩ	> 30 with volt-free contact, > 100 with 2-wire proximity sensor		
Isolation	Dielectric strength between inputs and earth	V eff	1500 at 50/60 Hz for 1 min		
	Insulation resistance	MΩ	> 10 at ≐ 500 V		
Temperature	Operation	°C	5...60		
	Storage	°C	- 25...+ 70		

Type of outputs module			TBX ESP 08C22	TBX ESP 1622
Modularity			8	16
Loads	Voltage	V	≐ 24	
	Nominal current	A	0.5	
	Tungsten filament lamp	W	8	
Limit values	Voltage (ripple included)	V	≐ 19.2...30	
Logic			Positive outgoing current	
Response time	Change from state 0 to 1	ms	≤ 1	
	Change from state 1 to 0	ms	≤ 1	
Leakage current	At state 0	mA	< 2	
Residual voltage	At state 1	V	< 0.4	
Built-in protection	Against overloads		Yes (thermal)	
	Against overvoltages		Zener Diode	
	Against inverse polarity		Reverse mounted parallel diode	Series diode
Load common			To "-ve" of supply	
Typical currents consumed	Module supply	mA	30	107 (at 24 V)
	Preactuator supply	mA	45 (except actives outputs)	51 (at 24 V)
Dissipated power	Per module (with 60 %load)	W	4.3	3.7 (at 24 V)
Compatible input modules			Yes	
Load impedance	At state 1	Ω	50 < Z < 3000	
Isolation	Dielectric strength between inputs and earth	V eff	1500 at 50/60 Hz for 1 min	
	Insulation resistance	MΩ	> 10 at ≐ 500 V	
Temperature	Operation	°C	0...60	
	Storage	°C	- 25...+ 70	

Modicon Premium automation platform

TBX discrete I/O IP 65 modules on Fipio bus



TBX EEP 08C22



TBX ESP 1622



TSX FP ACC 4



TBX BLP 10



TBX BAS 10

Dust and damp proof monobloc discrete I/O modules

Type of module	Operating voltage	Modularity (no. of channels)	Characteristics	Reference	Weight kg
Input	= 24 V	8	Conforming to IEC 1131 type 2 Wiring check function	TBX EEP 08C22	0.510
		16	Conforming to IEC 1131 type 2	TBX EEP 1622	0.510
Output	= 24 V	8	0.5 A protected Wiring check function	TBX ESP 08C22	0.580
		16	0.5 A protected	TBX ESP 1622	0.580

Accessories (1)

Type of module	Characteristics	Reference	Weight kg
Dust and damp proof junction box	Tap link off trunk cable Holds 1 female 9-way SUB-D connector Zamac casing	TSX FP ACC 4	0.660
	Tap link off trunk cable including wires for = 24 V supply. Holds 1 female 9-way SUB-D connector Zamac casing	TBX FP ACC 10	0.680
Dust and damp proof connector for TBX modules	Tap link or daisy chaining with adress coding	TBX BLP 10	0.320
Dust and damp proof supply connector for TBX output modules	= 24 V preactuator power supply for TBX ESP 08C22/1622 output modules	TBX BAS 10	0.120

(1) For other Fipio accessories and connection cables, see pages 5/102 et 5/103.

Connections

TBX EEP 08C22 inputs

Mechanical contacts

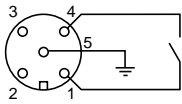

2-wire prox.sen.

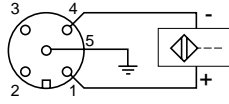

3-wire prox.sen.

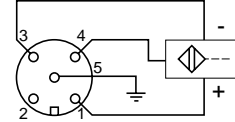

TBX EEP 1622 inputs

Mechanical contacts

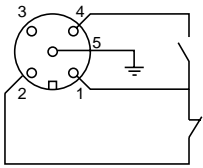

2-wire prox.sen.

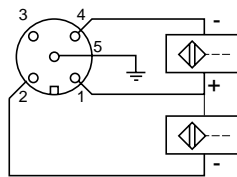

3-wire prox.sen.

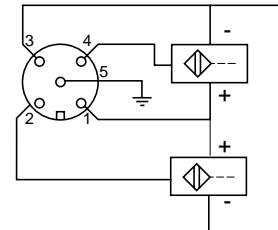

TBX ESP 08C22 outputs

Direct wiring

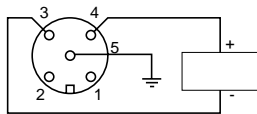

Wiring with amplification

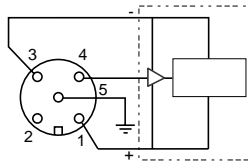

Outputs TBX ESP 1622

Direct wiring

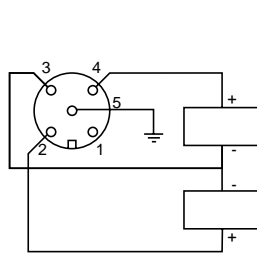

Wiring with amplification

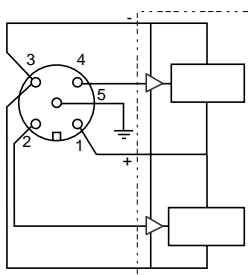

Preactuator supply via
TBX BAS 10 connector

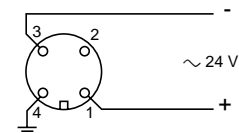

Dimensions, mounting

TBX EeP ●●22 inputs/outputs

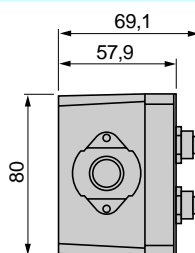
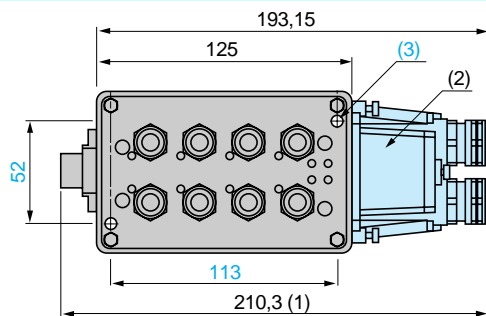

(1) For TBX ESP 08C22/1622

(2) TBX BLP 10 connector

(3) 2 holes \varnothing 4.4

Modicon Premium automation platform

Discrete I/O IP 67 modules on Fipio bus

Presentation

Decentralising the I/O meets the requirements of both users and machine manufacturers while maintaining performance comparable with that of a centralised structure.

Fipio bus dust and damp proof I/O modules are used to create distributed control systems by removing the need for enclosures, improving connections and thus increasing the availability of installations. These IP 67 protection modules also offer the possibility of locating the standard I/O interfaces used in the processes or machines in harsh environments (oil jets, water jets, dust etc).

PL7 Junior/Pro programming software is used for the software configuration and installation of the dust and damp proof I/O modules on the Fipio bus.

There are 4 types of Fipio bus dust and damp proof I/O module:

- Input module, 8 channels, \sim 24 V IEC type 2: TSX EEF 08D2.
- Input module, 16 channels \sim 24 V IEC type 2: TSX EEF 16D2.
- Mixed module, 8 IEC type 2 inputs/8 x 0.5 A transistor outputs, \sim 24 V: TSX EMF 16DT2.
- Output module, 8 channels, 2 A transistor outputs, \sim 24 V: TSX ESF 08T22.

Furthermore, this new module design offers a number of special functions:

- Remote power supply: the Fipio modules, inputs, and Fipio communication power supplies are provided using a single cable. Each remote power supply can be used to power up to 31 modules.
- A daisy-chained module can be changed without interrupting the bus.
- An operator terminal can be connected at any point on the bus.
- Short-circuits in the sensor power supply can occur without causing the bus to malfunction.
- A Fipio bus fast connection system using cables and M23 connectors.
- A sensor/preactuator fast connection system using an M12 connector.

The Fipio bus dust and damp proof I/O modules conform to the following standards and approvals:

- IEC 1131.
- CNOMO.
- Fipio certification.
- DIN.
- UL certification.
- CSA certification.
- C€ mark.

Architecture

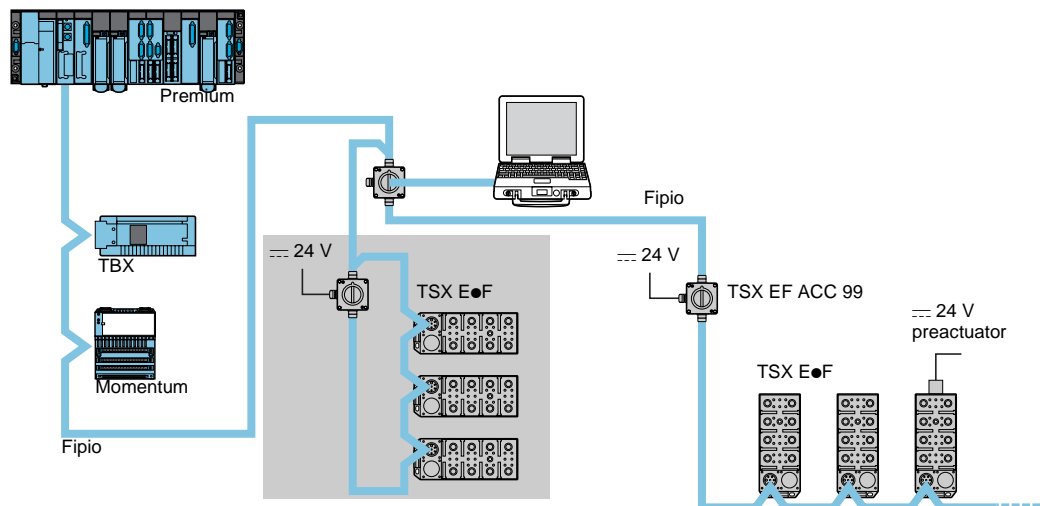

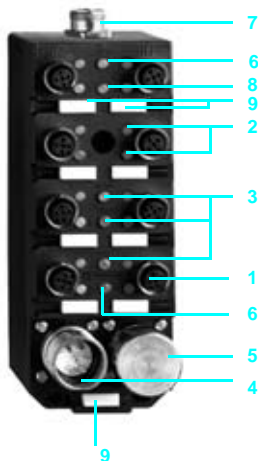
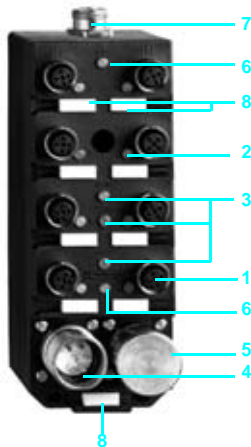
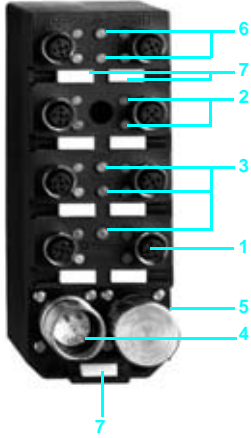

Architecture (continued)

The Fipio fieldbus is a standard relating to communication between different automation components where the IP 67 dust and damp proof I/O are located remotely.

Each segment supports up to 31 IP 67 I/O modules over a maximum distance of 1000 meters. Because the IP 67 I/O modules have a remote power supply, the voltage drops caused by the connected modules limit the maximum distances between each T-junction box (from the one which provides the \approx 24 V power supply) and the remote powered IP 67 I/O modules. For the calculation of these distances, see page 3/40.

The use of electrical or electrical/fiber optic repeaters allows the connection of up to 98 IP 67 I/O modules on 5 segments over a maximum distance of 15,000 meters.

Description

TSX EEF 08D2 and TSX EEF 16D2 modules

Dust and damp proof input modules are monobloc type in an IP 67 casing and comprise:

- 1 8 female M12 type fast connectors for connecting the sensors (2 input channels per connector for the 16-channel model).
- 2 8 or 16 channel status indicator lamps.
- 3 3 status indicator lamps for module operation and integrated communication.
- 4 Dust and damp proof male M23 type connector for connection of the Fipio bus, the \approx 24 V power supply for the sensor and the internal electronics of the module.
- 5 Access to the addressing micro-switch.
- 6 1 or 2 sensor power supply fault indicators.
- 7 9 slots for channel and module referencing labels (10 labels supplied).

Two sealing plugs for M12 connectors are supplied with every module.

TSX ESF 08T22 module

Dust and damp proof output modules are monobloc type in an IP 67 casing and comprise:

- 1 8 female M12 type fast connectors for connecting the preactuators.
- 2 8 channel status indicator lamps.
- 3 3 status indicator lamps for module operation and integrated communication.
- 4 Dust and damp proof male M23 type connector for connection of the Fipio bus and the power supply for the internal electronics of the module.
- 5 Access to the addressing micro-switch.
- 6 2 preactuator power supply presence indicators.
- 7 A male 7/8" type connector for connecting the two \approx 24 V preactuator power supplies.
- 8 9 slots for channel and module referencing labels (10 labels supplied).

Two sealing plugs for M12 connectors are supplied with the module.

TSX EMF 16DT2 module

Dust and damp proof I/O modules are monobloc type in an IP 67 casing and comprise:

- 1 8 female M12 type fast connectors of which 4 are for connecting the sensors and 4 for the preactuators (2 input channels or 2 output channels per connector).
- 2 16 channel status indicator lamps.
- 3 3 status indicator lamps for module operation and integrated communication.
- 4 Dust and damp proof male M23 type connector for connection of the Fipio bus, the \approx 24 V power supply for the sensor and the internal electronics of the module.
- 5 Access to the addressing micro-switch.
- 6 2 preactuator power supply presence indicators.
- 7 A male 7/8" type connector for connecting the two \approx 24 V preactuator power supplies.
- 8 1 sensor power supply fault indicator.
- 9 9 slots for channel and module referencing labels (10 labels supplied).

Two sealing plugs for M12 connectors are supplied with the module.

Modicon Premium automation platform

Discrete I/O IP 67 modules on Fipio bus

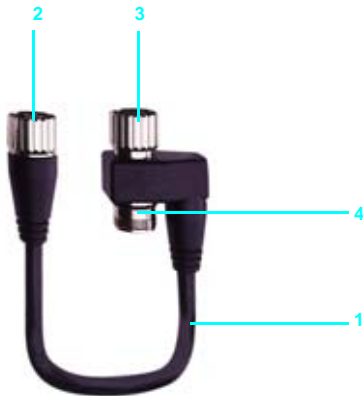

TSX EF ACC 2 Fipio bus connecting cables

TSX EF ACC 2 cables are used to carry Fipio bus signals and the 24 V power supply for the sensors and the internal electronics of TSX EEF/ESF/EMF modules.

They comprise:

- 1 A trunk cable, with a 150 Ω shielded twisted pair and a 1.5 mm² power supply pair, 0.2, 1, 3, 7, 12 or 25 m long depending on the model (radius of curvature 30 mm, Ø 9.5 mm).

At one end:

- 2 An insulated IP 67 male connector, with M23 type ring, 6-way for Fipio connection to the preceding module n-1 (or to the upstream T-junction box).

At the other end: an insulated double connector comprising :

- 3 An IP 67 female connector, with M23 type ring, 6-way for connection to module n.
- 4 An IP 67 female connector, with M23 type thread, 6-way for an outgoing cable of the same type for connection to the next module n+1 (or to the downstream T-junction box).

Use of this cable on the dust and damp proof I/O modules:

- Locks access to the module's Fipio addressing microswitch.
- Ensures continuity of the Fipio bus even if the module is disconnected (when replacing a module, for example). Patented system.

TSX EF ACC 99 T-junction box

The IP 65 T-junction box comprises:

- 1 A male M23 type soldering connector for connecting the Fipio bus (incoming and outgoing).
- 2 A male 7/8" type connector for connecting the 24 V power supply for the remote powered modules, fitted with a protective plug.
- 3 A female M23 type connector for connecting the Fipio bus (outgoing), fitted with a sealing plug.
- 4 An access cover for the 9-way female SUB-D connector used for connecting an operator terminal.

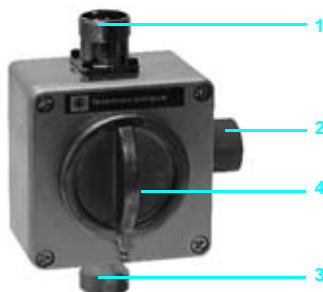

Functions

Remote dust and damp proof I/O modules integrate the following monitoring devices :

■ Inputs:

- power supply fault monitoring in groups of 8 channels. Indicated on the front panel by the SF1 and SF2 indicator lamps (red).
- module fault monitoring. Indicated on the front panel by the ERR indicator lamp (red).

One fault bit for the whole module is available at PLC processor level for use by the user program.

■ Outputs:

- preactuator power supply presence monitoring in groups of 4 channels. Indicated on the front panel by the US1 and US2 indicator lamps (green). A power supply presence bit is associated with each indicator lamp.
- short-circuit monitoring for each channel. Indicated on the front panel by an indicator lamp for each channel (red). There is one fault bit per channel (for 8 channel modules) or per group of 2 channels (for mixed modules). In addition, there is one bit per group of 4 channels which can be used to reset the channels remotely.
- module fault monitoring. Indicated on the front panel by the ERR indicator lamp (red). One fault bit for the whole module is also available.

In the case of the TSX EMF 16DT2 mixed module, a diagnostic bit allows the origin of the power supply fault to be determined (input or output power supply).

Environmental characteristics

Type of module		TSX EEF 08D2/EEF 16D2/ESF 08T22/EMF 16DT2	TSX ACC 99
Temperature	Operation	°C	0...60
	Storage	°C	0...60
Degree of protection		IP 67	IP 65
Altitude	m	0...2000	
Vibration resistance		Testing in progress	
Protection against shocks		15 gn/11 ms	
Operating positions		All positions	

Input characteristics

Type of module		TSX EEF 08D2	TSX EEF 16D2	TSX EMF 16DT2
Inputs channels	Number	8 inputs	16 inputs	8 inputs (8 outputs, see page 3/38)
	Groups of channels	1	2	1
Conforms to IEC 1131 2		Yes, type 2		
Proximity sensor compatibility	2-wire/3-wire	Yes		
Nominal values	Voltage	V	≐ 24 (positive logic)	
	Current	mA	7	
	Sensor power supply (ripple included)	V	≐ 19.2...30	
Inputs limit values	Voltage	At state 0	V	≤ 5
		At state 1	V	≥ 11
	Current	At state 0	mA	≤ 2
		At state 1	mA	≥ 6 to 11 V
Built-in protection against short-circuits	mA	350 per 4 channels group		
Typical response time	State 0 to 1	ms	3.5	
	State 1 to 0	ms	3.5	
Sensor power supply monitoring	V	≐ 14...18		
Isolation	Between channels		None	
	Between bus and internal logic	V	~ 500	
Consumption	mA	80 with 5-two-wire sensor inputs (1)	130 with 10 two-wire sensor inputs (1)	See consumption page 3/38

(1) + 10 mA per additional input and + 10 mA per 3-wire sensor input.

Outputs characteristics

Type of module		TSX ESF 08T22	TSX EMF 16DT2	
Type of outputs		Solid state	Solid state	
Outputs channels	Number	8 outputs	8 outputs (8 inputs, see page 3/37)	
	Groups of channels	2 groups of 4 channels		
Nominal values	Voltage	V \approx 24		
	Current	A 2	0.5	
Outputs limit values	Voltage	V \approx 19.2...30		
	Current per channel	A 2.5	0.625	
	Current per group At 40 °C of 4 channels	A 8	2	
		At 60 °C	A 4.8	1.2
Leakage current at state 0	mA	< 1		
Residual voltage at state 1	V	< 0.5 to 2 A	< 0.5 to 0.5 A	
Response time	ms	< 0.5 (resistive load)		
Preactuator power supply monitoring	V	\approx 14...18		
Built-in protection	Against overvoltage		Yes, by transil diode	
	Against short-circuits and overloads	A	4.5 by thermal circuit-breaker	1.5 by thermal circuit-breaker
Isolation	Between channels of the same group		Non	
	Between output channel groups	V rms	\sim 60	
	Between output channel groups and internal logic	V rms	\sim 60	
	Between input channels and output channels	V rms	–	\sim 60
	Between bus and internal logic	V	\sim 500	
Consumption	mA	80 with 5 outputs at state 1 (1)	130 with 5 two-wire sensor inputs and 5 output at state 1 (1) (2)	

(1) + 10 mA per additional output at state 1.

(2) + 10 mA per additional input and + 10 mA per 3-wire sensor input.

Connections

TBX EEF 08D2 inputs

Mechanical contacts

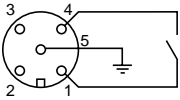

2-wire sensors

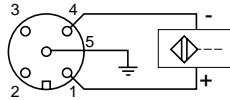

3-wire sensors

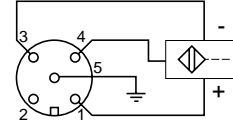

TBX EEF 16D2/TSX EMF 16DT2 inputs

Mechanical contacts

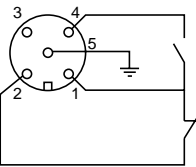

2-wire sensors

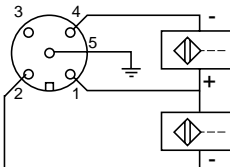

3-wire sensors

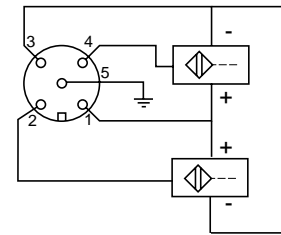

TBX ESF 08T22 outputs

Direct wiring

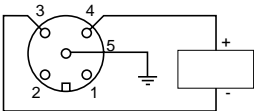

TBX EMF 16DT2 outputs

Direct wiring

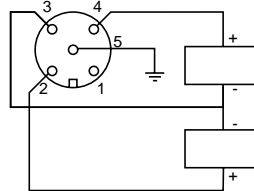

Preactuator power supply

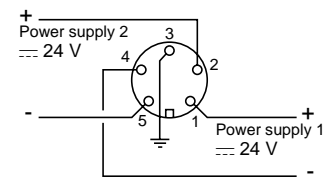

Dimensions, mounting

TSX E●F inputs/outputs

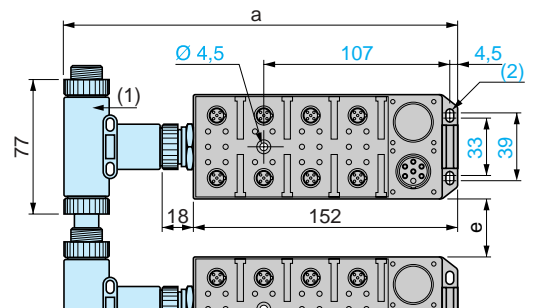
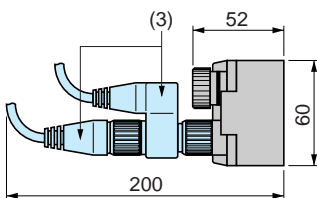

	a	e
TSX E●F + TSX EF CT 03	222	87
TSX E●F + TSX EF CF 03	252	1

(1) TSX EF CT 03
(2) 2 oblongs holes Ø 4.5
(3) TSX EF ACC ●●●●

TSX EF ACC 99 T-junction box

Rear mounting

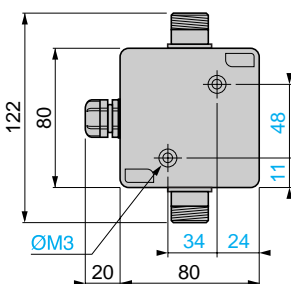

Front mounting

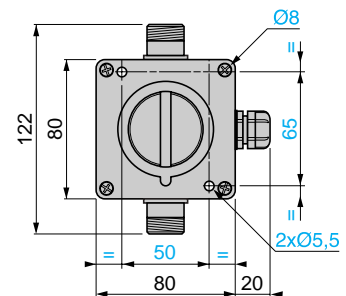
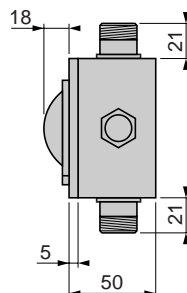

Modicon Premium automation platform

Discrete I/O IP 67 modules on Fipio bus

Dust and damp proof input/output wiring system

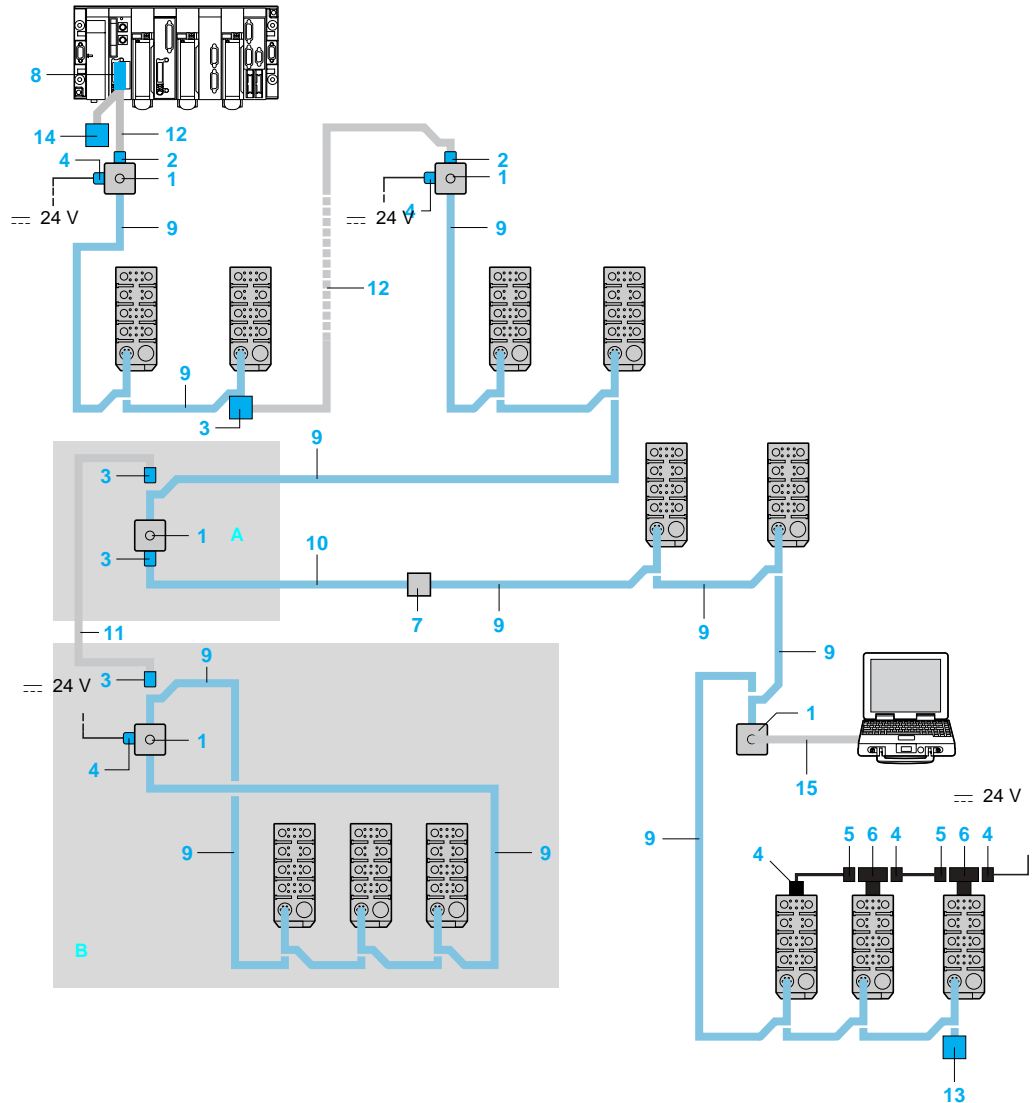

A: Main junction box
B: Remote powered T-junction box

Control of 24 V voltage drop

The dust and damp proof I/O module power supply is carried by Fipio cables, which means that the maximum distance from each TSX EF ACC 99 T-junction box depends on the type of 24 V power supply and the number of I/O modules. The power supply voltage of the last module must be no lower than 19.2 V. Typical voltage drops are given in the table below (1):

Number of input/output modules	m	Distance between T-junction box (used with 24 V remote supply) and last input/output module										
		10	20	30	50	75	100	125	150	200	250	300
5	V	0.09	0.18	0.28	0.46	0.7	0.9	1.2	1.4	1.9	2.3	2.8
10	V	0.17	0.34	0.51	0.86	1.3	1.7	2.1	2.6	3.4	4.3	5.1
15	V	0.25	0.5	0.75	1.25	1.9	2.5	3.1	3.7	5	6.2	7.5
20	V	0.32	0.65	0.98	1.63	2.5	3.3	4	4.9	6.5	8.2	9.8
25	V	0.4	0.8	1.2	2	3	4	5	6	8.1	10	12
30	V	0.48	0.96	1.45	2.4	3.6	4.8	6	7.2	9.6	12	14.5

(1) The typical values are given for connecting 2-wire sensors. If using 3-wire sensors, apply a coefficient of 1.77 to these voltage drop values.

Example:

Use of a 24 V ± 3% power supply.
Over a distance of 100 m and connecting 30 dust and damp proof I/O modules. The voltage drop is $(24 \times 0.97) - 4.8 = 18.48$ V (which is less than the permitted 19.2 V). It is necessary to insert a second 24 V power supply via a TSX EF ACC 99 T-junction box (distance to be defined and verified according to the installation topology).

Modicon Premium automation platform

Discrete I/O IP 67 modules on Fipio bus

T-junction box

- 1 TSX EF ACC 99:** IP 65 Fipio bus T-junction box, used to connect the ± 24 V power supply intended for dust and damp proof I/O. It also has a 9-way female SUB-D connector for an operator terminal. This box also serves as the main Fipio bus junction box **A** as well as for connecting the ± 24 V T-junction power supply (example **B**).

Connectors

- 2 TSX EF CF 01:** IP 67 female soldering connector with M23 type ring, 6-way for connection of Fipio bus and ± 24 V power supply. This type of connector is used at the ends of TSX FP CA/CC/CP/CR ●00 cables.
- 3 TSX EF CM 01:** IP 67 male soldering connector with M23 type ring, 6-way for connection of Fipio bus and ± 24 V power supply. This type of connector is used at the ends of TSX FP CA/CC/CP/CR ●00 cables.
- 4 TSX EF CF 03:** IP 67 female 7/8" type screw connector, 5-way for ± 24 V power supply connection. This type of connector is used for the ± 24 V power supply of the TSX ESF/EMF I/O modules and the TSX EF ACC 99 T-junction box. The maximum current permitted for each connector contact is 8 A.
- 5 TSX EF CM 03:** IP 67 male 7/8" type screw connector, 5-way for connection to a TSX EF CT 03 T-connector used for the ± 24 V preactuator power supply.
- 6 TSX EF CT 03:** IP 67 7/8" type T-connector, 5-way for daisy-chaining the ± 24 V preactuator power supply. The maximum current permitted for each connector contact is 8 A.
- 7 TSX EF CF 02:** IP 67 female soldering connector with M23 type thread, 6-way for extending Fipio TSX FP CP ●00 cables.
- 8 TSX FP ACC 2 or TSX FP ACC 12:** 9-way SUB-D connectors for Fipio/Fipway connection to PLC. Used for daisy chain or tap link connection (90° output high or low, 45° output high or low).

Cables

- 9 TSX EF ACC 2●●●●:** trunk cable, a 150 Ω shielded twisted pair and a 1.5 mm² power supply pair. Fitted with an M23 male connector and a double M23 female/female connector.
- 10 TSX FP CP ●00:** trunk cable, a 150 Ω shielded twisted pair and a 1.5 mm² power supply pair (\varnothing 9.5 mm). Wire ends free to fit IP 67 M23 type soldering connectors TSX CF 01/02 and TSX CM 01.
- 11 TSX FP CC ●00:** tap link cable, double shielded twisted pair 150 Ω (\varnothing 8 mm) for normal environments and use inside buildings. Wire ends free to fit IP 67 M23 type soldering connector TSX CM 01.
- 12 TSX FP CA ●00:** trunk cable, shielded twisted pair 150 Ω (\varnothing 8 mm) for normal environments and use inside buildings.
TSX FP CR ●00: trunk cable, shielded twisted pair 150 Ω (\varnothing 8 mm) for harsh environments and use outside buildings.
Wire ends free to fit IP 67 M23 type soldering connectors TSX CF 01/02 and TSX CM 01.

Other components

- 13 TSX EF ACC 7:** IP 67 M23 type line terminator, to be placed at one or both ends of the segment, depending on the use.
- 14 TSX FP ACC 7:** IP 20 line terminator (set of 2), to be placed at one or both ends of the segment, depending on the use.
- 15 TSX FP CG 0●0:** tap link connecting cable for TSX FPP 10 PCMCIA card for FT 2100 terminal, TSX Micro/Premium PLC and PC compatibles.

Calculation of bus length

The total length of a bus is the sum of all the lengths of the trunk cables plus all the lengths (multiplied by 2) of the tap link cables.
i.e. in the example opposite, the length of the cables is: $\Sigma 12 + \Sigma 9 + \Sigma 10 + (2 \times \Sigma 11)$.

Modicon Premium automation platform

Discrete I/O IP 67 modules on Fipio bus



TSX ESF 08T22



TSX EEF 16D2



TSX EMF 16DT2



TSX EF ACC 99



TSX EF CF 01



TSX EF CM



TSX EF CF 02



TSX EF CT 03



TSX EF ACC7



TSX EF CF 03

Dust and damp proof input/output modules (IP 67)

Number of I/O	No, type of inputs	No, type of outputs	Inputs characteristics	Connection via	Reference	Weight kg
8	8, --- 24 V	–	IEC type 2 positive logic	8 female M12 connectors	TSX EEF 08D2	0.500
		8, solid state --- 24 V/2A		8 female M12 connectors	TSX ESF 08T22	0.540
16	16, --- 24 V	–	IEC type 2 positive logic	8 female M12 connectors	TSX EEF 16D2	0.500
		8, --- 24 V	8, solid state --- 24 V/0.5A	IEC type 2 positive logic	8 female M12 connectors	TSX EMF 16DT2

Fipio bus connection accessories

Type	Use	No. (1)	Reference	Weight kg
Fipio bus T-junction box				
M23 male M23 female 7/8" male	Trunk cable tap-off via two M23 connectors Remote --- 24 V power supply distribution via 7/8" connector PC compatible terminal connection via 9-way female SUB-D 9 connector	1	TSX EF ACC 99	0.715

M23 type soldering connectors

Female	Equipment for TSX FP CA/CC/CP bus cables	2	TSX EF CF 01	0.080
Male	Equipment for TSX FP CA/CC/CP bus cables	3	TSX EF CM 01	0.080
Female	Extension for TSX FP CA bus trunk cables	7	TSX EF CF 02	0.075

7/8" type screw connectors

Female	Equipment for --- 24 V preactuator power supply	4	TSX EF CF 03	0.050
Male	Equipment for --- 24 V preactuator power supply	5	TSX EF CM 03	0.050
T	--- 24 V preactuator power supply daisy chain on TSX E●F I/O modules	6	TSX EF CT 03	0.095

M23 type line terminator

Male	To place at the ends of the Fipio segment requiring IP 67 protection	13	TSX EF ACC 7	0.085
------	--	----	---------------------	-------

IP 20 connection accessories for Fipio bus

Type	Use	No. (1)	Reference	Weight kg
9-pin SUB-D connectors				
Female zamac	Bus connection for Fipio manager output on Premium PLCs	8	TSX FP ACC 2	0.080
Female insulating	Bus connection for Fipio manager output on Premium PLCs	8	TSX FP ACC 12	0.040
Line terminator (set of 2)				
2-wire connection	To place at the ends of the Fipio segment (IP 20 protection)	14	TSX FP ACC 7	0.020

Other Fipio accessories

See page 5/102 –

(1) For key to numbers, see pages 3/40 et 3/41.

Modicon Premium automation platform

Discrete I/O IP 67 modules on Fipio bus



TSX EF ACC 20●●

Fipio bus connecting cables

Type	Use	No. (1)	Length	Reference	Weight kg
Trunk cables with M23 moulded connections (patented)					
Ø 9.5 mm, 1 shielded twisted pair, 1 pair, 1.5 mm ² for remote power supply	Fipio bus and 24 V power supply	9	0.2 m	TSX EF ACC 2002	0.245
	Equipped with 1 male M23 connector and 1 double female M23 connector		1 m	TSX EF ACC 2010	0.340
			3 m	TSX EF ACC 2030	0.580
			7 m	TSX EF ACC 2070	1.020
			12 m	TSX EF ACC 20120	1.645
			25 m	TSX EF ACC 20250	3.180

Trunk cables to be fitted with M23 connectors

Ø 8 mm, 1 shielded twisted pair	Fipio bus, for use in normal environments (2) inside buildings	12	100 m	TSX FP CA 100	5.680
			200 m	TSX FP CA 200	10.920
			500 m	TSX FP CA 200	30.000
Ø 9.5 mm, 1 shielded twisted pair, 1 pair, 1.5 mm ² for remote power supply	Fipio bus, for use in harsh environments (3) and outside buildings or in garland (3)	12	100 m	TSX FP CR 100	7.680
			200 m	TSX FP CR 200	14.920
			500 m	TSX FP CR 500	40.000
Ø 9.5 mm, 1 shielded twisted pair, 1 pair, 1.5 mm ² for remote power supply	Fipio bus and 24 V power supply To be fitted with M23 connectors, according to use	10	100 m	TSX FP CP 100	5.680
			500 m	TSX FP CP 500	30.000

Tap-off cables

Ø 8 mm, 2 shielded twisted pairs	Fipio bus tap-off (between 2 TSX EF ACC 99 T-junction boxes)	11	100 m	TSX FP CC 100	5.680
			200 m	TSX FP CC 200	10.920
			500 m	TSX FP CC 500	30.000

Replacement parts

Use	Unit reference	Weight kg
Strip of 10 referencing labels		
For referencing I/O modules and I/O channel connectors	XZ LG101	0.010
IP 67 seling plugs		
For M12 type connectors (order in multiples of 10)	XZ LG102	0.005
For M23 type connectors	170 XTS 050 00	0.140

(1) For key to numbers, see pages 3/39 et 3/41.

(2) Normal environment:

- without special environmental restrictions,
- operating temperature between + 5 °C and + 60 °C,
- fixed installations.

(3) Harsh environment:

- resistance to hydrocarbons, industrial oils, detergents, solder splashes,
 - up to 100 % humidity,
 - saline environment,
 - significant variations in temperature,
 - operating temperature between - 10 °C and + 70 °C,
 - mobile installations,
 - Use in garland: radius of curvature = 10 x cable diameter (either 80 or 95 mm).
- For other special restrictions, please consult your Regional Sales Office.

Presentation

Decentralising the I/O meets the requirements of both users and machine manufacturers while maintaining performance comparable with that of a centralised structure.

Momentum dust and damp proof distributed I/O modules (IP 65) are used to create, via the INTERBUS bus, distributed control systems, which offer increased availability of installations. They also offer the possibility of locating the I/O interfaces close to the process or machines, in harsh environments (water jets, dust, etc).

These 170 ED● modules must be controlled by an INTERBUS master module, such as the TSX IBY 100 Premium PLC module or TSX IBX 100 coprocessor. They are only connected to an installation remote bus. The installation remote bus terminal module is used for the tap link to this installation remote bus.

Momentum dust and damp proof distributed I/O modules with 16 x $\text{---} 24 \text{ V}$ inputs or 16 x 0.5 A/ $\text{---} 24 \text{ V}$ outputs offer:

- Compact interface elements.
- Easy setup and connection.

Momentum dust and damp proof distributed I/O modules have been designed to conform with the main international standards concerning electronic industrial control equipment:

- Specific requirements for programmable controllers: operating characteristics, immunity, ruggedness, safety etc.
- NF C 63 850, IEC 1131 2.
- Immunity to electrostatic discharges: IEC 801.2 level 4.

These products, marked CE, satisfy the requirements of the European directives and conform to the applicable harmonised standards.

These products are approved by the INTERBUS club.

Description

Momentum dust and damp proof distributed I/O modules 170 ED● 346 00 are monobloc type in an IP 65 casing and comprise :

- 1 A 9-way connector for connection to the installation remote bus (in).
- 2 A 9-way connector for connection to the installation remote bus (out).
- 3 16 status indicator lamps for inputs or outputs.
- 4 Two holes for fixing the module on a mounting plate.
- 5 Eight connectors for input or output channels.
- 6 A $\text{---} 24 \text{ V}$ auxiliary power supply connector (for the 170 ED0 346 00 output module).
- 7 Three or four diagnostics indicators (depending on the model).
- 8 Space for self-adhesive identification label.

Connector to be ordered separately:

- For output modules, TBX BAS 10 dust and damp proof power supply connector.

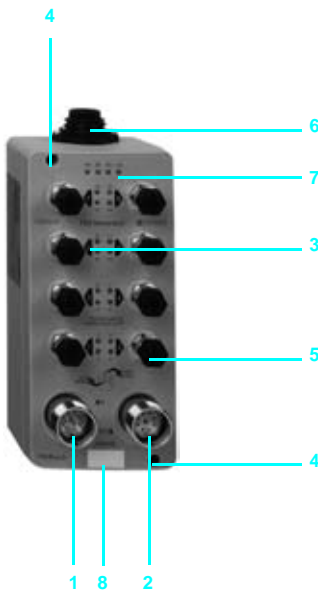

Connection principle

Momentum dust and damp proof distributed I/O modules are connected to the installation remote bus of an INTERBUS bus. This installation remote bus is a tap link of the remote bus to which a 24 V power supply is added via an installation remote bus terminal module.

The number of I/O modules on the installation remote bus is limited by the current consumption of the modules and connected sensors. Total consumption should not exceed 4.5 A. The current consumption of the actuators is not included in the calculation, since these are supplied separately.

The maximum length of the installation remote bus cable is:

- Between the installation remote bus terminal module and the first I/O module: 50 m.
- Between two I/O modules: 50 m.
- Between the installation remote bus terminal module and the last I/O module: 50 m.

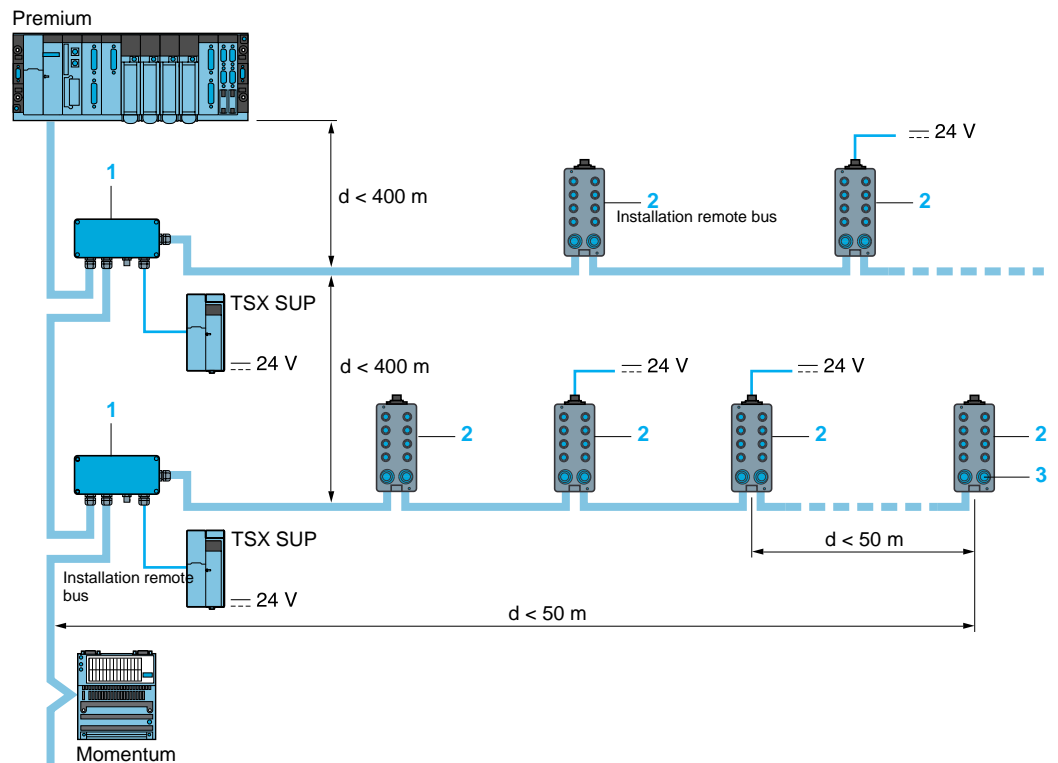

- 1 Installation remote bus terminal module 170 ENO 396 00.
- 2 Dust and damp proof distributed I/O module 170 ED● 346 00.
- 3 Sealing plug 170 XTS 050 00.

3

3.2

Type of input module				170 EDI 346 00
Modularity				16
Nominal input values	Voltage	--- V	24	
	Current	mA	100 (0 % active inputs), 640 (100 % active inputs)	
	Sensor supply (ripple included)	--- V	19.2...30	
Input limit values	At state 1	Voltage	V ≥ 11	
		Current	mA 2.5...10	
	At state 0	Voltage	V < 5	
		Current	mA < 2	
Input impedance				kΩ 3.6
Logic				Positive
Response time	Change from state 0 to state 1	ms	5	
	Change from state 1 to state 0	ms	5	
Dissipated power	Per module	W	1.9 (0 % active inputs), 2.5 (100 % active inputs)	
	Per channel	W	0.3	
Compatibility with INTERBUS output module				Yes
Isolation	Dielectric strength between inputs and earth	--- V	750 for 1 min	
	Insulation resistance	MΩ	> 10 at $\text{--- } 500 \text{ V}$	
Temperature	Operation	°C	0...60	
	Storage	°C	- 25...+ 70	
Relative humidity	Without condensation		5...95 %	
Altitude				m 0...2000
Degree of protection				IP 65
Type of output module				170 EDO 346 00
Modularity				16
Loads	Voltage	--- V	24	
	Nominal current	A	0.5	
Limit values	Voltage (ripple included)	--- V	19.2...30	
Logic				Positive
Response time	Change from state 0 to state 1	ms	5	
	Change from state 1 to state 1	ms	5	
Leakage current	At state 0	mA	< 1	
Residual voltage	At state 1	V	< 0.5	
Built-in protection	Against short- circuits		Yes (thermal)	
	Against overloads		Automatic reset	
Typical currents consumed	Mains power supply	mA	200 (0 % active outputs), 380 (100 % active outputs)	
	Auxiliary power supply	mA	180 (0 % active outputs), 220 (100 % active outputs)	
Dissipated power	Per module	W	1.9 (0 % active outputs), 3 (100 % active outputs)	
Compatibility with INTERBUS input module				Yes
Isolation	Dielectric strength between outputs and earth	--- V	750 for 1 min	
	Insulation resistance	MΩ	> 10 at $\text{--- } 500 \text{ V}$	
Temperature	Operation	°C	0...60	
	Storage	°C	- 25...+ 70	
Relative humidity	Without condensation		5...95 %	
Altitude				m 0...2000
Degree of protection				IP 65



170 EDI 346 00



170 EDO 346 00

References

Dust and damp proof monobloc distributed discrete I/O modules

Type of module	Operating voltage	Modularity (nb of chan.)	IEC 1131 2 Conformity	Reference (1)	Weight kg
Inputs	24 V (pos.log.)	16 isolated inputs	Type 1	170 EDI 346 00	0.520
Outputs	24 V	16 protected 0.5 A outputs	Yes	170 EDO 346 00	0.580

Accessoires de raccordement

Description	Use	Reference (1)	Weight kg
Installation remote bus terminal module (1)	Tap-off from remote bus to installation remote bus Enables communication of distributed I/O and INTERBUS master module	170 ENO 396 00	-
Sealing plug	To be fitted at end of installation remote bus	170 XTS 050 00	0.140
Dust and damp proof power supply connector for output module	24 V preactuator power supply for 170 EDO 346 00 output module	TBX BAS 10	0.120

Connection cables

Description	Length	Reference (1)	Weight kg
Installation remote bus cables preformed with dust and damp proof M23 connectors, composite pure material	0.4 m	TSX IBI CP DD9 004	-
	1 m	TSX IBI CP DD9 010	-
	3 m	TSX IBI CP DD9 030	-
	7 m	TSX IBI CP DD9 070	-
	12 m	TSX IBI CP DD9 120	-
	25 m	TSX IBI CP DD9 250	-

Documentation

Description	Language	Reference	Weight kg
Installation manual	English	870 USE 100 00	-

(1) Product supplied with multilingual Quick Reference Guide .

Connections, dimensions, mounting

170 EDI 346 00 inputs

Mechanical contacts

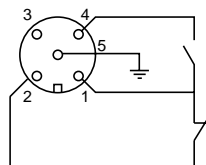

2-wire sensors

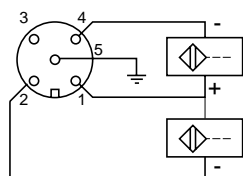

3-wire sensors

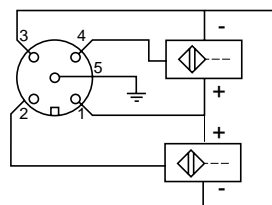

170 EDO 346 00 outputs

Direct wiring

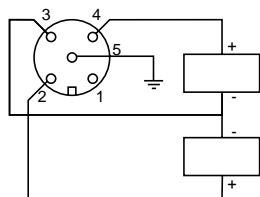

Wiring with amplification

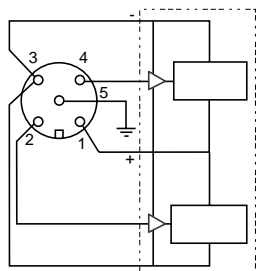

Preactuator supply via TBX BAS 10 connector

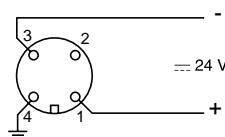

Dimensions, mounting

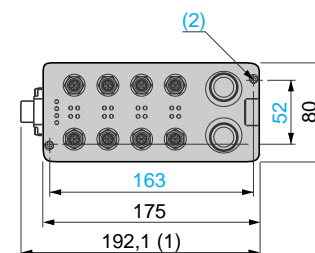

(1) For 170 EDO 346 00 module.

(2) 2 holes for M4 x 16 screws.

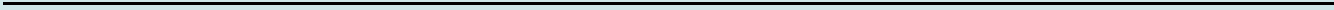

4.1 - Analog I/O modules and process control

Selection guide analog I/O modules page 4/2

- TSX A●Y analog I/O modules page 4/4
- Process control page 4/10

4.2 - Application-specific counter modules

Selection guide counter and electronic cam modules page 4/18

Selection guide motion control modules page 4/20

- TSX CTY 2A/4A counter modules page 4/22
- TSX CTY 2C measurement and counter module page 4/26
- TSX CCY 1128 electronic cam modules page 4/30

4.3 - Application-specific motion control modules

- TSX CFY 11/21 modules for stepper motors page 4/34
- TSX CAY modules for servomotors page 4/38
- Motion control modules software setup page 4/48
- SERCOS TSX CSY 84/164 motion control modules page 4/50
- Lexium offer presentation page 4/58

4.4 - Application-specific weighing modules and solution

- ISP Plus integrated weighing system page 4/60
- TSX ISP weighing modules page 4/62

4.5 - Redundancy

- Warm Standby redundancy page 4/66



Modicon Premium automation platform

Analog I/O modules

4
1.1

Applications		Analog inputs		
Type of I/O		Low level isolated inputs, thermocouples, temperature probes	Thermocouple inputs	High level inputs with common
Type		Multirange	Multirange	Voltage/current
Range		Voltage $\pm 10\text{ V}, \pm 5\text{ V}, 0\dots 10\text{ V}, 0\dots 5\text{ V}, 1\dots 5\text{ V}$ Current $4\dots 20\text{ mA}, 0\dots 20\text{ mA}$, external shunt supplied Thermocouple, temperature probes B, E, J, K, L, N, R, S, T, U thermocouples Pt 100, Pt 1000, Ni 1000, 2 or 4 -wire temperature probes	$- 80\dots + 80\text{ mV}$ – Thermocouples B, E, J, K, L, N, R, S, T, U	$\pm 10\text{ V}, 0\dots 10\text{ V}, 0\dots 5\text{ V}, 1\dots 5\text{ V}$ $0\dots 20\text{ mA}, 4\dots 20\text{ mA}$
Modularity		4 channels	16 channels	8 channels
Isolation		Between channels: $\sim 2830\text{ V rms}$ Between bus and channels: $\sim 1780\text{ V rms}$ Between channels and earth: $\sim 1780\text{ V rms}$	Between channels: $\pm 100\text{ V}$ Between bus and channels: $\sim 1000\text{ V rms}$ Between channels and earth: $\sim 1000\text{ V rms}$	Between channels: common point Between bus and channels: $\sim 1000\text{ V rms}$ Between channels and earth: $\sim 1000\text{ V rms}$
Read time		550 ms	1120 ms (normal scan) 70 ms/channel used (fast scan)	27 ms (normal scan) 3 ms/channel used (fast scan)
Response time		User-definable filtering 0 to 68.5 s	User-definable filtering 0.04 Te to 0.012 Te (Te: module scan time)	User-definable filtering 0 to 3.44 s
Resolution		16 bits	16 bits	12 bits
Connection		20-way screw terminal: TSX BLY 01	Two 25-way SUB-D connectors or 2 Telefast 2 sub-bases (ABE 7CPA12)	25-way SUB-D connector or 1 Telefast 2 sub-base (ABE 7CPA02/03)
Type of module		TSX AEY 414	TSX AEY 1614	TSX AEY 800
Pages		4/8		

High level inputs



point

High level isolated inputs between channels

High level input with common point

Analog outputs



Isolated outputs between channels

Outputs with common point

Voltage/current

± 10 V

0...20 mA,
4...20 mA

16 channels	8 channels	4 channels	8 channels	
Between channels: common point. Between bus and channels: ~ 1000 V rms Between channels and earth: ~ 1000 V rms	Between channels: ± 200 V Between bus and channels: ~ 1000 V rms Between channels and earth: ~ 1000 V rms	Between channels: common point Between bus and channels: ~ 1000 V rms Between channels and earth: ~ 1000 V rms	Between channels: ~ 1500 V rms Between bus and channels: ~ 1500 V rms Between channels and earth: ~ 1500 V rms	Between channels: common point Between bus and channels: ~ 1000 V rms Between channels and earth: ~ 1000 V rms
51 ms (normal scan) 3 ms/channel used (fast scan)	126.4 ms (normal scan) 3.3 ms/channel used (fast scan)	1 ms	–	–
User-definable filtering 0 to 6.50 s	User-definable filtering 0 to 3.82 s	–	2.5 ms	5 ms
12 bits	16 bits	–	11 bits + sign	13 bits + sign for voltage 13 bits for current
Two 25-way SUB-D connectors or via 2 Telefast 2 sub-bases (ABE 7CPA02/03)	25-way SUB-D connector or 1 Telefast 2 sub-base (ABE 7CPA02/31)	25-way SUB-D connector or 1 Telefast 2 sub-base (ABE 7CPA03/21)	20-way screw terminal: TSX BLY 01	25-way SUB-D connector or 1 Telefast 2 sub-base (ABE 7CPA02)
TSX AEY 1600	TSX AEY 810	TSX AEY 420	TSX ASY 410	TSX ASY 800

4/8

4
4.1

Presentation

Analog I/O modules for Premium PLCs are equipped with :

- Either one 25-way SUB-D connector (TSX AEY 420/800/810 and TSX ASY 800)
- Or two 25-way SUB-D connectors (TSX AEY 1600/1614)
- Or a screw terminal block (TSX AEY 414, TSX ASY 410)

They can be installed in any position in TSX RKY ●●● racks except for the positions reserved for power supply modules. Analog I/O modules can be removed while the PLC is powered up.

The maximum number of analog channels in a Premium configuration depends on the processor used, see pages 1/16 and 1/17, 1/22 and 4/17.

Description

The front panels of TSX AEY/ASY analog I/O modules comprise:

- 1 A display and module diagnostics block.
- 2 A connector for receiving the screw terminal block.
- 3 A rotating support containing the module locating device.
- 4 A removable screw terminal for direct connection of the I/O to the sensors and preactuators TSX BLY 01 (to be ordered separately).
- 5 A pivoting cover for accessing the terminal block screws and holding the identification label.
- 6 A screw terminal block encoder.
- 7 A 25-way SUB-D connector for connecting the sensors.

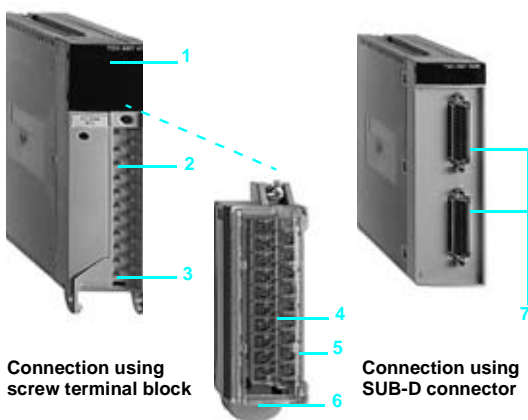

Nota : The TSX ASY 800 modules have on the front panel a screw terminal for external 24 VR connection. See page 4/8.

Connection principle for TSX AEY/ASY modules with SUB-D connector

The Telefast 2 pre-wired system simplifies the installation of modules by providing access to the inputs (or outputs) at the screw terminals. Connection is via a TSX CAP 030 3 metre shielded cable equipped with SUB-D connectors at either end.

- The Telefast ABE 7CPA02 sub-base enables 8 channels to be connected.
- The Telefast ABE 7CPA03/31 sub-base enables the connection of 8 channels and:
 - provides channel by channel supply for 2 and 4-wire sensors with --- 24 V (for sub-base ABE 7CPA03),
 - channel by channel isolated supply for 2 and 4-wire 24 V sensors (for sub-base ABE 7CPA31),
 - ensures continuity of current loops when the SUB-D connector is removed,
 - protects the current shunt within the modules against overvoltages.
- The Telefast ABE 7CPA12 sub-base enables 16 thermocouples to be connected. The terminal block is fitted with a temperature probe for cold junction compensation.

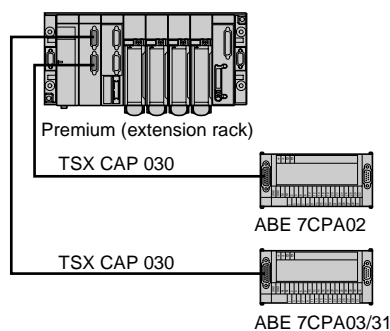

TSX AEY 420, 800/810, 1600 analog input modules

TSX AEY ●●● modules are high level analog input modules with 4 inputs for the TSX AEY 420 module, 8 inputs for TSX AEY 800/810 modules and 16 inputs for the TSX AEY 1600 module.

Used with sensors or transmitters, they perform monitoring, measurement and process control functions for continuous processes.

Depending on the choice made during configuration, TSX AEY 420/800/810/1600 modules offer the following ranges for each of their inputs ± 10 V, 0...10 V, 0...5 V, 1...5 V, 0...20 mA, 4...20 mA.

Functions

- Scanning of input channels, protection against overvoltages, adaptation of signals by analog filtering, scanning by solid state multiplexing.
- Adaptation to input signals: gain selection, drift compensation.
- Digitisation of signals: 12-bit analog/digital conversion for TSX AEY 800/1600 and 16 bit analog/digital conversion for TSX AEY 420/810.
- Converting input measurements to user format: recalibration coefficient, filtering, scaling.
- Module monitoring: conversion circuit test, range overshoot test, terminal block presence test, "watchdog" test.
- Isolation of input channels on TSX AEY 810.
- Fast processing of inputs (1 ms) on TSX AEY 420.

TSX AEY 414/1614 analog input modules

The TSX AEY 414 module is a multirange input module with 4 channels isolated from each other.

Depending on the choice made during configuration, the following ranges are available for each of its inputs:

- thermocouples B, E, J, K, N, R, S, T, U or - 13...+ 63 mV electrical range.
- 2 or 4-wire Pt 100, Pt 1000, Ni 1000 temperature probe, or ohmic range: 0...400 ohms, 0...3850 ohms.
- High level ± 10 V, 0...10 V, ± 5 V, 0...5 V (0...20 mA with external shunt) or 1...5 V, 4...20 mA (4...20 mA with external shunt).
- The TSX AEY 1614 module is an analog input module with 16 thermocouple inputs. Depending on the selections made during configuration, the following range is available for each of the input channels (supporting a common mode between them of ≈ 250 V or ~ 280 V):
- Thermocouples B, E, J, K, L, N, R, S, T or U, or electrical range - 80 mV... + 80 mV

Functions

- Scanning of input channels, gain selection according to input signals, multiplexing.
- Digitisation of input signals.
- Converting input measurements to user format: recalibration coefficient, linearisation, cold junction compensation, filtering, scaling.
- Module monitoring: conversion circuit test, range overshoot test, terminal block presence test, sensor link test, "watchdog" test.

TSX ASY 410, 800 analog output modules

The TSX ASY 410 module has 4 analog outputs isolated from each other, and the TSX ASY 800 module has 8 outputs with common point.

Depending on the choice made during configuration, the modules offer the following range for each of its inputs: ± 10 V, 0...20 mA and 4...20 mA without external supply.

Functions

- Protection of the module against overvoltages.
- Adaptation to the different actuators: voltage or current output.
- Conversion of digital signals to analog signals (11 bits + sign for TSX ASY 410 and 13 bits + sign for TSX ASY 800).
- Transforming application data into data which can be used by the digital/analog converter.
- Module monitoring and fault indication to the application: converter test, range overshoot test, terminal block presence test, "watchdog" test.

PL7 Junior software performs configuration and debugging functions:

- Choice of modules used.
- Configuration of channels according to the type of module: scanning (normal or fast), cold junction compensation (internal or external), range, filtering, display format, task (MAST or FAST), detection of terminal block presence, wiring check.
- Debugging, access to certain parameter settings, module/channel diagnostics, forcing, calibration.

4
1.1

Characteristics of analog input modules				TSX AEY 800	TSX AEY 1600	TSX AEY 810	TSX AEY 420				
Type of input module				8	16	8	4				
Number of channels				8	16	8	4				
Input range				± 10 V, 0...10 V, 0...5 V, 1...5 V, 0...20 mA, 4...20 mA							
Analog/digital conversion				12 bits		16 bits					
Read time	Normal scan	ms	27	51	29.7		1				
	Fast scan	ms	3 x (no. of channels used + 1)		3.3 x (no. of channels used + 1)		–				
Max. error			± 10 V 0...10 V	0...5 V 1...5 V	0...20 mA 4...20 mA	± 10 V 0...10 V	0...5 V 1...5 V	0...20 mA 4...20 mA			
	At 25 °C	%FS	0.19/0.1 (1)	0.15/0.1 (1)	0.25/ 0.16 (1)	0.244	0.13	0.142	0.1	0.2	0.2
	0...60 °C	%FS	0.22/ 0.13 (1)	0.22/0.13 (1)	0.41/ 0.32 (1)	0.305	0.191	0.12	0.2	0.4	0.4
Isolation	Betw. ch. and bus	V rms	1000								
	Betw. ch. and earth	V rms	1000								
	Between channels	V	Common point			± 200		Common point			
Common mode between channels			None			± 200		None			
Max. overvoltage/overcurrent on the inputs			± 30 V voltage ± 30 mA en current								
Standards			IEC 1131								
Consumption		mA	See page 8/4								

Type of input module		TSX AEY 414	
Number of channels		4	
Input range		<ul style="list-style-type: none"> ■ B, E, J, K, L, N, R, S, T, U thermocouples or electrical range : - 13...+ 63 mV ■ Pt 100, Pt 1000, Ni 1000 2 or 4-wire temperature probes, or ohmic range: 0...400 Ω, 0...3850 Ω ■ ± 10 V, 0...10 V, ± 5 V, 0...5 V (0...20 mA with external shunt) or 1...5 V, 4...20 mA (4...20 mA with external shunt) 	
Analog/digital conversion		16 bits	
Read time	Normal scan	ms	550
	Fast scan	ms	–
Max. error	At 25 °C	%FS	See page 4/7
	0...60 °C	%FS	See page 4/7
Isolation	Betw. ch. and bus	V rms	1780
	Betw. ch. and earth	V rms	1780
	Between channels	V rms	2830
Common mode		V	~ 240 or ~ 100 between channels and earth ~ 415 or ~ 200 between channels
Max. overvoltage/overcurrent on the inputs			± 30 V powered up without 250 Ω external resistance ± 15 V powered down without 250 Ω external resistance ± 25 mA powered up/down without 250 Ω external shunt
Standards			Sensor: IEC 584, IEC 751, DIN 43760, DIN 43710, NFC 42 330 PLC: IEC 1131
Consumption		mA	See page 8/4

(1) The 1st value corresponds to the max. error of the TSX AEY 800 module, the 2^d, to the TSX AEY 1600.

Input range for TSX AEY 414													
Voltage/current range			± 10 V	0...10 V	± 5 V	0...5 V	1...5 V	0...20 mA	4...20 mA	13...63 mV	0...4000 Ω	0...3850 Ω	
Max. error at 25 °C		%FS (1)	0.27	0.16	0.27	0.22	0.27	0.36	0.45	0.19	0.13	0.22	
Max. error at 0...60 °C		%FS (1)	0.50	0.39	0.50	0.45	0.56	0.69	0.86	0.44	0.27	0.48	
Temperature probe range			Pt 100			Pt 1000		Ni 1000					
Max. error at 25 °C		°C	1.2			2.5		1					
Max. error at 0...60 °C		°C	2.4			5		2					
Thermocouple range			B	E	J	K	L	N	R	S	T	U	
Max. error at 25 °C		CI (2)	°C	3.5	6.1	7.3	7.8	7.5	6	6	6.6	6.6	5.4
		CE (3)	°C	1.5	1.5	1.8	2.3	2	2	3.2	3.4	1.5	1.5
Max. error at 0...60 °C		CI (2)	°C	8.1	8.1	9.5	10.5	9.8	8.7	11	12	8.8	7.3
		CE (3)	°C	3.5	3.2	3.8	4.7	4.1	4.3	7.7	8.5	3.2	3.1

Input range for TSX AEY 1614												
Thermocouple range			B	E	J	K	L	N	R	S	T	U
Max. error at 25 °C (4)		°C	2.5	0.8	0.9	1	0.9	1.1	2.1	2.2	1	1
Max. error at 0...60 °C (4)		°C	4	1.2	1.4	1.6	1.4	1.7	2.4	3.7	1.3	1.3

Characteristics of analog output modules

Type of output module		TSX ASY 410	TSX ASY 800
Number of channels		4	8
Output range		± 10 V, 0...20 mA and 4...20 mA, output supplied by PLC (or 24 V SELV external on TSX ASY 800, see page 2/63)	
Analog/digital conversion		11 bits + sign	13 bits + sign (voltage), 13 bits current
Conversion time	ms	2,5	5
Maximum resolution		Voltage output 5.12 mV (5), current output 10.25 µA (6)	Voltage output 1.28 mV, current output 2.56 µA
Output load		Voltage output, impedance > 1 kΩ, load < 0.1 µF, current output, impedance < 600 Ω, load < 300 µH	
Measurement error as a % of FS			
Voltage output, FS = 10 V	%FS	0.45 to 25 °C, 0.75 from 0 to 60 °C	
Current output, FS = 20 mA	%FS	0.52 to 25 °C, 0.98 from 0 to 60 °C	
Isolation between channels and bus	V rms	1500	1000
Isolation between channels and earth		≈ 500 V	1000 V rms
Isolation between channels	V rms	1500	Common point
Type of protection		Short-circuits and overload	
Max. voltage without damage	V	± 30	
Standards		IEC 1131	
Consumption	mA	See page 8/4	

- (1) %FS: error as a % of full scale.
 (2) IC: with internal cold junction compensation.
 (3) EC: with external cold junction compensation (with class A Pt 100 probe on channel 0).
 (4) Max. errors, regardless of type of internal or external cold junction compensation (via Telefast sub-base or with class A Pt 100 probe).
 (5) Value given for TSX ASY 410 (software version: II > 10), for TSX ASY 410 (software version: II ≤ 10). This value is 4.88 mV.
 (6) Value given for TSX ASY 410 (software version: II > 10), for TSX ASY 410 (software version: II ≤ 10). This value is 9.77 µA.

Modicon Premium automation platform

Analog I/O modules



TSX AEY 800/420



TSX AEY 1600/1614



TSX ASY 410/AEY 414



TSX ASY 800

Analog input modules

Type of inputs	Input signal range	Resolution	Connection	No. of channels	Reference (1)	Weight kg
Analog, high level with common point	± 10 V, 0...10 V, 0...5 V, 1...5 V, 0...20 mA, 4...20 mA	16 bits	1 x 25-way SUB-D connector	4 fast channels	TSX AEY 420	0.330
Analog, low level isolated	± 10 V, 0...10 V, 0...5 V, 1...5 V, ± 5 V, 0...20 mA, 4...20 mA, - 13...+ 63 mV, 0...400 Ω , 0...3850 Ω , temperature probe, thermocouple	16 bits	Screw terminal block (2)	4 channels	TSX AEY 414	0.320
Analog, high level with common point	± 10 V, 0...10 V, 0...5 V, 1...5 V, 0...20 mA, 4...20 mA	12 bits	1 x 25-way SUB-D connector	8 channels	TSX AEY 800	0.310
			2 x 25-way SUB-D connectors	16 channels	TSX AEY 1600	0.340
Analog, low level isolated	± 10 V, 0...10 V, 0...5 V, 1...5 V, 0...20 mA, 4...20 mA	16 bits	1 x 25-way SUB-D connector	8 channels	TSX AEY 810	0.330
Thermocouple	± 63 mV, (B, E, J, K, L, N, R, S, T, U)	16 bits	2 x 25-way SUB-D connectors	16 channels	TSX AEY 1614	0.350

Analog output modules

Type of outputs	Output signal range	Resolution	Connection	No. of channels	Reference (1)	Weight kg
Analog, isolated	± 10 V, 0...20 mA, 4...20 mA	11 bits + sign	Screw terminal block (2)	4 channels	TSX ASY 410	0.350
Analog with common point	± 10 V, 0...20 mA, 4...20 mA	13 bits + sign	1 x 25-way SUB-D connector	8 channels	TSX ASY 800 (3)	—

(1) Product supplied with a bilingual Quick Reference Guide: English and French.

(2) TSX BLY 01 screw terminal block not supplied. To be ordered separately.

(3) The number of TSX ASY 800 modules is limited to 1 per rack with standard format power supply, to 2 per rack with double format power supply (when this supplies the ± 24 V voltage required by outputs).

Modicon Premium automation platform

Analog I/O modules



ABE-7CPA0

Connection accessories

Description	Compatible with module	Use	Type of terminal block	Reference (1)	Weight kg	
Telefast 2 sub-bases	TSX AEY 800 TSX AEY 810 TSX AEY 1600 TSX ASY 800 (2)	Distribution of 8 channels on screw terminals	Screw	ABE 7CPA02	0.290	
	TSX AEY 420 TSX AEY 800 TSX AEY 1600	Distribution of 8 channels with common point on screw terminals, protected sensor supply, continuity of current loops during disconnection, protection against overvoltages	Screw	ABE 7CPA03	0.330	
	TSX AEY 810	Distribution of 8 isolated channels on screw terminals, channel by channel sensor supply (without common point), protection against overvoltages	Screw	ABE 7CPA31	0.410	
	TSX AEY 1614	Distribution of 16 channels on screw terminals, integrates temperature probe for external cold junction compensation	Screw	ABE 7CPA12	0.360	
			Spring	ABE 7CPA31E	0.410	
Connection cables	TSX AEY 420 TSX ASY 410 (3)	Distribution of 4 channels on screw terminals	Screw	ABE 7CPA21	0.200	
	TSX AEY 420 TSX AEY 800 TSX AEY 810 TSX AEY 1600 TSX AEY 1614 (4)	Link between 25-way SUB-D connectors of analog I/O modules and ABE 7CPA sub-bases Length 3 m	–	TSX CAP 030	0.670	
	TSX ASY 410	Link between module and ABE 7CPA21 sub-bases (5)	1.5 m	–	ABF Y25S150	0.500
			2 m	–	ABF Y25S200	0.560
			3 m	–	ABF Y25S300	0.740
			5 m	–	ABF Y25S500	0.920
Screw terminal 20-way	TSX AEY 414 TSX ASY 410	To be ordered separately with each I/O module for connection via screw terminal block	Screw	TSX BLY 01	0.100	
Set of 4 resistors	TSX AEY 414	Adaptation for current range (supplied with TSX AEY 414)	–	TSX AAK2	0.020	



TSX BLY 01

(1) Product supplied with a bilingual quick reference guide: French and English.

(2) Can be used with TSX AEY 420 module.

(3) Can be used with TSX ASY 410 module by using the ABF Y25S cables.

(4) Necessity to use two TSX CAP 030 cables to connect the ABE 7CPA12 sub-base.

(5) Includes the TSX BLY 01 20-way screw terminal block.

Modicon Premium automation platform

Process control

The process control range integrated as standard in Premium platforms enables the setup and debugging of process control loops specifically designed for machine control.

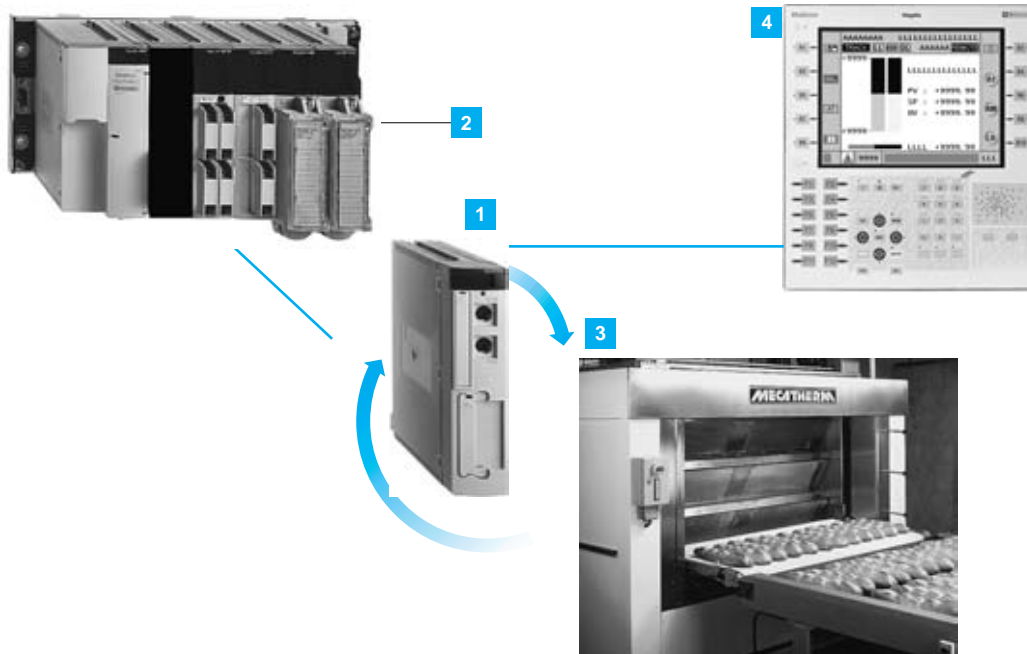

4
1.1

User-definable process control functions

TSX P57 2●3/2●23/3●3/3623/453/4823M processors and T PCX 57 203/353M coprocessors can be used, depending on the model, to manage 10 to 20 control channels (of 3 loops each).

These channels can be configured in order to execute algorithms used in industrial processes:

- Cascaded loop.
- Process loop.
- Autoselective loop.
- Setpoint programmer.
- Controller with three simple loops.

Inputs/outputs

TSX P57 2●3/2●23/3●3/3623/453/4823M processors and TPCX 57 203/353M coprocessors manage an entire station consisting of racks connected on Bus X. The I/O interfaces necessary for process control processing are analog or discrete module channels in:

- In-rack I/O modules.
- TBX or Momentum distributed I/O modules.

Control loops

The software setup of control loops is performed by entering parameters (Plug and Play technology) when configuring the TSX P57/T PCX 57 processor or coprocessor.

The user completes predefined loop diagrams which also integrate management of the operating mode and the link with the I/O.

Operator dialogue and control

XBT F operator dialogue terminals have preconfigured screens dedicated to process control which simplify loop operation and control. These screens show the controller front panels as well as trending views and monitoring views.

Presentation

TSX P57 2●3/2●23/3●3/3623/453/4823M processors and T PCX 57 ●●3M coprocessors can be used to configure 10, 15 or 20 continuous or semi-continuous process control channels.

The control functions of these processors are particularly suitable for:

- Sequential processing requiring auxiliary control functions such as packaging machines, surface treatment machines, presses, etc.
- Simple processes such as metal processing furnaces, ceramic furnaces, refrigeration units, etc.
- Feedback or mechanical control where sampling time is critical, eg torque control, speed control, etc.
- Premium processors have, amongst others, the following characteristics:
 - Each configurable control channel can be used to manage 1 to 3 loops depending on the type of loop chosen.
 - Process control processors can be inserted in the overall architecture of a site as the PLC can be integrated in various communication networks.
 - Calculations related to process control are performed in floating point mode, expressed as physical units.

Description : TSX P57 ●●3/●●23M processors, see page 1/15; TPCX 57 ●●3M coprocessors, see page 1/21.

Characteristics and performance, see page 4/17.

Functions

Control loops

Premium processors can be used to set up 10 to 20 control channels, each one adopting one of the following 5 loop profiles :

- Process loop: loop with a single controller.
- Controller with 3 simple loops: controller which can increase the capacity of the number of loops.
- Autoselective loop also known as secondary: comprises 2 loops in parallel with an output selection algorithm.
- Cascaded loop: comprises 2 dependent loops (the master loop output is the slave loop setpoint).
- Setpoint programmer: comprises a maximum of 6 compound profiles with a total of 48 segments.

Since the channels are independent, configuration of 10 channels can be used to obtain:

- 30 simple loops.
- 5 setpoint programmers, each one associated with 5 control loops.
- 2 setpoint programmers and 8 process loops.

The various loops are characterised by:

- Their different algorithms.
- 5 processing branches (process value, setpoint, Feed Forward, loop controller and output processing).
- Calculation functions (gain, filtering, square root, etc) defined using parameters.

Type of control loops

Predefined algorithms, whose parameters can be defined by the user, are shown below:

Process loop



Simple loop



Autoselective loop

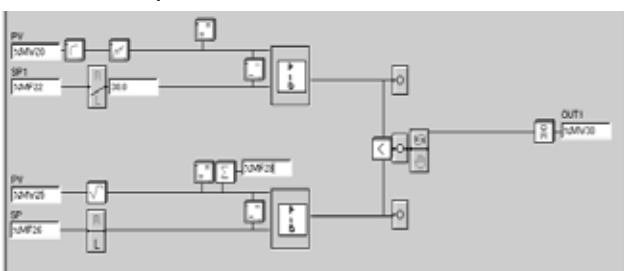

Cascaded loop

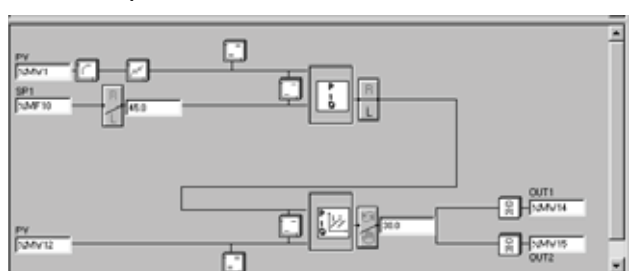

Processing branches

Parameter definition (choice of functions to be used) of control loop profiles enables the algorithm to be adapted to the process to be controlled.

Process value processing

Process value processing can be performed either in standard fashion or externally.

- Standard processing, the user has the following functions at his disposal: filtering, process value between limits, function generator with scaling, alarm management on threshold overrun, totalizer and simulation of the measured value.
- External processing is used to obtain, at the loop controller input, a process value, PV, which was processed outside the control loop. This solution is useful if measurement calculation of the process value requires specific or customised functions.

Setpoint processing

Depending on the type of loop chosen, it is possible to opt for one of the following 4 setpoints: ratio setpoint, selection setpoint, simple setpoint (remote with scaling) or setpoint programmer.

When using the controller with 3 single loops or the secondary loop (in an autoselective loop), only the simple setpoint and the setpoint programmer can be used.

Feed Forward processing

Feed Forward processing corrects a measurable disturbance as soon as it appears. This open loop processing anticipates the effect of the disturbance. It has the Leading function (phase lead/lag).

Loop controller and command processing

There are 6 different types of loop controller to choose from: autotuning PID, controller in discrete mode with 2 or 3 states, hot/cool controller (PID or autotuning model) or Split Range controller (PID or autotuning model).

Output processing

There are 3 types of output processing: analog output, servomotor output or PWM output. Whatever the type of output, the control calculated by the controller crosses a ramp limiter and a limiter where the lower and higher limits can be used to define the output variation range.

Setpoint programmer

The setpoint programmer offers a maximum of 6 profiles with a total of 48 segments. It is therefore possible to create a 48-segment programmer, six 8-segment programmers or one 24-segment programmer with one 16-segment programmer and one 8-segment programmer, etc.

- Each segment is configured as a ramp or dwell time. It is characterised by:
- The setpoint to be reached.
 - Duration of the segment or gradient of the segment (if a ramp).

A profile can be executed once, a certain number of times or continually looped back. Moreover, due to the concept of guaranteed dwell time, the time will only need to be downcounted if the process value is actually in the specified range.

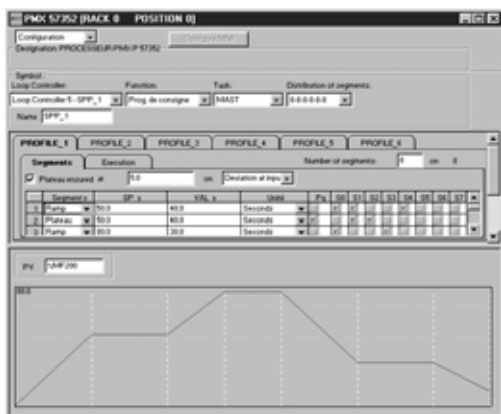

Debug functions

Adjustment and debugging of control loops is performed in a simple and user-friendly way using the loop configuration application-specific screen which, when online, can access the following functions:

- Display and animation of the loop algorithm diagram.
- Display of alarms linked to the process and channel faults.
- Simulation of input interface values: for example when they are not connected (process value, Feed Forward).
- Addition, removal or replacement of calculation functions in online mode.
- Modification of adjustment parameters for each function.
- Modification of loop controller operating modes and manual control.

With the controllers integrated in control loops, it is possible to use the autotuning function which calculates a set of adjustment parameters (Kp, Ti, Td or Ks, T1, T-delay) upon request.

Once the loop has been debugged, it is possible to save the current test values as the initial loop parameter values. Hence, on restarting the loop, it will contain the correct values.

Loop debugging

The debugging screen:

- Displays the values of variables linked to the loop dynamically.
- Shows the parameters chosen (or can even modify them).
- Displays alarms.

The menus enable manual control of the loop, autotuning, parameter backup, etc.

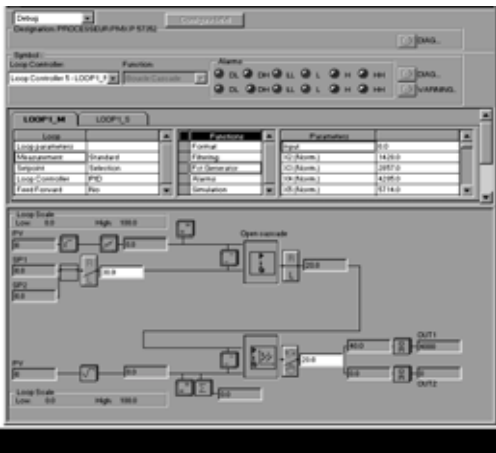

Loop debugging

Setpoint programmer debugging

Setpoint programmer channels have their own debugging screen which displays:

- The number of the current segment and the iteration number.
- Execution time of the current segment.
- Overall execution time.

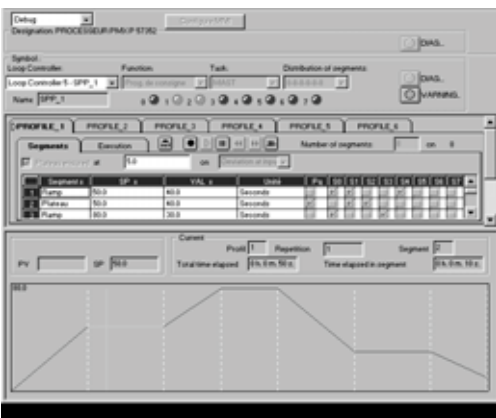

Setpoint programmer debugging

Runtime screens

The runtime screen tool available in PL7 Pro software integrates front panel views and trending views in its object library which can be used to adjust and operate control loops.

Front panel views and trending views

Predefined controller front panel views provide the user with the traditional appearance of controller front panels. The user only enters the variables used by the loop being dealt with in the various fields in this view.

Similarly, trending views display changes in loop parameters in graph form as well as useful operating information: operating mode, alarms, etc.

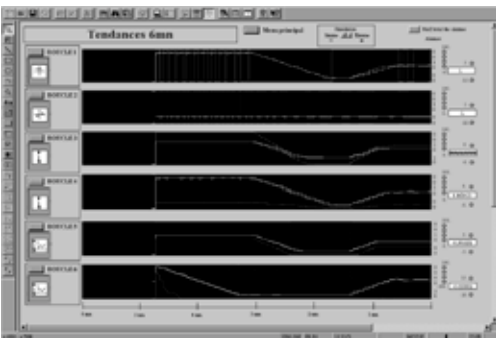

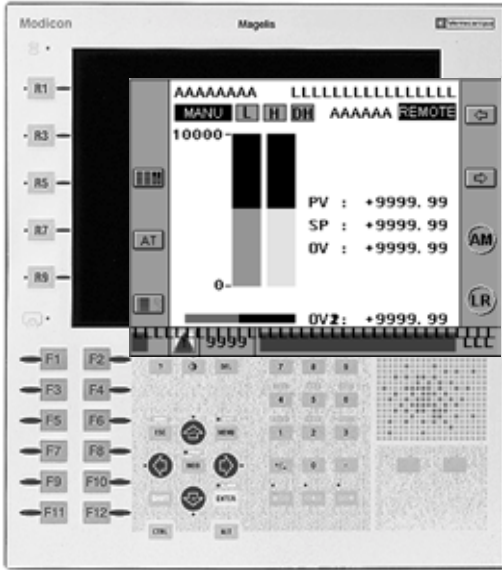

Control and operation

Tools integrated in PL7 software (loop debugging screens, runtime screens, etc) which are associated with XBT F Magelis graphic screen terminals offer screens dedicated to the control and operation of control loops.

Setup

These predefined screens offer runtime and control views.

As standard, PL7 Junior/Pro software contains the application developed with XBT L1003/L1004 development software, which comprises predefined runtime and control views. When using this dialogue application, animation of runtime and control views is automatic.

Presentation of views

Each control loop is associated with a certain number of views depending on the size of the Magelis terminal screen.

- With 5" screen terminals, the user has 7 views at his disposal:
 - monitoring view,
 - front panel (bar chart),
 - supervisory control view (trending),
 - adjustment view,
 - autotuning view,
 - setpoint programmer view,
 - alarm view.

With this type of terminal, it is possible to operate 8 loops.

- With 10" screen terminals, the user has 5 views at his disposal:
 - monitoring view,
 - front panel view integrating the display of the front panel, loop adjustment and autotuning,
 - supervisory control view,
 - setpoint programmer view,
 - alarm view.

With this type of terminal, it is possible to operate 16 loops.

All runtime pages are based on the same presentation module:

- An alarm zone is positioned at the bottom of the screen. It shows the last active alarm.
- Dynamic function keys execute one and only one function (access to the adjustment page, starting autotuning, navigation between the various pages, selecting a loop, etc.).

It is of course possible for the user to customise the screens to suit his requirements.

Presentation of views (continued)

Monitoring view



Monitoring view

This view is the control application entry point. It gives an overall view of all loops being operated on a single screen. For each loop, this view displays the loop name, measurement/setpoint deviation, operating mode, alarms and the execution of autotuning if applicable. The user can select a loop and access the front panel for example.

Front panel view

The front panel view uses the traditional format of controller front panels with the process value, the setpoint and the deviation between the 2. This view also integrates the operating mode as well as any alarms on the loop.

Function keys allow navigation between pages as well as control of loop operating modes.

Adjustment view

This view is used to adjust the loop controller. This function must be executed by qualified personnel. All the adjustment parameters are therefore write protected by a password. However, this view is always accessible in read mode.

The password applies to the whole man-machine interface.

Supervisory control view

This view displays the same information as the front panel view and also shows the 3 trends which are characteristic of the loop. The most recent trend history is recorded.

Function keys allow navigation between pages as well as control of the loop operating modes.

Setpoint programmer adjustment view

Two views specific to setpoint programmers are supplied. One is used to display the various profile names and to select one of them, the other is used to follow a given profile.

The second view is used to:

- Display the setpoint profile.
- Modify the segments, ramps and dwell time.
- Access the given profile.
- Track the process value.
- Control the profile.

4
1.1

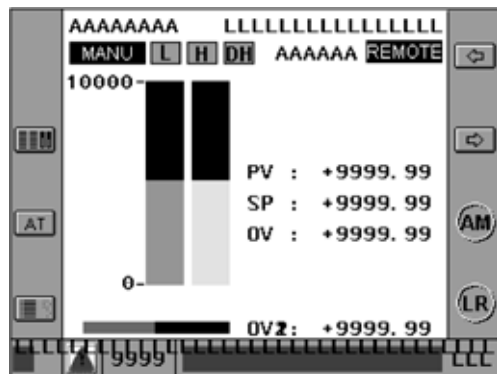

Front panel view

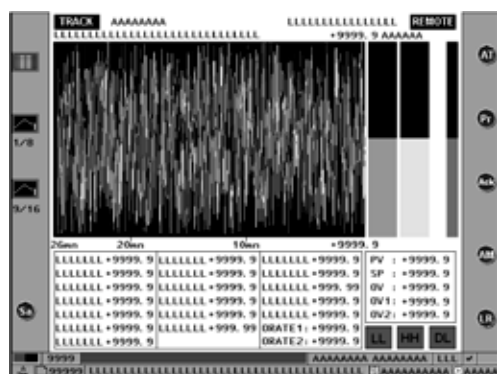

Adjustment view

Characteristics

The table below summarises the main characteristics of Premium processors and coprocessors presented in pages 1/16, 1/17 and 1/22.

Type of processor	TSX P57 2●3/2●23M TPCX 57 203M	TSX P57 3●3/3623M TPCX 57 353M	TSX P57 453/4823M
Number of racks	16 (1)	16 (1)	16 (1)
Number of discrete I/O (2)	1024	1024	2048
Number of analog channels (2)	80	128	256
Number of app.-specific channels(2)	24	32	64
Number of control channels	10	15	20
Process control functions	Process loop 3 simple loops Cascaded loop Autoselective loop Setpoint programmer		
Network connections	1	3	4
Fipio bus manager connection	1 (integrated with model TSX P57 253/2823M)	1 (integrated with model TSX/T PCX 57 353M)	1 (integrated)
Third-party bus connections	1	2	2
AS-Interbus bus connections	4	8	8
Memory	Internal RAM	K words 48/64 depending on model	64/80 or 80/96 depending on model (3)
	Capacity on PCMCIA card	K words 160	384
Memory occupation	K words 5 per type of loop + 0.5 per control channel	5 per type of loop + 0.5 per control channel	5 per type of loop + 0.5 per control channel

(1) Maximum number of TSX RKY racks. Using the TSX RKY 12EX rack (12 slots) is the same as using 2 racks with 4, 6 or 8 slots.

(2) The maximum numbers of discrete I/O, analog I/O and application-specific channels are cumulative. The number of remote I/O is not counted.

(3) The second value corresponds to the capacity of the integrated memory when the processor is fitted with a PCMCIA memory card.

Modicon Premium automation platform

Counter and electronic cam modules

Applications

Counter modules



Number of channels
Frequency per channel
Module cycle time

2 channels
40 kHz
5 ms

4 channels
40 kHz
10 ms

Counter/measurement input	Counting pulses = 24 V
	Incremental encoder
	Absolute encoder

Up to 40 kHz: - Proximity sensor type 2 - Mechanical contacts
Up to 40 kHz : - = 10...30 V - = 5 V RS 422 with zero marker
-

Reflex inputs/outputs

Per channel: - 3 inputs = 24 V: enable, preset and read - 1 input = 24 V line check, incremental encoder power supply - 2 reflex outputs = 24 V
--

Counting capacity

24 bits + sign (0 to + 16 777 215 points or ± 16 777 215 points)
--

Functions

Downcounting with preset input, upcounting with reset to zero input Up/down counting with preset input, configurable upcounter input: - 1 upcounter input/1 downcounter input - 1 up/down counter input and 1 direction input - Incremental encoder with phase-shifted signals
--

Processing

Inputs: counter enable, counter preset, read current value
Comparison: - Downcounting, to value 0 - Upcounting, 2 thresholds and 1 setpoint - Up/down counting, 2 thresholds and 2 setpoints
Reflex outputs: - Downcounting function, 1 passage through zero output - Upcounting function, 1 passage through setpoint value output - Up/down counting function, 2 user-definable outputs - Up/down counting function, 2 user-definable outputs

Events

User-definable activation of the event-triggered task (threshold crossing, setpoint crossing, preset or reset, enable, capture)

Connection

- 15-way SUB-D connectors (1 per counter channel, direct or TSX TAP S15 ●● accessory) - HE 10 connector for auxiliary I/O and power supply - Telefast 2 system (ABE 7CPA01, ABE 7H08R10/16R20)
--

Type of module

TSX CTY 2A

TSX CTY 4A

Page

4/25

4

1.2

Fast counter and measurement module

Electronic cam module



2 channels
500 kHz
1 ms

1 channel

Up to 1 MHz:
- Proximity sensor type 2
- Mechanical contacts

500 kHz in multiplication by 1, 250 kHz in multiplication by 4:
- \approx 10...30 V
- \approx 5 V RS 422 with zero marker

Power supply \approx 5 V ou \approx 10...30 V:
- SSI absolute encoder up to 25 bits
- Parallel absolute encoder up to 24 bits (with Telefast ABE 7CPA11 sub-base)

Per channel :
- 2 inputs \approx 24 V : preset and read
- 1 enable input or \approx 24 V output, configurable
- 2 reflex outputs \approx 24 V
- 1 programmable frequency output 24 V
- 1 encoder power supply input \approx 5 V/24 V

- 3 proximity sensor compatible inputs 24 V type I
- 24 track outputs 24 V/0.5 A protected

24 bits + sign (0 to + 16 777 215, upcounting) or 24 bits + sign (- 16 777 215 to + 16 777 215, downcounting, up/down counting). Up to 25 bits for SSI absolute encoder

256 to 32 768 points per cycle and from 1 to 32 768 cycles,(absorbs play on reverse)

Up/down counting with preset input, configurable counter input:
- 1 upcounter input/1 downcounter input
- 1 up/down counter input and 1 direction input
- Incremental encoder with phase-shifted signals
Measurement 2:
- SSI absolute encoder
- Parallel output absolute encoder with ABE 7CPA11 sub-base

Processing of 128 cams/32 tracks (of which 24 with direct output)
Output update cycle:
- 50 μ s for 16 cams
- 100 μ s for 64 cams
- 200 μ s for 128 cams
Two capture registers
Control/recalibration of axis slip

Inputs: counter enable, counter preset, read current value
Comparison:
2 thresholds

Cam profiles: 3 basic types (position, monostable, brake)
Associated functions:
- Elimination of axis backlash, position recalibration
- Measurement capture
- Switching feedforward
- Parts counter

Reflex outputs:
2 user-definable outputs
Speed monitoring
Special functions

User-definable activation of the event-triggered task (crossing of thresholds or modulo value, preset, enable, capture)

User-definable activation of the event-triggered task (cams, track, adjustment, read, etc.)

- 15 way SUB-D connectors (1 per counter channel, direct or TSX TAP S15 accessory)
- HE 10 connector for reflex I/O and power supply
- Telefast 2 system (ABE 7CPA01, ABE 7H16R20, ABE 7CPA11)

TSX CTY 2C

TSX CCY 1128

4/29

4/32

Modicon Premium automation platform

Premium motion control modules

Applications

Motion control modules for stepper motor

Motion control modules for servomotors
Compatible with:
- Lexium MHDA servodrives with analog setpoint
- Altivar ATV 38/58/68 variable speed drives



Number of axes
Frequency per axis

1 axis
187 kHz

2 axes
2 axes
Counter: 500 kHz with incremental encoder

Counter input

Per axis:
Translator inputs \approx 5 V, negative logic (translator loss of step checks)

Per axis:
Incremental encoder \approx 5 V, RS 422/RS 485 or Totem pole
SSI serial absolute encoder 16 to 25 bits \approx 10...30 V
Parallel output absolute encoder 16 to 24 bits \approx 5/10/30 V with Telefast 2 conversion sub-base (ABE 7CPA11)

Control outputs

Per axis:
RS 422 translator outputs, TTL 5 V compatible (+/- pulses, boost, enable, reset loss of step check)

Per axis:
1 analog output \pm 10 V, 13 bits + sign,

Auxiliary input/output

Per axis:
6 discrete inputs \approx 24 V
1 output \approx 24 V (brake control)

Per axis:
4 discrete I/O \approx 24 V (homing cam, event, recalibration, 1 input/1 output for servodrive control 1 reflex output \approx 24 V

Counter capacity

24 bits + sign (\pm 16 777 215 points)

Functions

Servo Control on individual linear axis

Processing

Open loop control of the position of a moving part on a limited linear axis according to motion control functions supplied by the PLC processor
Axis parameter setting, adjustment and debugging using PL7 Junior/Pro and Unity Pro software

Positioning of a moving part on an axis according
Axis parameter setting, adjustment and debugging using

Events

User-definable activation of the event-triggered task

Connection

- 15-way SUB-D connector for translator
- 20-way HE 10 connector for auxiliary I/O
- Telefast 2 system (ABE 7H16R20)

- 9 and 15-way SUB-D connectors for encoder input
- HE 10 connector for auxiliary inputs
- Telefast 2 system (ABE 7CPA01, ABE 7H16R20,
- Specific accessories (TSX TAP MAS)

Type of modules

TSX CFY 11 TSX CFY 21

TSX CAY 21 TSX CAY 41

Page

4/37

4/41

4

1.2

Motion control modules for servomotors
Compatible with Lexium MHDA servodrives equipped with optional card SERCOS



2 axes

4 axes

3 axes

8 axes

16 axes

Acquisition: 200 kHz with SSI serial absolute encoder or parallel output

SERCOS ring: 4 M bauds

Per axis:
- Incremental encoder --- 5 V, RS 422/RS 485 or Totem pole,
- SSI serial absolute encoder 12 to 25 bits
Parallel output absolute encoder 12 to 24 bits --- 5/10/30 V with Telefast 2 conversion sub-base (ABE 7CPA11)

Per SERCOS digital link

servodrive setpoint

Per SERCOS digital link

emergency stop)

Per SERCOS digital link

Servo control on individual infinite axis
Follower axes (dynamic ratio)
Realtime correction of servodrive offset

Servo control on individual linear or infinite axis
Linear interpolation on 2 or 3 axes
Realtime correction of servodrive offset

Individual linear or infinite axis
Linear interpolation on 2 to 8 axes
Follower axes (6 slaves) by gearing or camming
Manual mode (JOG and INC) (1)
Special functions, see page 4/52

to motion control functions supplied by the Premium PLC processor

PL7 Junior/Pro and Unity Pro software (2)

Axis parameter setting, adjustment and debugging using PL7 Junior/Pro software

(direct or via TSX TAP S15●●), speed reference
ABE 7CPA11),

2 SMA type connectors for plastic (or glass) fiber optic cable

TSX CAY 22

TSX CAY 42

TSX CAY 33

TSX CSY 84

TSX CSY 164

4/56

(1) Function not available with Premium platform under Unity Pro software.
(2) The Unity Pro software is not compatible with the TSX CSY 164 module.

Presentation

Counting functions are required for counting parts or events, grouping objects, incoming or outgoing flow control, and measuring the length or the position of elements.

Premium PLCs perform these functions using TSX CTY 2A/4A counter modules which have a counting frequency of 40 kHz maximum. In a Premium PLC configuration, the number of TSX CTY counter modules is added to the number of other application-specific modules (communication, motion control and weighing). See pages 1/18 and 1/23. They can be disconnected while powered up. Counter modules are characterised by the number of channels :

- 2 channels with downcounting, upcounting and up/down counting functions for the TSX CTY 2A module,
- 4 channels with downcounting, upcounting and up/down counting functions for the TSX CTY 4A module.

The parameters of these functions are set by software configuration. The modules accept ± 5 V or ± 10 to 30 V solid state output sensors (incremental encoders, proximity sensors, photoelectric detectors) and mechanical contact output sensors (in this case the counting frequency is limited to 100 Hz).

Description

The front panel of TSX CTY 2A (2-channel) and TSX CTY 4A (4-channel) counter modules comprises:

- 1 One 15-way SUB-D type connector per channel for connecting:
 - Counting sensors or incremental encoder.
 - Sensor power supply.
 - Encoder supply feedback for checking it is correctly supplied.
- 2 One 20-way HE10 type connector for 2 channels for connecting on each channel:
 - Auxiliary inputs: preset, enable.
 - Reflex outputs.
 - Power supplies for auxiliary I/O and incremental encoders.
- 3 Rigid casing which:
 - Holds the electronic card.
 - Locates and locks the module in its slot...
- 4 Module diagnostic LEDs:
 - Module diagnostics:
 - Green RUN LED: module operating,
 - Red ERR LED: internal fault, module failure,
 - Red I/O LED: external fault.
 - Channel diagnostics:
 - Green CH● LED: channel diagnostics available.

4

1.2

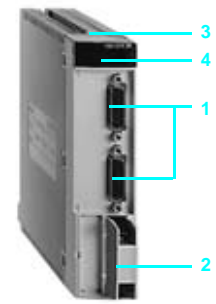

TSX CTY 2A

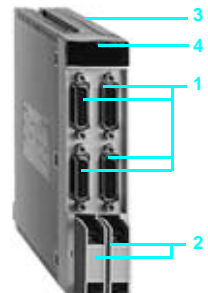

TSX CTY 4A

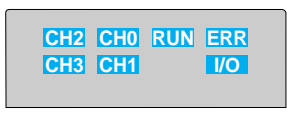

Operation block diagram

Block diagram of a channel

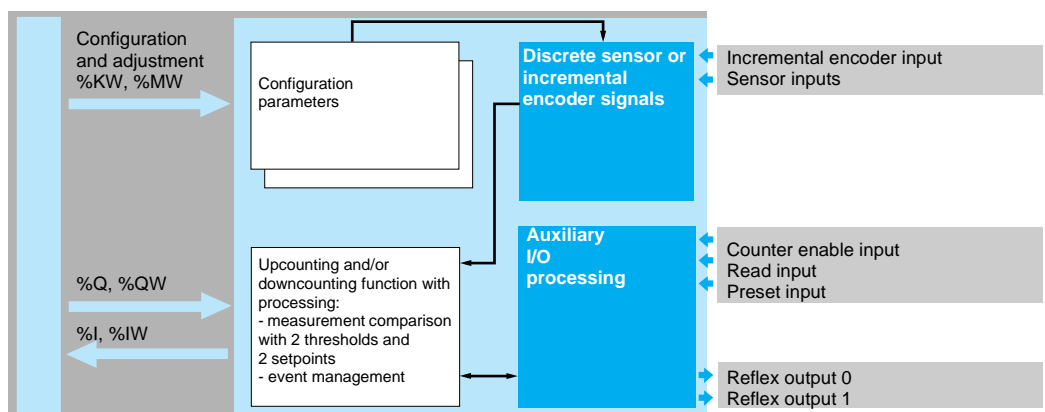

Counter modules are set up using PL7 Junior/Pro software (see page 6/7).

Electrical characteristics

Type of modules		TSX CTY 2A	TSX CTY 4A
Modularity		2 channels	4 channels
Frequency on counter inputs	kHz	40 maxi	40 maxi
Consumption	mA	see page 8/4	see page 8/4
Dissipated power	W	4.5 typical (6 maxi)	8 typical (11.5 maxi)
Sensor power supply check		yes	yes
Module cycle time	ms	5	10
Event processing response time	ms	Acceptance of event-triggered input (enable/read/preset) and positioning of: - reflex output on TSX CTY 2A/4A: 1 ms - discrete module output; TSX DSY 8T22: 2.1 ms; TSX DSY 32T2K: 3.2 ms	

Input characteristics

Type of input			Counter inputs (IA/IB/IZ)		Auxiliary inputs (preset, enable, read)	
Nominal values	Voltage	V	5	24	24	
	Current	mA	18	18	7	
Limit values	Voltage	V	≤ 5.5	19...30 (up to 34 V possible, limit 1 hr per 24 hr period)	19...30 (up to 34 V possible, limit 1 hr per 24 hr period)	
	At state 1	Voltage	V	≥ 2.4	≥ 11	
		Current	mA	> 3.7 (for U = 2.4 V)	> 6 (for U = 11 V)	> 6 (for U = 11 V)
	At state 0	Voltage	V	≤ 1.2	≤ 5	≤ 5
		Current	mA	< 1 (for U = 1.2 V)	< 2 (for U = 5 V)	< 2 (for U = 5 V)
Logic			Positive	Positive	Positive	
Sensor voltage check response time						
	At loss of 24 V	ms	–	–	< 2.5	
	At return of 24 V	ms	ms	–	–	
Input impedance	For nominal U	W	400	1400	3400	
	For U = 2.4 V (RS 422 compatibility)	W	> 270	–	–	
Response time			Maximum permissible frequency 40 kHz with incremental encoder Immunity 1.6 ms with mechanical contact		< 250 μs	
Type of input			Resistive	Resistive	Current sink	
IEC 1131 conformity			–	Type 2	Type 2	
2-wire proximity sensor compatibility			–	2-wire/3-wire	2-wire/3-wire	

Output characteristics

Type of output		Auxiliary outputs (2 par channel)	
Nominal voltage	V	--- 24	
Voltage limits	V	19...30 (up to 34 V possible, limit 1 hr per 24 hr period)	
Nominal current	mA	500	
Maximum voltage drop when ON	V	< 0.5	
Leakage current	mA	< 0.1	
Switching time	μs	< 250	
Electrostatic discharge time	s	L/R	
Switching frequency on inductive load	Hz	F < 0.6 / (LI ²)	
Compatibility with d.c. inputs		All positive logic inputs with input resistance < 15 kΩ	
IEC 1131 2 compatibility		yes	
Protections against overloads and short-circuits		Current limiter and thermal tripping (reactivated via program or automatically)	
Protection against channel overvoltages		Zener diode between outputs and + 24 V	
Protection against polarity inversions		Diode reverse-mounted on supply	

Connections

Examples of connecting counter inputs

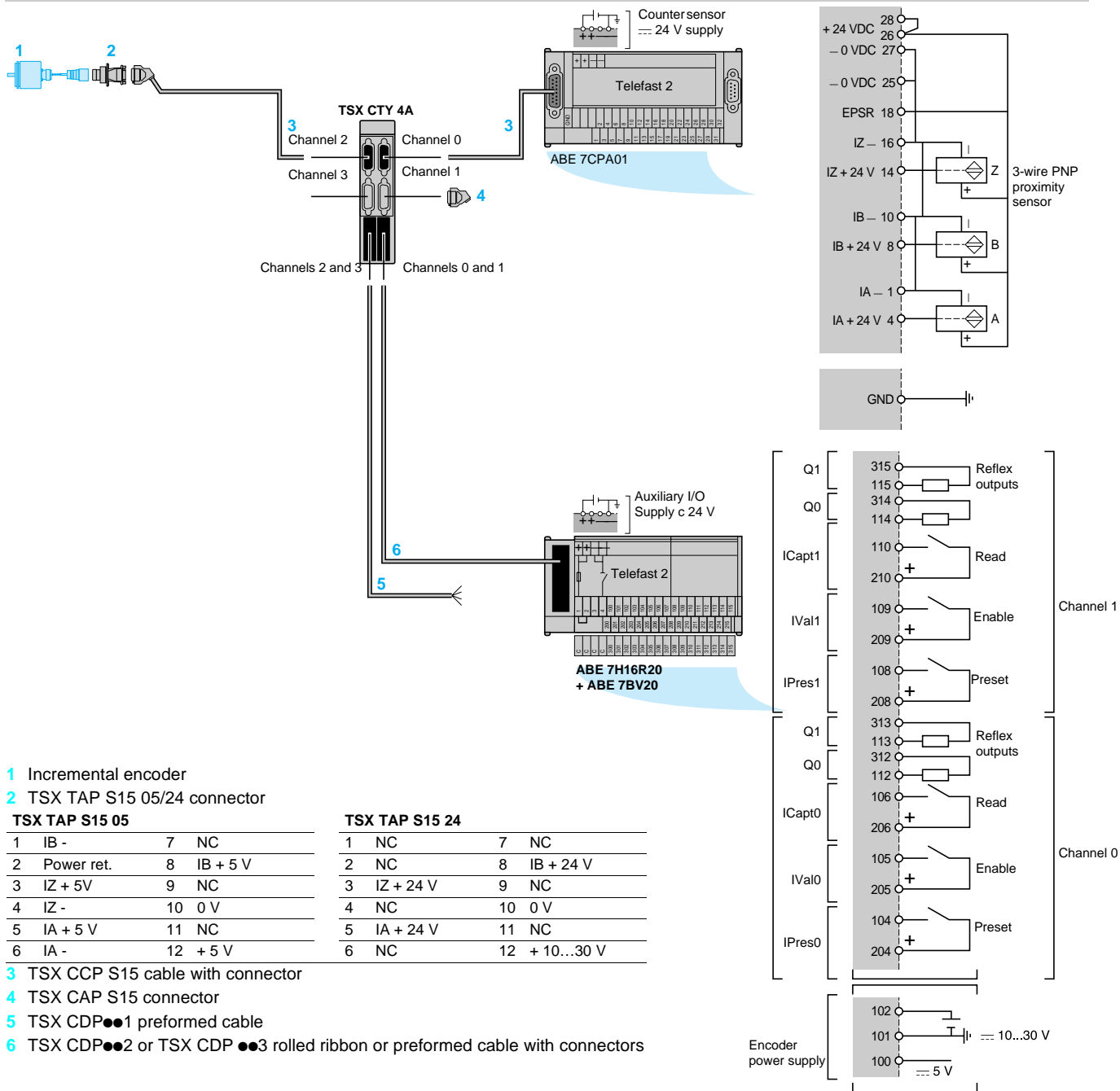

Dimensions

Connection interface for incremental encoder

TSX TAP S15 05/24

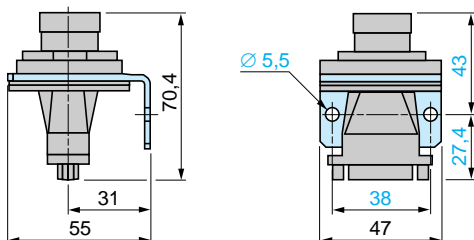

Mounting through enclosure (dust and damp proof)
 - cut-out Ø 37,
 - maximum panel thickness 5 mm.

Modicon Premium automation platform

TSX CTY 2A/4A counter modules



TSX CTY 2A TSX CTY 4A



ABE 7CPA01



ABE 7H16R20



TSX TAP S15 ●●

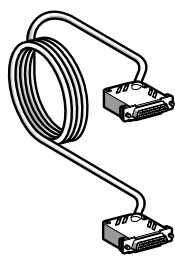

TSX CCP S15 ●●●

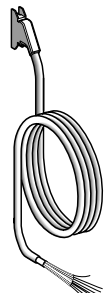

TSX CDP ●01

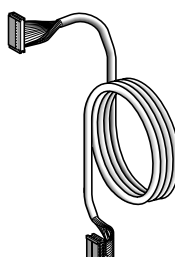

TSX CDP ●02

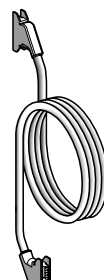

TSX CDP ●03

Counter modules

Type of input	Characteristics	Nb of channels	Reference (1)	Weight kg
2/3-wire prox.sensors PNP/NPN, \pm 24 V, Incremental encoder, \pm 5 V RS 422, \pm 10...30 V Totem Pole	Counting 40 kHz Cycle time 5 ms	2	TSX CTY 2A	0.320
	Counting 40 kHz Cycle time 10 ms	4	TSX CTY 4A	0.430

Connection accessories

Description	For connecting	Connector type on TSX CTY ●●	Rep.	Unit Reference	Weight kg
SUB-D connectors (sold in lots of 2)	Counter sensors or incremental encoder	SUB-D, 15-way	4	TSX CAP S15	0.050
Telefast 2 connection sub-bases	Counter sensors and \pm 24 V power supply	SUB-D, 15-way	—	ABE 7CPA01	0.300
	Auxiliary inputs, \pm 24 V power supply and \pm 5 V/10...30 V encoder power supply	HE 10, 20-way (for 2 channels)	—	ABE 7H16R20	0.300
Additional terminal block	20 shunted terminals (Sold in lots of 5) for ABE 7H16R20 sub-base		—	ABE 7BV20	0.030
Connection interfaces for incremental encoder	Encoder \pm 5 V RS 422	SUB-D, 15-way	2	TSX TAP S15 05	0.260
	Encoder \pm 10...30 V Totem Pole	SUB-D, 15-way	2	TSX TAP S15 24	0.260

Connecting cables

Description	From TSX CTY ●● module	To	Rep.	Length	Reference	Weight kg
Cables (cross-section 0.205 mm ²)	15-way SUB-D connector	ABE 7CPA01/ ABE CPA11 sub-bases or TSX TAP S15●● (15-way SUB-D connector)	3	0.5 m	TSX CCP S15 050	0.110
				1 m	TSX CCP S15 100	0.160
				2.5 m	TSX CCP S15	0.300
20-wire preformed cables (500 mA max.)	Auxiliary inputs, \pm 24 V power supply and \pm 5 V/10...30 V encoder power supply (HE 10, 20-way moulded connector)	Free end with colour-coded wires	5	3 m	TSX CDP 301	0.400
				5 m	TSX CDP 501	0.660
				10 m	TSX CDP 1001	1.210
Rolled ribbon cable (100 mA max.)	Auxiliary inputs, \pm 24 V power supply and \pm 5 V/10...30 V encoder power supply (HE 10, 20-way connector)	ABE 7H16R20 Telefast 2 sub-base (HE 10, 20-way connector)	6	1 m	TSX CDP 102	0.090
				2 m	TSX CDP 202	0.170
				3 m	TSX CDP 302	0.250
Connecting cables (500 mA max.)	Auxiliary inputs, \pm 24 V power supply and \pm 5 V/10...30 V encoder power supply (HE 10, 20-way connector)	ABE 7H16R20 Telefast 2 sub-base (HE 10, 20-way connector)	6	0.5 m	TSX CDP 053	0.085
				1 m	TSX CDP 103	0.150
				2 m	TSX CDP 203	0.280
				3 m	TSX CDP 303	0.410
				5 m	TSX CDP 503	0.670

(1) Product supplied with a bilingual Quick Reference Guide: English and French.

Presentation

The TSX CTY 2C measurement and counter module is used with fast machines requiring precise measurements with short cycle times and high input frequencies (timber machines, packing machines, etc).

The TSX CTY 2C measurement and counter module provides the standard functions (speed monitoring, reflex outputs, etc) enabling a simple position control function to be performed by the application program.

The TSX CTY 2C measurement and counter module also enables special functions to be managed.

Description

The front panel of a TSX CTY 2C measurement and counter module comprises:

- 1 One 15-way SUB-D connector per channel for connecting:
 - Counting sensors or incremental encoder,
 - SSI absolute encoder or parallel output encoder with ABE 7CPA11 sub-base,
 - Sensor power supply,
 - Encoder power supply feedback for checking it is correctly supplied.
- 2 One 20-way HE10 connector for connecting on each channel :
 - Auxiliary inputs: preset, enable and read,
 - Reflex outputs,
 - Programmable frequency output,
 - Power supplies for auxiliary I/O and encoders.
- 3 Rigid casing which:
 - Holds the electronic card,
 - Locates and locks the module in its slot...
- 4 Module diagnostic lamps:
 - Module diagnostic:
 - Green RUN: module operating.
 - Red ERR lamp: internal fault, module failure.
 - Red I/O lamp: external fault.
 - Channel diagnostic:
 - Green CH● lamp: channel diagnostics available.

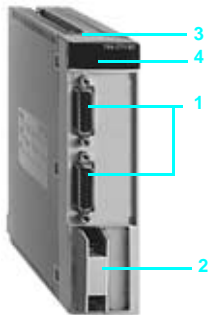

TSX CTY 2C



Operation block diagram

Block diagram of a channel:

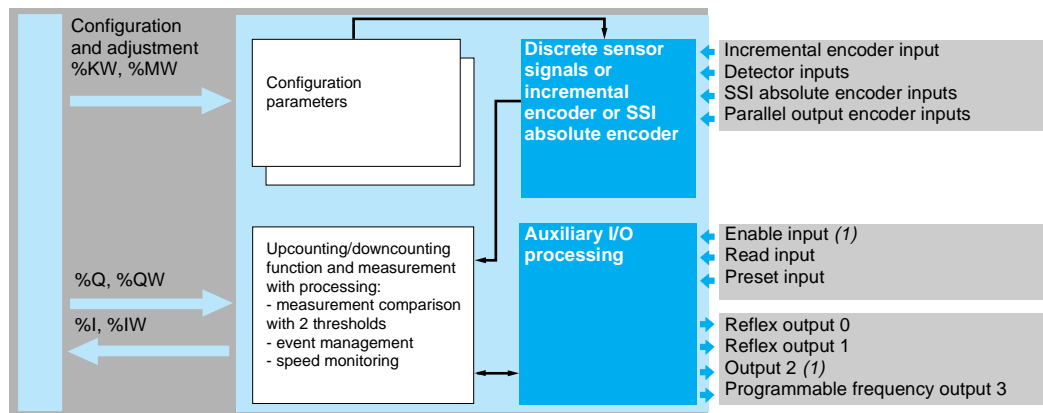

Counter modules are set up using PL7 Junior/Pro software (see page 6/7). This requires the use of TSX P/PCX 57●●2/3M processors and Atrium TPCX57 ●●2M/3M coprocessors.

(1) The enable input and output 2 cannot be used simultaneously.

Electrical characteristics

Type of module	TSX CTY 2C	
Modularity	2 channels	
Frequency on counter inputs	Counting: 1 MHz. With phase-shifted signal encoder: multiplication by 1: 500 kHz, multiplication by 4: 250 kHz	
Consumption	mA	see page 8/4
Dissipated power	W	7 typical (10 max.)
Sensor power supply check	Yes	
Module cycle time	ms	1 (for 2 channels)
Event processing response time	ms	Acceptance of event-triggered input (enable/read/preset) and positioning of - a reflex output: 1 ms - discrete output modules TSX DSY 8T22 : 2.1 ms ; TSX DSY 32T2K : 3.2 ms.

Input characteristics

Type of input			Counter inputs (IA/IB/IZ or SSI absolute encoder)	(IA/IB/IZ)	Auxiliary inputs (preset, enable, read)	
Nominal values	Voltage	V	5	24	24	
	Current	mA	18	16	8	
Limit values	Voltage	V	≤ 5.5	19...30 (up to 34 V possible, limited to 1 hr per 24 hr period)	19...30 (up to 34 V possible, limited to 1 hr per 24 hr period)	
	At state 1	Voltage	V	≥ 2.4	≥ 11	
		Current	mA	> 3.6 (for U = 2.4 V)	> 6 (for U = 11 V)	> 6 (for U = 11 V)
	At state 0	Voltage	V	≤ 1.2	≤ 5	≤ 5
	Current	mA	< 1 (for U = 1.2 V)	< 2 (for U = 5 V)	< 2 (for U = 5 V)	
Logic			Positive	Positive	Positive	
Sensor voltage check response time	At loss of 24 V	ms	–	–	< 2.5	
	At return of 24 V	ms	–	–	< 10	
Input impedance	For nominal U	W	400	1500	3400	
Input impedance for U = 2.4 V (RS 422 compatibility)			W	> 270	–	
Response time			μs	–	< 50	
Type of input			Resistive	Resistive	Current sink	
IEC 1131 conformity			–	Type 2	Type 2	
Proximity sensor compatibility			–	2-wire/3-wire	2-wire/3-wire	

Output characteristics

Type of output	Auxiliary outputs (2 per channel)	
Nominal voltage	V	± 24
Voltage limits	V	19...30 (up to 34 V possible, limited to 1 hr per 24 hr period)
Nominal current	mA	500
Maximum voltage drop when ON	V	< 0.5
Leakage current	mA	< 0.1
Switching time	μs	< 250
Electrostatic discharge time	s	L/R
Switching frequency on inductive load	Hz	$F < 0.6 / (LI^2)$
Compatibility with d.c. inputs	All positive logic inputs with input resistance < 15 kΩ	
IEC 1131 2 compatibility	Yes	
Protection against overloads and short-circuits	Current limiter and thermal tripping (reactivation via program or automatically)	
Protection against channel overvoltages	Zener diode between outputs and + 24 V	
Protection against polarity inversions	Diode reverse-mounted on supply	

Connections

Examples of connecting counter inputs

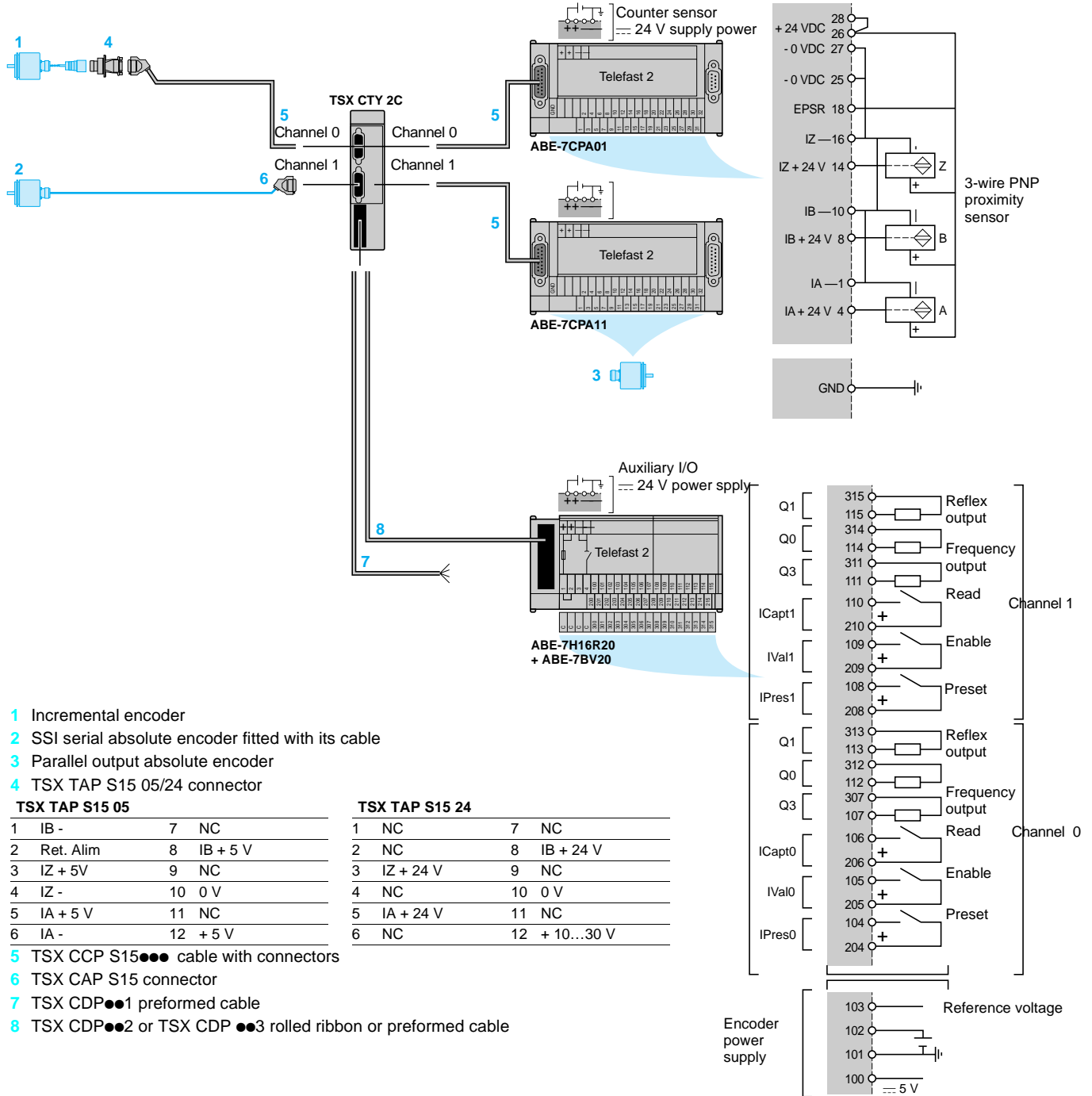

- 1 Incremental encoder
 - 2 SSI serial absolute encoder fitted with its cable
 - 3 Parallel output absolute encoder
 - 4 TSX TAP S15 05/24 connector
- | TSX TAP S15 05 | | | TSX TAP S15 24 | | |
|----------------|-----------|----|----------------|----|-------------|
| 1 | IB - | 7 | NC | 1 | NC |
| 2 | Ret. Alim | 8 | IB + 5 V | 2 | NC |
| 3 | IZ + 5V | 9 | NC | 3 | IZ + 24 V |
| 4 | IZ - | 10 | 0 V | 4 | NC |
| 5 | IA + 5 V | 11 | NC | 5 | IA + 24 V |
| 6 | IA - | 12 | + 5 V | 6 | NC |
| | | | | 7 | NC |
| | | | | 8 | IB + 24 V |
| | | | | 9 | NC |
| | | | | 10 | 0 V |
| | | | | 11 | NC |
| | | | | 12 | + 10...30 V |
- 5 TSX CCP S15 cable with connectors
 - 6 TSX CAP S15 connector
 - 7 TSX CDP preformed cable
 - 8 TSX CDP or TSX CDP rolled ribbon or preformed cable

Dimensions

TSX TAP S15 05/24s

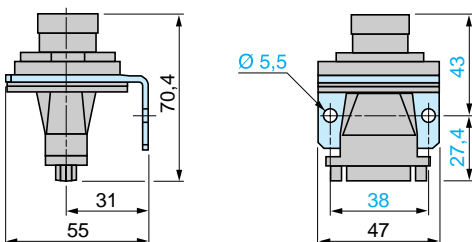

Mounting through enclosure (dust and damp proof):
 - cut-out \varnothing 37
 - maximum panel thickness 5 mm

Modicon Premium automation platform

TSX CTY 2C measurement and counter module



TSX CTY 2C



ABE 7CPA01



ABE 7H16R20



TSX TAP S15 ●●

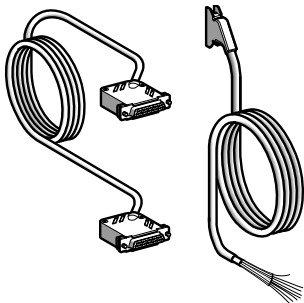

TSX CCP S15 ●●●

TSX CDP ●01

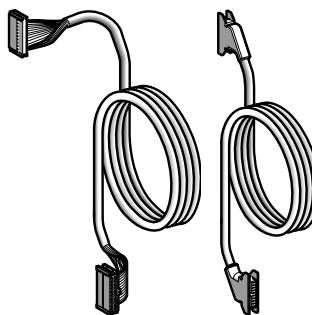

TSX CDP ●02

TSX CDP ●03

Measurement and counter module

Type of input	Characteristics	Rep.	Nb of channels	Reference (1)	Weight kg
2/3-wire prox.sensors PNP/NPN, \approx 24 V, Incremental encoder, \approx 5 V RS 422, \approx 10...30 V Totem Pole	Counting Cycle time 1 ms	—	2	TSX CTY 2C	0.340
SSI serial or parallel output absolute encoders with ABE 7CPA11 sub-base	Cycle time 1 ms	—	—	—	—

Connection accessories

Description	For connecting	Connector type on TSX CTY 2C	Rep.	Unit reference	Weight kg
SUB-D connector (sold in lots of 2)	Counter sensors or incremental encoder	SUB-D, 15-way	6	TSX CAP S15	0.050
Telefast 2 connection sub-base	Counter sensors and \approx 24 V power supply	SUB-D, 15-way	—	ABE 7CPA01	0.300
	Auxiliary inputs, supply \approx 24 V and encoder supply \approx 5 V/10...30 V	HE 10, 20-way (for 2 channels)	—	ABE 7H16R20	0.300
Additional terminal block	20 shunted terminals for ABE 7H16R20 sub-base	(Order in multiples of 5)	—	ABE 7BV20	0.300
Adaptor sub-base for TSX CTY 2C module (2)	Parallel output absolute encoders \approx 5 V, \approx 10...30 V	SUB-D, 15-way	—	ABE 7CPA11	0.300
Connection interfaces for incremental encoder	Encoder \approx 5 V RS 422	SUB-D, 15-way	4	TSX TAP S15 05	0.260
	Encoder \approx 10...30 V Totem Pole	SUB-D, 15-way	4	TSX TAP S15 24	0.260

Connecting cables

Description	From TSX CTY 2C module	To	Rep.	Length	Reference	Weight kg
Cables (cross-section 0.205 mm ²)	15-way, SUB-D connector	ABE 7CPA01/ ABE CPA11 sub-base or TSX TAP S15●● accessory (15-way, SUB-D connector)	5	0.5 m	TSX CCP S15 050	0.110
				1 m	TSX CCP S15 100	0.160
				2.5 m	TSX CCP S15	0.300
20-wire preformed cables (500 mA max.)	Auxiliary inputs supply \approx 24 V and encoder supply \approx 5 V/10...30 V (20-way, HE 10 moulded connector)	Free end with flying leads	7	3 m	TSX CCP 301	0.400
				5 m	TSX CDP 501	0.660
				10 ms	TSX CDP 1001	1.210
Rolled ribbon cables (100 mA max.)	Auxiliary inputs supply \approx 24 V and encoder supply \approx 5 V/10...30 V (20-way, HE 10 connector)	ABE 7H16R20 Telefast 2 sub-base (20-way, HE 10 connector)	8	1 m	TSX CDP 102	0.090
				2 m	TSX CDP 202	0.170
				3 m	TSX CDP 302	0.250
Connecting cables (500 mA max.)	Auxiliary inputs supply \approx 24 V and encoder supply \approx 5 V/10...30 V (20-way, HE 10 moulded connector)	ABE 7H16R20 Telefast 2 sub-base (20-way, HE 10 connector)	8	0.5 m	TSX CDP 053	0.085
				1 m	TSX CDP 103	0.150
				2 m	TSX CDP 203	0.280
				3 m	TSX CDP 303	0.410
				5 m	TSX CDP 503	0.670

(1) Product supplied with a bilingual Quick Reference Guide: English and French.

(2) Enables multiplexing of 2 absolute encoders on the same channel (up to 4 absolute encoders when using 2 ABE 7CPA11 adaptor sub-bases).

Modicon Premium automation platform

TSX CCY 1128 electronic cam module

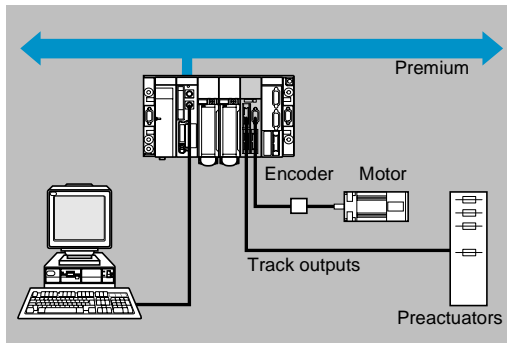

The TSX CCY 1128 module performs the “electronic cam” function for an animated axis of a rotary movement in a single direction, alternating, cyclical (with periodic arrival of parts for processing) or endless (with random arrival of parts for processing). The axis is managed by an incremental or absolute encoder.

The TSX CCY 1128 electronic cam module manages, independently, up to 128 cams which may be spread over a maximum of 32 tracks to which 24 discrete physical outputs and 8 logic outputs may be assigned.

Processing is structured in 4 groups of 8 tracks each, with groups 0 and 1 associated with the module connector 0 and groups 2 and 3 with connector 1.

The TSX CCY 1128 module can be used for the following functions: elimination of axis backlash, position recalibration, capturing measurements (part length, number of points per revolution, angle of arrival of parts, slip, etc), anticipation of switching, parts counter, generating events.

Like all application-specific modules, the TSX CCY 1128 module can be installed in any slot of a Premium PLC, except those dedicated to the power supply and the processor.

Description

The front panel of the TSX CCY 1128 electronic cam module comprises :

- 1 One 15-way SUB-D connector for connecting the incremental or absolute encoder.
 - 2 One 20-way HE 10 connector for connecting the track outputs on groups 0 and 1 (connector 0).
 - 3 One 20-way HE 10 connector for connecting the track outputs on groups 2 and 3 (connector 1).
 - 4 One 20-way HE 10 connector for connecting the auxiliary inputs and the encoder power supply.
- 5 Rigid casing for the following functions:
- Holding the electronic cards,
 - Attaching and locking the module in its slot.
- 6 Module diagnostic indicator lights:
- Module diagnostics :
 - green RUN indicator lamp: module on,
 - red ERR indicator lamp: internal fault, module defective,
 - red I/O indicator lamp: external or application fault.
 - Channel diagnostics:
 - green CH0 indicator lamps: channel diagnostics operative.

4

1.2

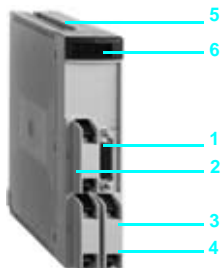

TSX CCY 1128



Operation

Block diagram of channel

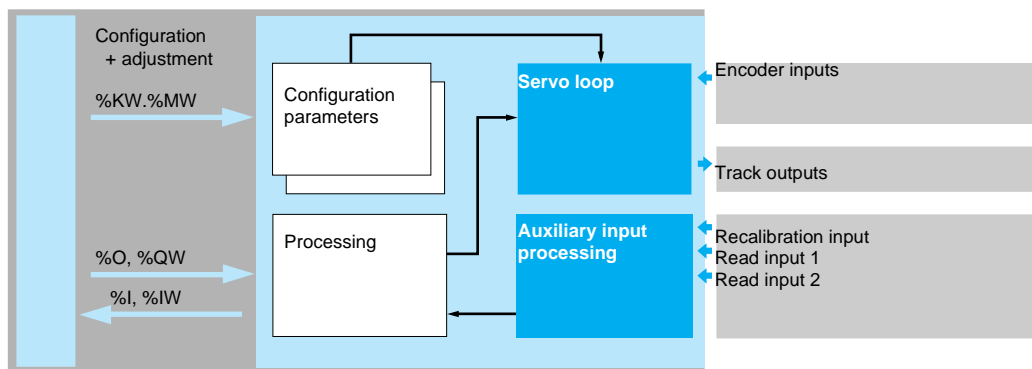

The electronic cam module is set up using PL7 Junior/Pro (version ≥ 3.4) and requires the use of processors with software version ≥ 3.3.

Operating characteristics	
Number of cams	128 position, monostable, brake type
Number of tracks	32 (24 directly associated with the 24 physical outputs, 8 logic)
Position encoder inputs	Incremental with RS 422/485 line emitter or Totem Pole output Absolute with SSI serial link Absolute with parallel outputs (via ABE 7CPA11 adaptor sub-base)
Controlled outputs	24 discrete outputs 24 V, 0.5 A
Associated functions	Elimination of axis backlash, position recalibration, measurement capture, switching feedforward, parts counter, generation of events

Electrical characteristics	
Modularity	1 axis
Max.frequency on encoder input	
SSI absolute encoder 8 to 25 bits	CLK transmission frequency kHz 200
Incremental encoder	x 1 kHz 500
	x 4 kHz 250
Current drawn by the module (typical)	On internal 5 V with internal module fan during operation mA 660
	On 24 V sensors/preactuators (auxiliary inputs and track outputs) mA 15
	On 10...30 V (use of an SSI encoder and single 24 V power supply) mA 11
Power dissipated in the module (typical)	W 7
Monitoring of sensor/preactuator power supplies	Yes
Output refresh cycle	µs 50 (up to 16 cams), 100 (up to 32 cams), 200 (up to 128 cams)

Input characteristics		Encoder inputs (IA/IB/IZ) with RS 422		with 10...30 V	Auxiliary inputs (recalibration, capture 0, capture 1)
Type of input		Differential inputs	Positive or negative	Positive	
Logic					
Nominal values	Voltage	V –	24	24	24
	Current	mA 10	15.5	8	
	Sensor power supply	V ≤ 5.5	19...30 (possible up to 34 V limited to 1 hr in 24 hrs)		
Limit values	At state 1	Voltage	> 3	≥ 11	≥ 11
		Current	mA > 5.8	> 5	> 3
	At state 0	Voltage	V ≤ - 3	< 5	< 5
		Current	mA ≤ - 5.8	< 2	< 1.5
Input impedance for nominal U		Ω –	1500	3000	
Type of input		Resistive	Resistive	Resistive	
Response time		µs –	–	< 100	
Conformity with IEC 1131		–	–	Type 1	
Compatibility w. 2-wire sensors		–	–	Yes (with 24 V)	
Compatibility w. 3-wire sensors		–	–	Yes (with 24 V)	

Output characteristics		Track outputs	
Type of output			
Nominal values	Voltage	V 24	
	Current	mA 500	
Limit values	Voltage	V 19...30 (possible up to 34 V limited to 1 hr in 24 hrs)	
Max.current	Per output for U _{nom} = 30 or 34 V	mA 600	
	Per connectorr	A ≤ 6	
	Per module	A ≤ 12	
Maximum power for tungsten filament lamp		W 10	
Switching frequency on an inductive load		Hz < 0.6/LI ²	
Electro. discharge time		s < L/R	
Preactuator voltage monitoring threshold	OK	V > 18	
	Fault	V < 14	
Compatibility with d.c. inputs		All positive logic inputs whose input resistance is < 15 kΩ	
Protection	Against overloads and short-circuits	By current limiter and thermal circuit-breaker	
	Against overvoltages on outputs	By Zener diode between the outputs and the + 24 V	
	Against polarity inversions	By reverse diode on the power supply	
Conformity with IEC 1131 2		Yes	

Modicon Premium automation platform

TSX CCY 1128 electronic cam module



TSX CCY 1128



TSX TAP S15



ABE 7CPA11



ABE 7H16R20

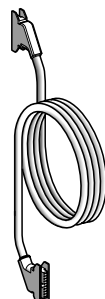

TSX CDP 003

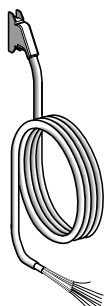

TSX CDP 001



TSX CCP S15

Electronic cam module

Type of output	Characteristics	Nb of axes	Reference (1)	Weight kg
Incremental encoder Supplied with 5 V or 10...30 V, with RS 422/485, or 5 V Totem Pôle outputs (2)	500 kHz counting w. incremental encoder	1	TSX CCY 1128	0.480
Absolute encoder RS 485 serial or parallel (3)	Acquisition 200 kHz with serial absolute encoder			

Connection accessories

Description	For connection of	Type of connectors on TSX CCY 1128	Ref. (4)	Unit reference	Weight kg
SUB-D connector (sold in lots of 2)	SSI absolute/incremental encoder	15-way SUB-D	4	TSX CAP S15	0.050
Connection interfaces for incremental encoder	5 V RS 422/RS 485 encoder	15-way SUB-D	6	TSX TAP S15 05	0.260
	10...30 V Totem Pôle	15-way SUB-D	6	TSX TAP S15 24	0.260
Telefast 2 connection sub-base	Auxiliary inputs, 5...24 V encoder power supply	20-way HE 10 (1 per module)	—	ABE 7H16R20	0.300
	Track outputs	20-way HE 10 (1 per 2 groups)	—	ABE 7H16R20	0.300
Adaptor sub-base	Absolute encoder with parallel outputs (16 to 24 bits) 5 V, 10...30 V	15-way SUB-D	—	ABE 7CPA11	0.300

Connection cables

Description	From	To	Ref. (4)	Length	Unit reference	Weight kg
Cables with connectors	TSX CCY 1128 module 15-way SUB-D connector	TSX TAP S15 connector interface or ABE 7CPA11 adaptor sub-base (15-way SUB-D connector)	5	0.5 m	TSX CCP S15 050	0.110
				1 m	TSX CCP S15 100	0.160
				2.5 m	TSX CCP S15	0.220
Connection cables (500 mA max.)	TSX CCY 1128 module 20-way insulated HE 10 connector	ABE 7H16R20 sub-base (20-way HE 10 connector)	7. 9	0.5	TSX CDP 053	0.085
				1	TSX CDP 103	0.150
				2	TSX CDP 203	0.280
				3	TSX CDP 303	0.410
				5	TSX CDP 503	0.670
Preformed cables with flying leads (500 mA max.)	TSX CCY 1128 module 20-way insulated HE 10 connector	Auxiliary inputs, power supply signals (free end)	8	3	TSX CDP 301	0.400
				5	TSX CDP 501	0.660

(1) Product supplied with a bilingual Quick Reference Guide: English and French.

(2) Totem Pole encoder with complementary Push/Pull outputs.

(3) Absolute encoders with parallel outputs with ABE 7CPA11 adaptor interface.

(4) Diagram references (see page 4/33).

Connections

Examples of encoder connections

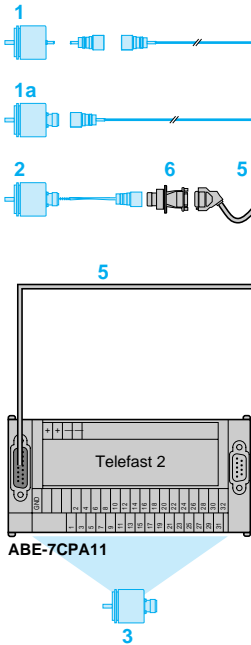

- 1 Incremental or absolute encoder
 - 1 Incremental or absolute encoder with 12-way DIN connector output
 - 2 5 V RS 422/485 Totem Pole incremental encoder
 - 3 Absolute encoder with parallel outputs
 - 4 TSX CAP S15 connector
 - 5 TSX CCP S15 cable with connectors
 - 6 TSX TAP S15 05/24 connector
- | TSX TAP S15 05 | | | TSX TAP S15 24 | | |
|----------------|----------|------------|----------------|-----------|----------------|
| 1 | IB- | 7 NC | 1 | NC | 7 NC |
| 2 | Sup.Ret. | 8 IB + 5 V | 2 | NC | 8 IB + 5 V |
| 3 | IZ + 5 V | 9 NC | 3 | IZ + 24 V | 9 NC |
| 4 | IZ - | 10 0 V | 4 | NC | 10 0 V |
| 5 | IA + 5 V | 11 NC | 5 | IA + 24 V | 11 NC |
| 6 | IA - | 12 + 5 V | 6 | NC | 12 + 10...30 V |
- 7 TSX CDP cable with connectors
 - 8 TTSX CDP preformed cable with flying leads
 - 9 TSX CDP cable with connectors

Examples of auxiliary input connections

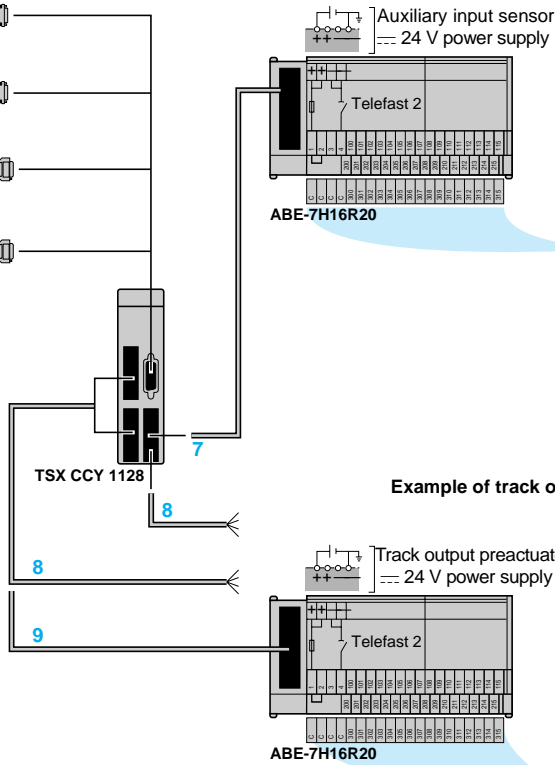

Example of track output preactuator connection

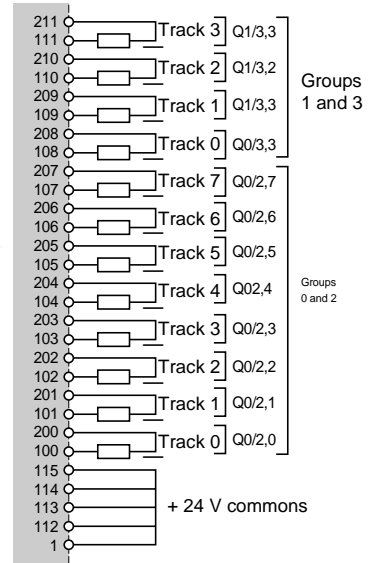
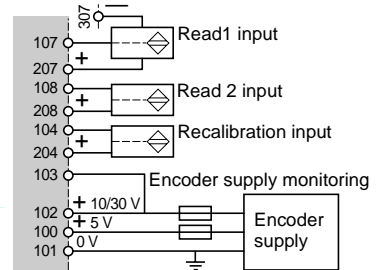

Dimensions

Connection interface for TSX TAP S15 05/24 incremental encoder

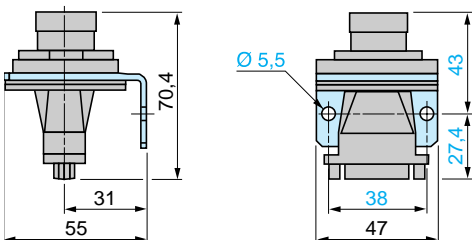

Enclosure feedthrough mounting (dust and damp proof)
 - cut-out Ø 37,
 - maximum panel thickness 5 mm.

Presentation

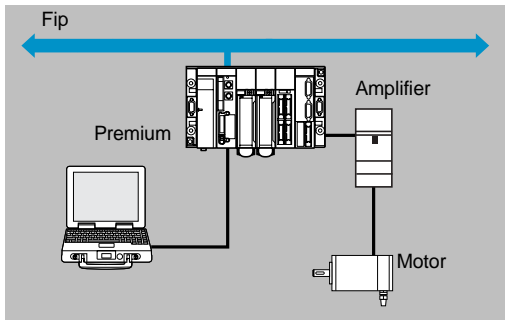

The TSX CFY 11/21 stepper motor axis control range is intended for machines which simultaneously require motion control by stepper motor associated with sequential control by programmable controller.

The TSX CFY 11 module controls, via an amplifier for stepper motor, 1 axis (channel 0). The TSX CFY 21 module controls 2 axes (channels 0 and 1). They accept amplifiers with:

- RS 422 or TTL 5 V inputs (negative logic).
- RS 422 or \bar{C} 5 V NPN open collector outputs.

In a Premium PLC configuration, the number of TSX CFY motion control modules should be added to the other application-specific modules (communication, counting, axis control and weighing).

Description

The front panel of TSX CFY 11/21 stepper control modules comprises:

- 1 One 15-way SUB-D connector per channel for connecting:
 - Amplifier inputs.
 - Amplifier outputs.
 - Amplifier input power supply.
- 2 One 20-way HE 10 connector for connecting:
 - Auxiliary inputs: per axis, homing cam, emergency stop, limit switches (+ and -), event, external stop.
 - Brake outputs (1 per axis).
 - External power supplies for sensors and preactuators.
- 3 Rigid casing which:
 - Holds the electronic card.
 - Locates and locks the module in its slot.
- 4 Module diagnostics lamps:
 - Module diagnostics:
 - green RUN lamp: module operating,
 - red ERR lamp: internal fault, module failure,
 - red I/O lamp: external fault.
 - Axis diagnostics:
 - 2 green CH● lamps: axis diagnostics available.

4

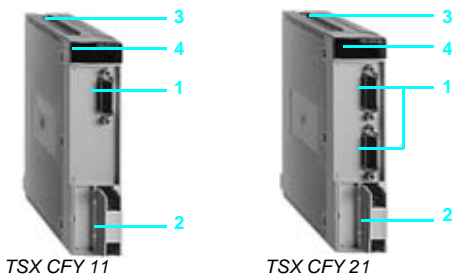

TSX CFY 11

TSX CFY 21

1.2

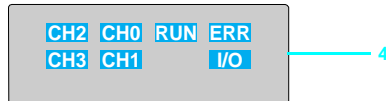

Operation block diagram

Operating characteristics are described on page 4/36. Stepper control modules are set up using PL7 Junior/Pro and Unity Pro software.

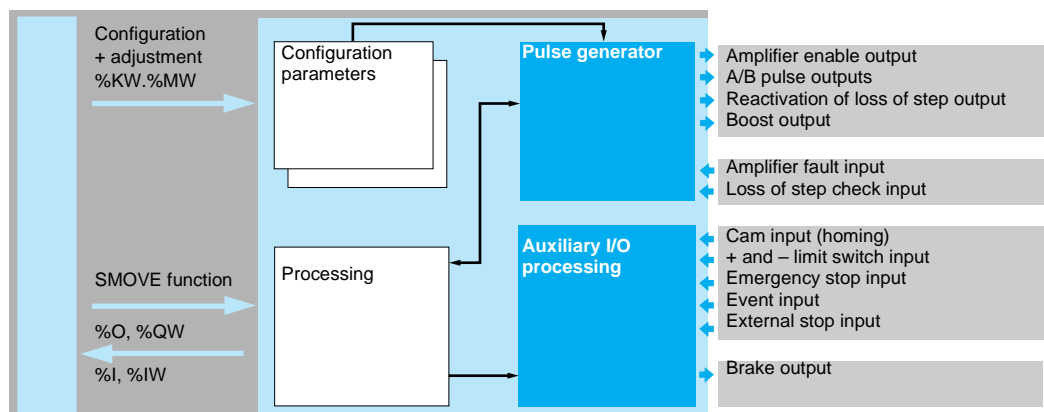

Electrical characteristics

Type of module			TSX CFY 11	TSX CFY 21
Modularity			1 axis	2 axes
Maximum pulse frequency			kHz 187.316	187.316
Consumption	--- 5 V	mA	510	650
	--- 24 V	mA	50	100
Power dissipated in the module Typical			W 3.8	5.6
Sensor power supply check			Yes	Yes

Input characteristics

Inputs			Amplifier inputs	Auxiliary inputs
Logic			Negative	Positive
Nominal values	Voltage	V	5	24
	Current	mA	4.5	7
Limit values	Voltage		V –	19...30 (up to 34 V possible, limited to 1 hr per 24 hr period)
	At state 1	Voltage	V < 2	≥ 11
		Current	mA –	> 6 (for U = 11 V)
	At state 0	Voltage	V > 3.6	< 5
		Current	mA –	< 2 (for U = 5 V)
	Input impedance for nominal U			kΩ –
Input immunity			μs Loss of step input: 15 to 30:	–
			μs –	Homing cam and event inputs: < 250
			ms Amplifier fault input: 3 to 16	Limit switch, emergency stop and external stop inputs: 3 to 10
Monitoring of external power supply for sensors and preactuators	Voltage for OK state		V –	> 18
	Voltage for fault state		V –	< 14
	Immunity OK → fault		ms –	> 1
	Immunity fault → OK		ms –	< 30
Type of input			Resistive	Current sink
IEC 1131 conformity			–	Type 2
Sensor compatibility			–	2-wire/3-wire

Output characteristics

Outputs			Amplifier outputs	Brake outputs (1 per axis)
Type of output			RS 422, TTL 5 V open collector NPN compatible	Open collector, PNP
Output differential voltage			V ± 2 (load resistance ≤ 100 Ω)	–
Short-circuit current			mA < 150	–
Permissible common mode voltage			V ≤ 7	–
Permissible differential voltage			V ≤ 12	–
Voltages	Nominal	V	–	--- 24
	Limit	V	–	19...30 (up to 34 V possible, limited to 1 hr per 24 hr period)
Currents	Nominal	mA	–	500
	Leakage	mA	–	< 0.3
	Maxi	mA	–	625 (for U = 30 or 34 V)
Maximum voltage drop when ON			V –	--- < 1
Switching time			μs –	< 250
Compatibility with DC inputs			–	All positive logic inputs with input resistance < 15 kΩ
IEC 1131-2 compliance			–	Yes
Protection against overloads and short-circuits			–	Via current limiter and thermal tripping (reactivated via program or automatically)
Short-circuit check on each channel			–	One signalling bit per channel
Protection against channel overvoltage			–	Zener diode between outputs and --- + 24 V
Protection against polarity inversions			–	By diode reverse-mounted on supply

Operating characteristics

Control		Pulse, frequency from 0 to 187 kHz
		+ and - outputs or +/- outputs and direction
Paths		Trapezoidal speed profile with minimum movement frequency
Operating modes	OFF	Module inactive
	DIR DRIVE	Module operating as pulse generator
	MAN	Motion controlled by operator: <input type="checkbox"/> visual control of movement <input type="checkbox"/> incremental movement
	AUTO	Movement sequence controlled by PLC program. Movements are described using a syntax similar to that of ISO language. Movements may be expressed in absolute or relative terms (in relation to either the current position or a home point). Operation is possible in "step-by-step" mode.
Checks	Environment	Amplifier, limits switches, Emergency stop
	Motion	Check correct execution by software position limits, loss of step
	Control	Check consistency of commands
	Parameters	Check validity of parameters
Optional commands		Boost, brake

Connections

TSX CFY 11/21 stepper control module connections

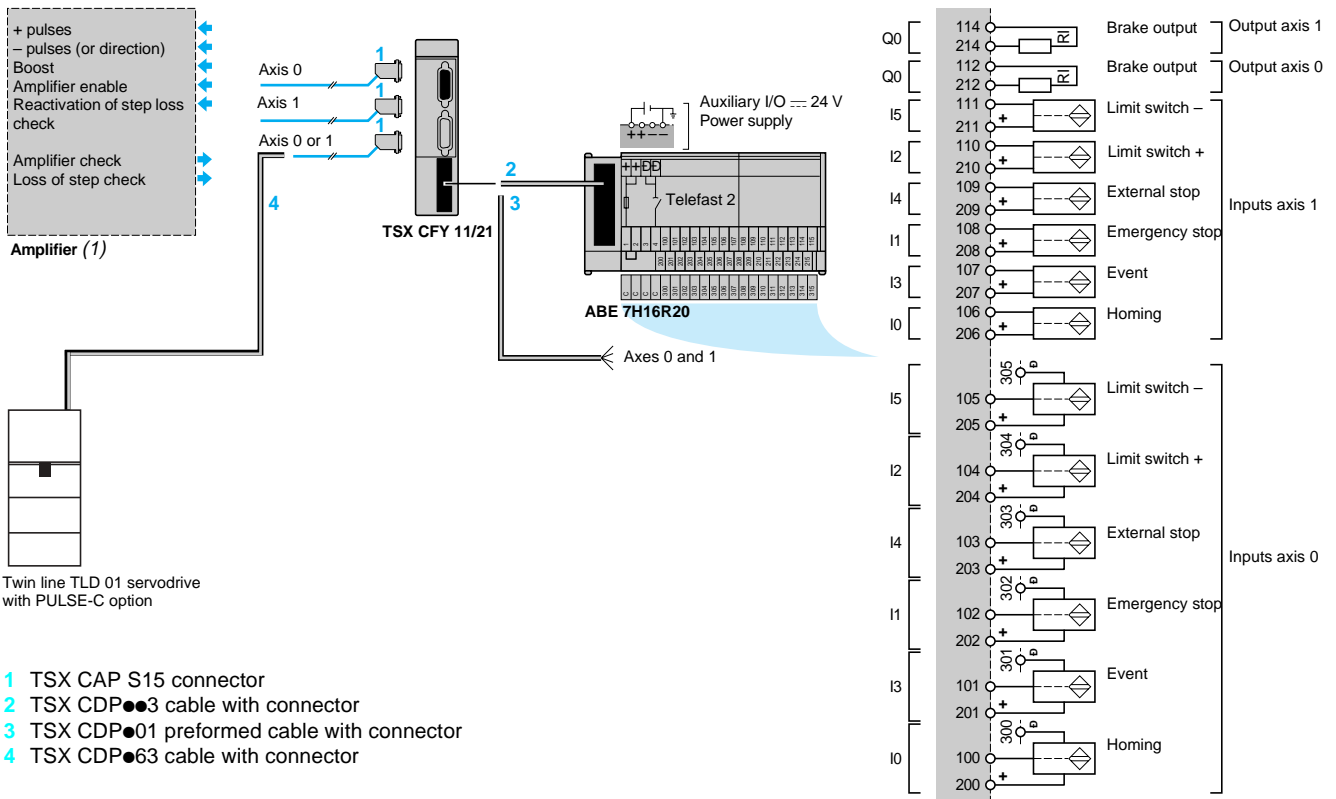

Modicon Premium automation platform

TSX CFY 11/21 modules for stepper motors

Motion control modules for stepper motors



TSX CFY 11



TSX CFY 21



ABE 7H16R20

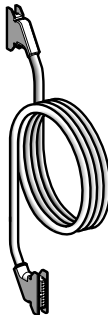

TSX CDP 003

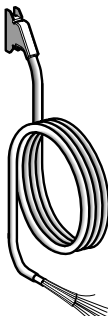

TSX CDP 001

Description	To control	Connections to connectors		No. of axes	Reference (1)	Weight kg
		SUB-D, 15-way	HE 10, 20-way			
Motion control modules for stepper motors	Amplifier with RS 422 I/O, \pm 5 V TTL and O \pm 5 V with open collector	Amplifier I/O	Auxiliary I/O, \pm 24 V power supply	1	TSX CFY 11	0.440
				2	TSX CFY 21	0.480

Connection accessories

Description	TSX CFY 01 connector	Type of connector on TSX CFY 01 module	N° (2)	Unit reference	Weight kg
SUB-D connectors	Amplifier	SUB-D, 15-way (1 per axis)	1	TSX CAP S15	0.050
		Sold in lots of 2			

Telefast 2 connection sub-base	Auxiliary I/O for axes 0/1, \pm 24 V power supply	HE 10, 20-way (1 for 2 axes)		ABE 7H16R20	0.300
--------------------------------	---	------------------------------	--	-------------	-------

Additional terminal block	20 shunted terminals for ABE 7H16R20 sub-bases	Order in multiples of 5		ABE 7BV20	0.030
---------------------------	--	-------------------------	--	-----------	-------

Connecting cables

Description	From module TSX CFY 01	To	N° (2)	Length	Reference	Weight kg
Cables (cross-section 0.324 mm ²)	20-way HE 10 connector	ABE 7H16R20 sub-base (20-way HE 10 molded connector)	2	0.5 m	TSX CDP 053	0.085
				1 m	TSX CDP 103	0.150
				2 m	TSX CDP 203	0.280
				3 m	TSX CDP 303	0.410
				5 m	TSX CDP 503	0.670
Preformed cables (cross-section 0.324 mm ²)	20-way HE 10 connector	Auxiliary I/O for axes 0/1, 24 V \pm power supply (flying leads at I/O end)	3	3 m	TSX CDP 301	0.400
				5 m	TSX CDP 501	0.660
				10 m	TSX CDP 1001	1.310

Cables for Twin Line TLD 01 amplifier	15-way SUB-D connector	Twin Line TLD 01 amplifier with PULSE-C option (15-way female SUB-D connector)	4	2 m	TSX CXP 263	–
				6 m	TSX CXP 663	–

(1) Includes a bilingual Quick Reference Guide: French and English.

(2) For key, see page 4/36.

Modicon Premium automation platform

TSX CAY modules for servomotors

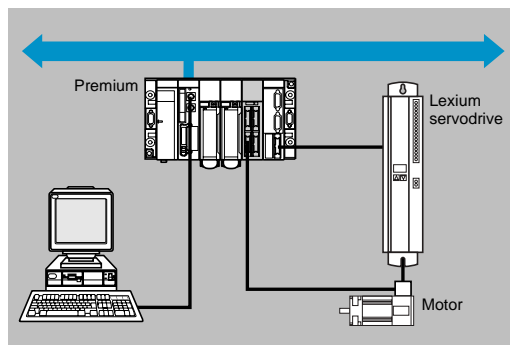

The TSX CAY ●● servo loop positioning axis control range is intended for machines which require simultaneous high performance motion control together with sequential control by programmable controller.

Depending on model:

- The TSX CAY 21/22 modules control 2 individual axes.
 - The TSX CAY 41/42 modules control up to 4 individual axes.
 - The TSX CAY 33 module control 3 interpolated linear axes.
- They can be used with ± 10 V analog input servodrives such as Lexium 17D/17D HP, and Twin Line TLD 13 servodrives.

TSX CAY ●● modules can be installed, like all application-specific modules, in any location on a Premium PLC rack.

Description

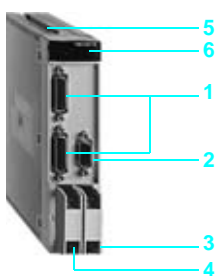

TSX CAY 21/22

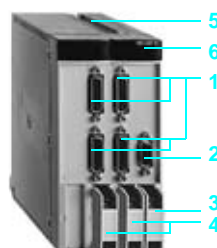

TSX CAY 41/42

The front panel of TSX CAY ●● axis control modules comprises:

- 1 One 15-way SUB-D connector per axis for connecting an incremental or absolute encoder.
- 2 One 9-way SUB-D connector for all axes for connecting:
 - 1 "speed reference" analog output for each axis.
- 3 One 20-way HE 10 connector for all axes for connecting:
 - Auxiliary inputs for servodrive control,
 - External power supply for servodrive I/O.
- 4 One 20-way HE 10 connector for 2 axes (0/1 or 2/3) for connecting:
 - Auxiliary inputs: homing cam, Emergency stop, event, recalibration.
 - High speed outputs.
 - External power supplies for sensors and preactuators.
- 5 Rigid casing which:
 - Holds the electronic card.
 - Locates and locks the module in its slot.
- 6 Module diagnostic lamps:
 - Module diagnostics:
 - green RUN lamp: module operating,
 - red ERR lamp: internal fault, module failure,
 - red I/O lamp: external fault.
 - Axis diagnostics:
 - green CH● lamps: axis diagnostics available.

Operation

Block diagram of an axis

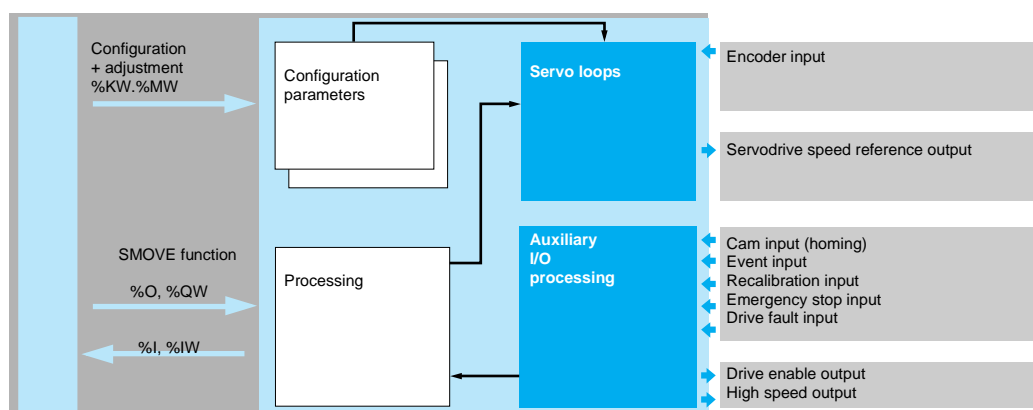

Axis control modules are set up using PL7 Junior/Pro or Unity Pro software (see page 4/48).

TSX CAY 22/42/33 modules require the use of TSX P57 ●●2M/3M/4M processors and Atrium TPCX57 ●●2M/3M coprocessors or TSX PCI 57●●4M.

Flying shear function of the TSX CAY 22 module requires the version ≥ 4.1 of PL7 Junior/Pro software (function not available with Unity Pro software, version 1.0).

Operating characteristics			TSX CAY 21/22	TSX CAY 41/42	TSX CAY 33
Type of module					
Servo loop			Proportional with feedforward and gain switching		
	Period	ms	2	4	
Paths	Speed profile		Trapezoidal or parabolic		
Resolution	Minimum		0.5 position unit per point		
	Maximum		1000 position units per point		
Length of axis	Minimum		TSX CAY 21: 32,000 points	TSX CAY 41: 32,000 points	TSX CAY 33: 256 points
			TSX CAY 22: 256 points	TSX CAY 42: 256 points	
	Maximum		32,000,000 points		
Speed	Minimum		54,000 points/min		
	Maximum		270,000 points/min		
Acceleration (from 0 to VMAX)	Minimum	s	10		
	Maximum	ms	8	16	
Operating modes	OFF		Measurement mode, inhibition of servo loop The module operates in current speed and position acquisition mode		
	DIR DRIVE		Direct drive mode, inhibition of servo loop The module operates in analog output mode only		
	MAN		Motion controlled by operator: <ul style="list-style-type: none"> ■ visual control of movement ■ incremental movement 		
	AUTO		Movement sequence controlled by PLC program. Movements are described using a syntax similar to that of ISO language. Movements can be expressed in absolute or relative terms (either in relation to current position, to a captured position or in relation to a home point). Operation is possible in "step by step" mode, by motion stop/start, by speed correction		
	FOLLOWER		The n axis of the module is governed by: <ul style="list-style-type: none"> ■ either the 0 axis of the same module ■ or a command profile transmitted by the application program 	-	
Checks	Environment		Encoder link, drive present, Emergency stop		
	Motion		Check correct execution of movements (following error, in-position band, software position limits)		
	Commands		Check consistency of commands		
	Parameters		Check validity of parameters		

Functions			TSX CAY 21	TSX CAY 22	TSX CAY 41	TSX CAY 42	TSX CAY 33
Type of module							
Linear interpolation, 2/3 axes			-	-	-	-	Yes
Limited axes			Yes	Yes	Yes	Yes	Yes
Infinite axes			-	Yes	-	Yes	Yes
Follower axes	Static ratio		Yes	-	Yes	-	-
	Dynamic ratio		-	Yes	-	Yes	-
Correction of servodrive offset			-	Yes	-	Yes	Yes
Flying shear	On position or on event with infinite master axis and linear slave axis		-	Yes (see page 4/38)	-	-	-

Electrical characteristics

Type of module		TSX CAY 21	TSX CAY 22	TSX CAY 41	TSX CAY 42	TSX CAY 33
Number of axes		2 axes	2 axes	4 axes	4 axes	3 axes
Maximum frequency at counter inputs						
SSI absolute encoder		16 to 25 bits	12 to 25 bits	16 to 25 bits	12 to 25 bits	12 to 25 bits
CLK transmission frequency	kHz	200				
Incremental encoder	x 1	kHz 500				
	x 4	kHz 250 kHz as input or 1 MHz as counter				
Consumption	≡ 5 V	mA 1100		1500		
	≡ 24 V	mA 15		30		
Current drawn by the module on the 10/30 V encoder at 24 V (24 V absolute encoder)	Typical	mA 11 (20 max)		22 (40 max)		
Power dissipated in the module	Typical	W 7.2 (11.5 max)		10 (17 max)		
Sensor power supply check		Yes		Yes		

Input characteristics

Type of input		Counter inputs ≡ 5 V (IA/IB/IZ)	Servodrive check inputs (1 per axis)	Auxiliary inputs (homing, event, recalibration, Emergency stop)
Logic		Positive	Positive	Positive
Nominal values	Voltage	V 5	24	24
	Current	mA 18	8	8
Limit values	Voltage	V ≤ 5.5	19...30 (up to 34 V possible, limited to 1 hr per 24 hr period)	19...30 (up to 34 V possible, limited to 1 hr per 24 hr period)
	At state 1			
	Voltage	V ≥ 2.4	≥ 11 (OK state)	≥ 11
	Current	mA > 3.7 (for U = 2.4 V)	> 3.5 (for U = 11 V)	> 6 (for U = 11 V)
	At state 0			
	Voltage	V ≤ 1.2	≤ 5 (fault state)	≤ 5
	Current	mA < 1 (for U = 1.2 V)	< 1.5 (for U = 5 V)	< 2 (for U = 5 V)
Voltage/encoder feedback check		Presence check	–	–
Input impedance for nominal U		Ω 270	3000	3000
Type of input		Resistive	Resistive	Current sink
IEC 1131 compliance		–	Type 1	Type 2
2-wire sensor compatibility		–	–	Yes (all prox. sens. 24 V)
3-wire sensor compatibility		–	–	Yes (all prox. sens. 24 V)

Output characteristics

Type of output		Analog outputs (1 per axis)	Drive enable (1 relay output per axis)	High speed outputs (1 per axis)
Range	V	± 10.24	–	–
Resolution		13 bits + sign	–	–
Value of LSB	mV	1.25	–	–
Nominal voltage	V	–	≡ 24	≡ 24
Voltage limit	V	–	5...30	19...30 (up to 34 V possible, limited to 1 hr per 24 hr period)
Current	mA	–	–	500 nominal
Maximum current	mA	1.5	200 (resistive load at 30 V)	625 (for U = 30 or 34 V)
Minimum permitted load		–	1 V/1 mA	–
Maximum voltage drop when ON	V	–	–	< 1
Leakage current	mA	–	–	< 0.3
Switching time		–	< 5 ms	< 500 μs
Compatibility with DC inputs		–	–	All positive logic inputs with input resistance < 15 kΩ
IEC 1131 compliance		–	–	Yes
Protections against overload and short-circuits		–	–	Current limiter and thermal tripping
Protection against channel overvoltage		–	–	Zener diode between outputs and + 24 V supply
Protection against polarity inversions		–	–	Reverse-mounted diode on supply

Modicon Premium automation platform

TSX CAY modules for servomotors

Motion control modules for servomotors



TSX CAY 20

Type of input	Characteristics	Functions	No. of axes (1)	Reference (2)	Weight kg
Incremental encoders = 5 V RS 422, = 10...30 V Totem Pole (3)	500 kHz counter with incremental encoder, Acquisition 200 kHz	Servo control on independent linear axis	2	TSX CAY 21	0.480
Absolute encoders RS 485 serial or parallel (4)	with serial absolute encoder	Servo control on independent linear or infinite axis Follower axes Realtime correction of servodrive offset Flying shear (5)	4	TSX CAY 41	0.610
		Servo control on independent linear or infinite axis Follower axes Realtime correction of servodrive offset	2	TSX CAY 22	0.480
		Servo control on linear or infinite axis Linear interpolation on 2 or 3 axes Realtime correction of servodrive offset	4	TSX CAY 42	0.610
			3	TSX CAY 33	0.610



TSX CAY 33

Connection accessories

Description	Connection	Type of connector on TSX CAY module	No. (6)	Reference	Weight kg
SUB-D connectors (lot of 2)	Incremental/SSI absolute encoder	SUB-D, 15-way (1 per axis)	4	TSX CAP S15	0.050
	Speed references	SUB-D, 9-way (1 per TSX CAY module)	7	TSX CAP S9	0.050



TSX CAY 40

Connection interface for incremental encoder	Incremental encoder = 5V RS 422/RS 485	SUB-D, 15-way (1 per axis)	6	TSX TAP S15 05	0.260
Splitter block	Speed references to servodrives	SUB-D, 9-way (1 per TSX CAY module)	–	TSX TAP MAS	0.590
Telefast 2 connection sub-bases	Speed references	SUB-D, 9-way (1 per TSX CAY module)	–	ABE 7CPA01	0.300



TSX TAP S15

	Auxiliary inputs, High speed outputs, I/O power supply = 24 V, encoder power supplies = 5/24 V	HE 10, 20-way (1 for 2 axes)	–	ABE 7H16R20	0.300
--	--	------------------------------	---	--------------------	-------



TSX TAP MAS

	Servodrive control signals, I/O = 24 V power supply	HE 10, 20-way (1 per TSX CAY module)	–	ABE 7H16R20	0.300
--	---	--------------------------------------	---	--------------------	-------

Adaptor sub-base	Parallel output absolute encoders (16 to 24 bits) = 5 V, = 10...30 V	SUB-D, 15-way	–	ABE 7CPA11	0.300
-------------------------	--	---------------	---	-------------------	-------



ABE 7CPA01

- (1) TSX CAY 41/42/43 modules, double format.
 (2) Product supplied with a bilingual Quick Reference Guide: English and French
 (3) Totem Pole encoder with complementary Push/Pull outputs.
 (4) Parallel output absolute encoders with ABE 7CPA11 adaptor interface.
 (5) Flying shear function available with TSX CAY 22 module. Requires version ≥ 4.1. of PL7 Junior/Pro software. Function not available with Unity Pro software.
 (6) For key, see pages 4/43 to 4/46.



ABE 7H16R20

Modicon Premium automation platform

TSX CAY modules for servomotors

Cables with SUB-D connectors

From	To	No. (1)	Length	Reference	Weight kg
TSX CAY●● module, 15-way SUB-D connector	TSX TAP S15 05 interface, or ABE 7CPA11 adaptor sub-base (15-way SUB-D connector)	5	0.5 m	TSX CCP S15 050	0.110
			1 m	TSX CCP S15 100	0.160
			2.5 m	TSX CCP S15	0.220

TSX CAY●● module, 9-way SUB-D connector (speed reference)	ABE 7CPA01 sub-base or TSX TAP MAS block (15-way SUB-D connector)	8	2.5 m	TSX CXP 213	0.270
			6 m	TSX CXP 613	0.580

Preformed cables with SUB-D connector fitted at 1 end and 1 free end (servodrive side)

TSX CAY ●● module, or TSX TAP MAS block	Speed reference for servodrive: Lexium MHDA, Twin Line TLD 13 or other (cross-section 0.205 mm ²)	9	6 m	TSX CDP 611	0.790
---	---	---	-----	-------------	-------

Connecting cables with HE 10 connector

TSX CAY ●● module, (20-way HE 10 connector)	ABE 7H16R20 sub-base (20-way HE 10 moulded connector) (500 mA max.)	10	0.5 m	TSX CDP 053	0.085
			1 m	TSX CDP 103	0.150
			2 m	TSX CDP 203	0.280
			3 m	TSX CDP 303	0.410
			5 m	TSX CDP 503	0.670

Preformed cables with HE 10 connector fitted at 1 end and 1 free end (servodrive side)

TSX CAY ●● module, (20-way HE 10 connector)	Auxiliary inputs, high speed outputs, control signals, power supplies (free end) 20-wire (500 mA max.)	11	3 m	TSX CDP 301	0.400
			5 m	TSX CDP 501	0.660

Connecting cables for Lexium MHDA servodrive

TSX CAY ●● module, 15 way SUB-D connector (encoder input)	Simulated incremental encoder feedback (9-way SUB-D connector)	12	2 m	TSX CXP 235	0.210
			6 m	TSX CXP 635	0.470
	Simulated absolute encoder feedback (9-way SUB-D connector)	13	2 m	TSX CXP 245	0.210
			6 m	TSX CXP 645	0.470

Connecting cables for Twin Line TLD 13 servodrive

TSX CAY ●● module, 15 way SUB-D connector (encoder input)	TLD 13 servodrive with ESIM1-C/2-C module Simulated incremental encoder feedback (15-way SUB-D connector)	14	2 m	TSX CXP 243 (1)	–
			6 m	TSX CXP 643 (1)	–
	TLD 13 servodrive with SSI-C module Simulated absolute encoder feedback (15-way SUB-D connector)	15	2 m	TSX CXP 273	–
			6 m	TSX CXP 673	–

Connecting cables for NUM MDLA servodrive (2)

TSX CAY ●● module, 15-way SUB-D connector (encoder input)	NUM MDLA modular speed drive (15-way, high density, SUB-D connector)	16	2.5 m	TSX CXP 233	0.220
			6 m	TSX CXP 633	0.470
TSX TAP MAS block, 9-way SUB-D connector	Speed reference on NUM MDLA modular speed drive (25-way SUB-D connector)	17	2.5 m	TSX CXP 223	0.340

Cables fitted with splitter block for Altivar AC drive

TSX CAY ●● module	Speed reference for ATV 38/58/58F AC drives for asynchronous motors	18	1 m	VY1 X411CA15	0.400
-------------------	---	----	-----	--------------	-------

(1) For key, see pages 4/43 to 4/46.

(2) See page 8/12.

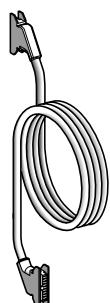

TSX CDP ●●3

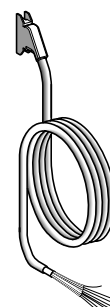

TSX CDP ●●01

Connections for TSX CAY modules

General connections

Examples of encoder connections

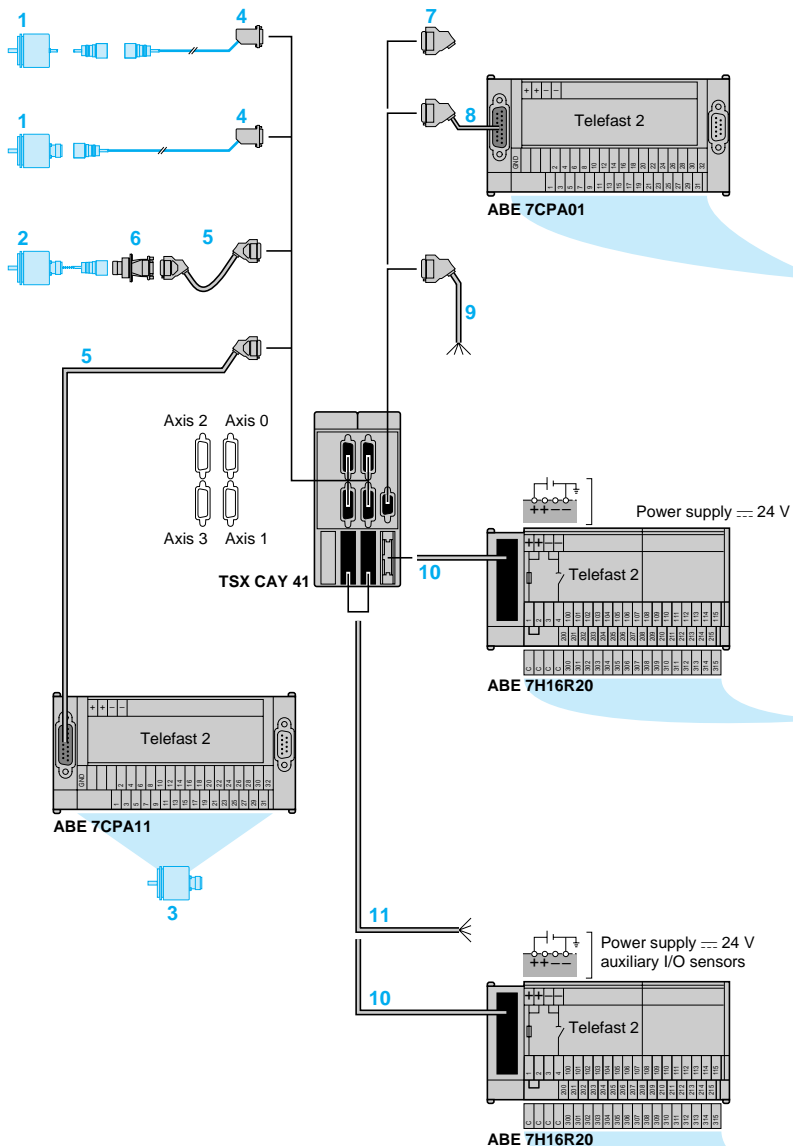

- 1 Incremental or absolute encoder
- 2 5 V RS 422 incremental encoder
- 3 Parallel output absolute encoder
- 4 TSX CAP S15 connector
- 5 TSX CCP S15 cable with connectors
- 6 TSX TAP S15 05 connector

1	IB-	7	NC
2	Sup. Ret.	8	IB + 5 V
3	IZ + 5 V	9	NC
4	IZ -	10	0 V
5	IA + 5 V	11	NC
6	IA -	12	+5 V

- 7 TSX CAP S9 connector
- 8 TSX CXP 213/613 cable with connector
- 9 TSX CDP 611 preformed cable with connector
- 10 TSX CDP cable with connector
- 11 TSX CDP preformed cable with connector

Examples of speed reference signal connections

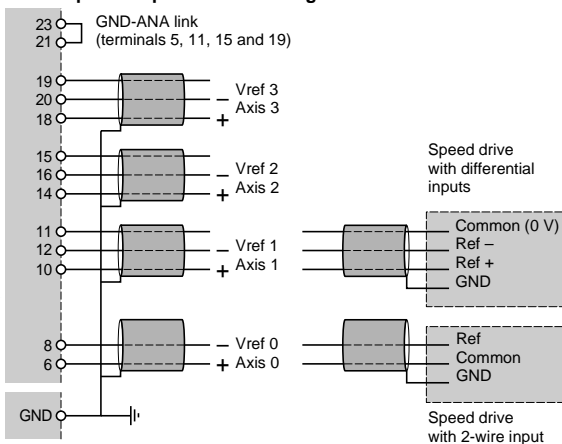

Example of speed drive connection (auxiliary I/O)

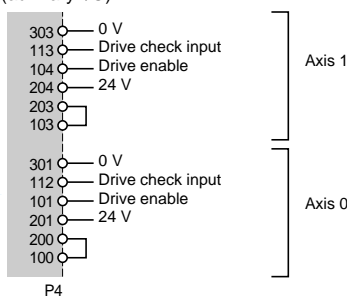

Example of auxiliary I/O connection

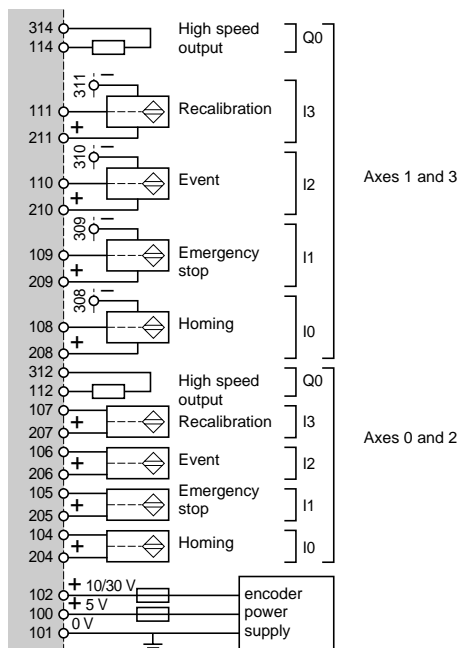

Connection example for Altivar ATV-58F speed drive (for asynchronous motors)

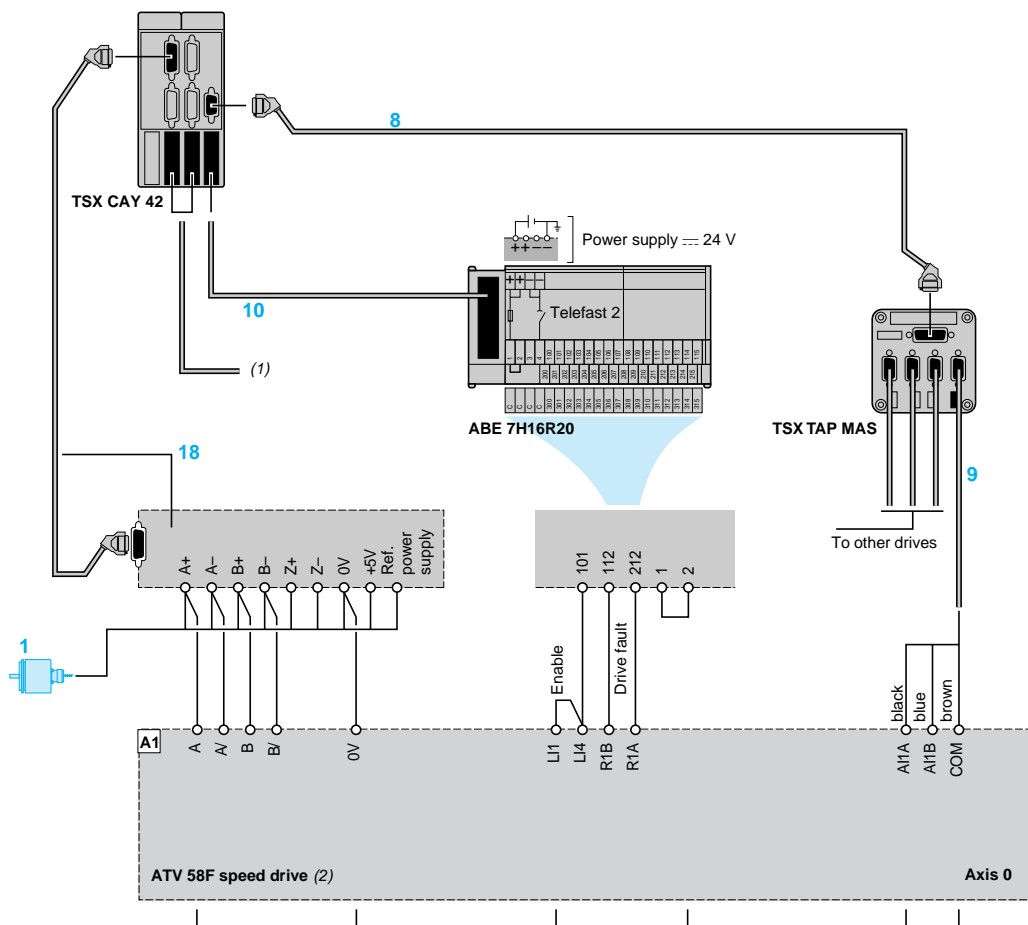

- 1 Incremental encoder
- 8 TSX CXP 213/613 cable with connector
- 9 TSX CDP 611 preformed cable with connector
- 10 TSX CDP●●3 cable with connector
- 18 VY1 X411CA15 cable with connector and adapter sub-base

(1) For auxiliary I/O connections (for example: Emergency stop, homing, etc), see the connections on page 4/43.

(2) The speed drive must be programmed as "Macro configuration General use". For other ATV 58F speed drive connections, please see our specialist catalog "Progressive starters and speed servodrives".

Connection example for NUM MDLA modular speed drives

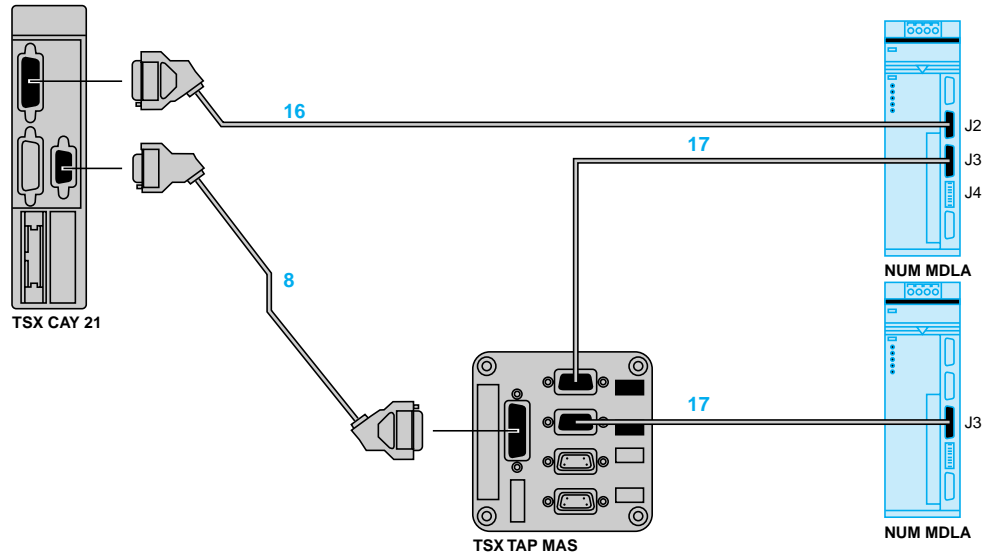

- 8 TSX CXP 213/613 cable with connector
- 16 TSX CXP 233/633 cable with connector
- 17 TSX CXP 223 cable with connector

Connection example for distribution of speed references for speed drives

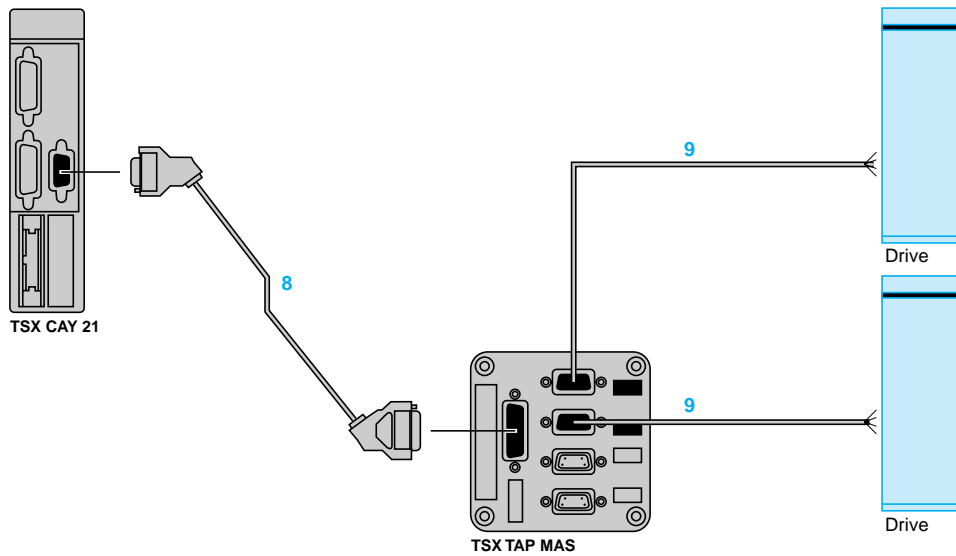

- 8 TSX CXP 213/613 cable with connector
- 9 TSX CDP 611 preformed cable with connector

4

1.2

Modicon Premium automation platform

TSX CAY modules for servomotors

Dimensions

TSX TAP S15 05 connection interface for incremental encoder

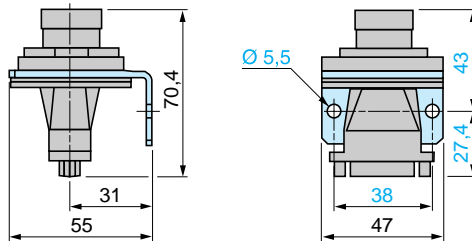

Mounting in enclosure feedthrough (dust and damp proof)

- Ø 37 cut-out,
- Panel thickness 5 mm maximum

TSX TAP MAS speed reference splitter block for speed drives

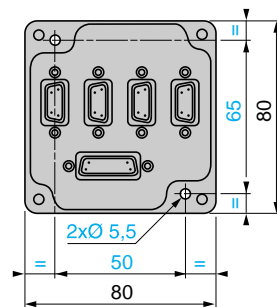

Mounting on DIN rail with LA9-DC9976 accessory.

TSX CAY/CFY module software setup

PL7 Junior/Pro or Unity Pro setup software provides:

- SMOVE and XMOVE motion control functions for programming movements. These functions can be used in Ladder language, Instruction list language or Structured Text language.
- Specialized screens for configuring, adjusting and debugging axes.

Programming movements

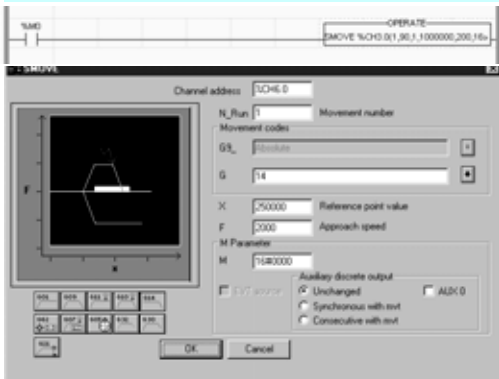

A movement on an independent axis is initiated by executing an SMOVE control function in the application program.

Example: go to the absolute position 10 000 000 μm, at a speed of 200 mm/min, without stopping.

A screen enables the assisted entry of parameters in the SMOVE function in an operation block.

The XMOVE command enables movement to be initialized on interpolated axes (TSX CAY 33 only).

4

Instruction codes

The characteristics of movements are described using a syntax similar to that for a numerical controller program block written in ISO language. TSX CAY and TSX CFY motion control modules use the following instructions:

Code and type of instruction	Individual axes (SMOVE)			Interpol. axes (XMOVE)
	TSX CAY 21/41	TSX CAY 22/42/33	TSX CFY 11/21	TSX CAY 33
09 Move to the position and stop				
01 Move to the position without stopping				
10 Move until an event is detected and stop				
11 Move until an event is detected without stopping				
14 Homing				
04 Stop command				
05 Await an event				
07 Memorize the current position when an event occurs				
62 Forced homing				
30/32 Simple machining				
92 Initialization of memorized positions				
21 Move without stopping, with homing on the fly				
22 Flying shear on two axes		(1)		
90/98 Cutting mode (on position or on event)		(1)		

1.2

Possible instruction

These instruction codes can be represented as symbols by the user in G code (for example: 09 can be represented by G09).

The instruction codes are preceded by another code indicating the type of target position:

- 90 : if the target position is absolute.
- 91 : if the target position is relative to the current position.
- 98 : if the target position is relative to a memorized position (index).
- 60 : if the target position is absolute and movement direction is fixed (TSX CAY 22/42/33 only).
- 68 : if the target position is relative to a memorized position and movement direction is fixed (TSX CAY 22/42/33 only).

Programming a path

A complete path can be programmed by means of a series of SMOVE or XMOVE elementary motion control functions.

Grafcet language is ideal for this type of programming. An elementary movement is associated with each step.

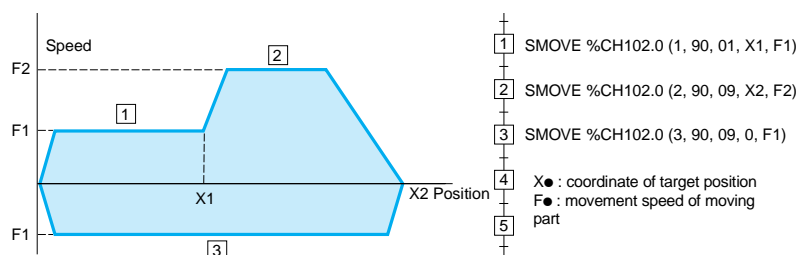

(10) Only with TSX CAY 22 module. Requires the version > 4.1 of PL7 Junior/Pro software TLX CD/RCD PL7/J/P P 41M. Not available with Unity Pro software.

TSX CAY/CFY module software setup (continued)

When setting up application-specific functions, screens specific to axis control and stepper control functions can be accessed via PL7 Junior/Pro software for configuration, adjustment, debugging and documentation of applications. These services are performed by editors which can be directly accessed from the basic screen using icons in the tool bars. Windows relating to the editors can be simultaneously displayed on one screen (example : it is possible to simultaneously program using the program editor and define the symbols in the variables editor).

Declaring the axis control modules and stepper control modules

Parameter entry screens for application-specific functions can be accessed via the configuration screen by clicking on the slot.

Example : modules TSX CAY 21 and TSX CFY 21 in which the module has been defined.



Configuring the modules

The configuration editor provides assistance with entering and modifying the values of the various axis configuration parameters. These parameters enable the operation of the axis control module (module TSX CAY 21 for example) to be adapted to the machine which is to be controlled.

Axis configuration parameters are :

- Units of measurement.
- Resolution.
- Type of encoder.
- Maximum and minimum limits.
- Maximum speed.
- ...

This data relates to the machine and cannot be modified by the program.



Adjusting the modules

These parameters are associated with operation of the axes. They generally require the operations on and movements of the moving part to be known. These parameters are adjusted in online mode (they are initialized during configuration, in offline mode).

They concern:

- Encoder offset.
- Resolution.
- Servo control parameters.
- ...



Debugging the modules

In online mode, the configuration editor also provides the user with a control panel screen, giving him a quick visual display which he can use to control and observe the behaviour of the axis.

The control panel provides different information and commands according to the selected operating mode :

- Automatic mode (Auto).
- Manual mode (Manu).
- Direct mode (Dir_Cde).
- Off mode (Off).



Architecture

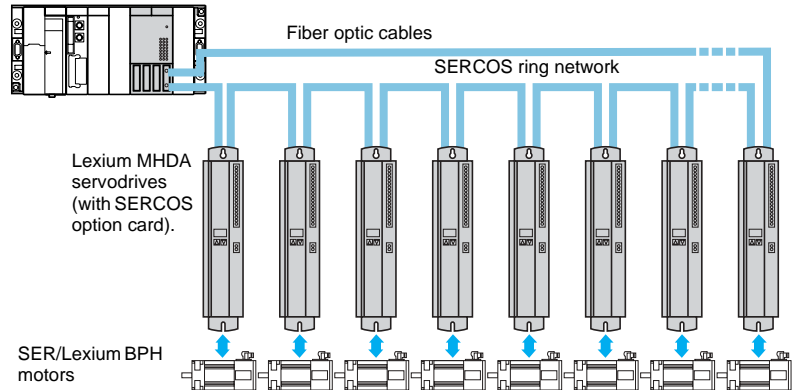

SERCOS (SERial Communication System) is a communication standard which defines the digital link (exchange protocol and medium) between a motion control module and intelligent servodrives. It is defined in European standard EN 61491. Using the SERCOS distributed architecture allows application I/O (position encoder, emergency stop, etc.) to be connected directly to the intelligent servodrives, reducing the cost of connection. The fiber optic digital link permits high speed exchanges (2 or 4 M bauds) while ensuring a high level of immunity in disturbed industrial environments.

The SERCOS range in the Premium control system platform comprises:

- Two TSX CSY 84/164 axis control modules which can each control up to 16 servodrives via a SERCOS ring. The module calculates the path and interpolation for several axes (position mode). Access to the other modes (speed and torque) is possible with the assistance of Schneider Electric application services.
- 1.5 A to 70 A Lexium MHDA servodrives with digital link (equipped with SERCOS option card). The servodrives manage the position loop, speed loop and torque loop, and ensure power conversion to control the motor. The encoder feedback information is sent to the servodrive (current position, current speed).
- SER/Lexium BPH brushless motors. These have permanent magnets delivering a high power-to-weight ratio, resulting in excellent dynamic speed response in a compact unit.

The Lexium range offers all the accessories required (filter choke, braking resistor, etc.) and a full set of connectors.

System overview

The system overview presents the various functions performed by the different parts of the multi-axis control system.

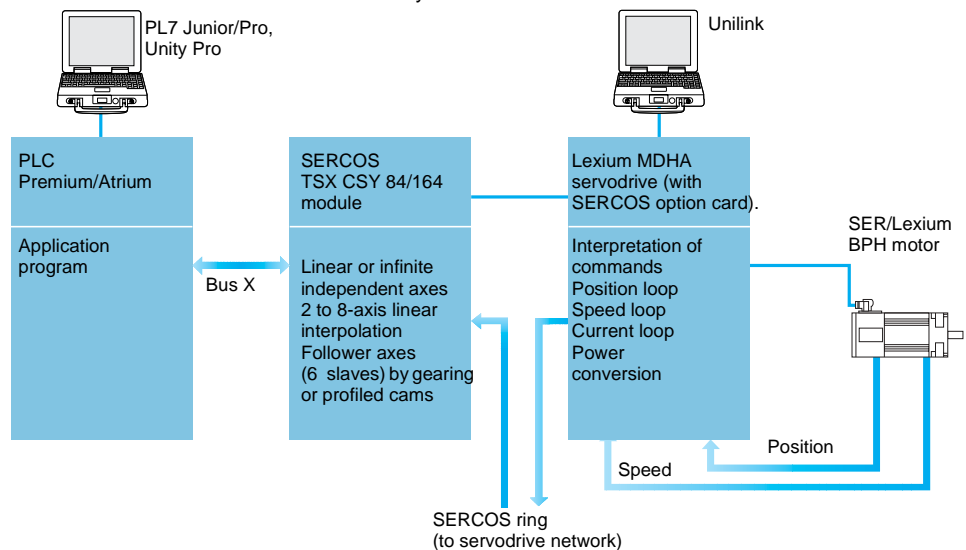

System overview (continued)

PL7 Junior/Pro or Unity software via the Premium platform terminal port can:

- Declare TSX CSY 84/164 SERCOS modules (1) in the PLC configuration.
- Configure the functions and define the parameters for the axes used.
- Program the movements in the PLC application.
- Adjust the parameters via the operating codes (parameters, TSX CSY module and Lexium MHDA servodrives) (2).
- Test and debug the application.

Unilink software, via the RS 232 terminal port for the Lexium MHDA servodrive (2) can:

- Define types of Lexium MHDA servodrives (2) and SER/Lexium BPH motors.
- Adjust the parameters for Lexium MHDA servodrives (2), back them up to EEprom memory in the drive and save them on a compatible PC.

Description



The TSX CSY 84/164 SERCOS axis control modules comprise:

- 1 A SMA-type connector, marked Tx, for connecting the servodrives using the SERCOS ring fiber optic transmission cable.
- 2 A SMA-type connector, marked Rx, for connecting the servodrives using the SERCOS ring fiber optic reception cable.
- 3 Rigid cases, double format, in order to:
 - Support electronic cards
 - Attach and lock the module in its slot.
- 4 Module diagnostic lamps:
 - RUN LED (green): LED ON indicates module operating correctly.
 - SER LED (yellow): flashing LED indicates data transmission and reception on the SERCOS network
 - ERR LED (red):
 - LED ON indicates internal module fault,
 - flashing LED on module start up indicates communication fault, incompatible configuration or application missing.
 - I/O LED (red): LED ON indicates external fault or application fault.
 - INI LED (yellow): flashing LED indicates module is reinitializing.
- 5 Channel diagnostic LEDs (green): LED ON indicates axis operating normally; OFF: configuration fault; flashing: serious error on axis:
 - 1 to 8: display of 8 real axes (3).
 - 9 to 12: display of 4 imaginary axes (3).
 - 13 to 16: display of 4 remote axes (3).
 - 17 to 20: display of 4 coordinated sets.
 - 21 to 24: display of 4 follower sets.
- 6 A pencil point button to initialize the module.
- 7 Two mini DIN type 8-way connectors for Schneider Electric use.

(1) TSX CSY 164 module can not be implemented with Unity Pro V1.0 software.

(2) Lexium MHDA servodrive equipped with AM0 SER 001V000 SERCOS option card.

(3) 1 to 16: display the 16 axes (real, imaginary or remote) with module TSX CSY 164.

Modicon Premium automation platform

SERCOS TSX CSY 84/164 motion control module

Characteristics				TSX CSY 84		TSX CSY 164				
Electrical characteristics				TSX CSY 84		TSX CSY 164				
SERCOS ring network	Type	Industrial medium complying with standard EN 61491								
	Topology	Ring								
	Medium	Fiber optic cable								
	Baud rate	M bauds	4 by default							
	Cycle time (1) (independent axes)	ms	2 axes 2	4 axes 2	8 axes 4	2 axes 2	4 axes 2	8 axes 2	12 axes 3	16 axes 4
	Maximum number of segments		9				17			
	Length of segment	m	38 max. with plastic fiber optic cable, 150 max. with glass fiber optic cable							
	Bus X	Distance	m	100 max. (2) between TSX CSY 84 axis control module and the Premium processor						
SERCOS certification (3)		TSX CSY 84/164 modules comply with SERCOS CEI/EN 61491 certification and with the tests determined by IGS (Interest Group SERCOS). Certification N° Z00030								
Power consumption for $\bar{\bar{\bar{}}}$ 5V voltage		mA	1800							
Power dissipated in the module		W	9 (typical)							
Operating characteristics				TSX CSY 84		TSX CSY 164				
Number of channels		32 configurable (0 to 31), channel 0 used for SERCOS ring configuration								
Type of axes	Real axes (connected to a servodrive)	8 (channels 1 to 8)				16 (channels 1 to 16) may be dynamically configured as real axes, imaginary axes or remote axis.				
	Imaginary axes	4 (channels 9 to 12)								
	Remote axes (4)	4 (channels 13 to 16)								
Set of axes	4 coordinated (channels 17 to 20). Each set allows linear interpolation of 2 to 8 axes									
	4 followers (channels 21 to 24). Each set can comprise a maximum of 7 axes: 1 master/6 slaves in gearing or camming									
Cam profile		7 (channels 25 to 31). Used to create the electronic cams with linear or cubic interpolation between profile points								

(1) 4 ms default value. Values may be programmed according to number of axes.

(2) Without the use of a TSX REY 200 bus X remote module.

(3) For further certification details, see pages 8/8 and 8/9.

(4) Determine external position using an encoder connected to the servodrive position input.

Characteristics (continued)

Main functions

Programming	Movements	<ul style="list-style-type: none"> ■ Homing, absolute, relative, or continuous ■ Immediate movement, or queued, to a given position ■ Speed override possible ■ Acceleration and deceleration parameters may be set for each axis motion control (1) ■ Synchronisation on start and desynchronisation on stop for a slave axis on a master axis, in a given position (1) ■ Rollover counter (1)
	Special functions	<ul style="list-style-type: none"> ■ Capture position and distance measurement between two edges on one or two discrete inputs on the drive. This can be applied to a real or remote axis (position measurement via external encoder) ■ Count probe: counts the edges on a discrete input on the drive over a period of time ■ Fast index: starts a movement on an event ■ Registration move: position capture on an edge of the discrete input on the drive ■ Rotary Knife: cuts using a rotary knife. Synchronizes a circular axis on a linear axis and controls a discrete output on the drive
	Other special functions	The development of all other special function is possible with the assistance of our application services. Please consult our Regional Sales Offices .
	Stop/start functions	<ul style="list-style-type: none"> ■ Fast stop, stop on configured deceleration profile ■ Temporary stop ■ Restart of stopped movement ■ Choice of stop method (1): <input type="checkbox"/> On faulty slave: master is not stopped. master stops normally according to pre-determined deceleration ramp or Servo-driven master emergency stop <input type="checkbox"/> On faulty master: slave stops normally according to pre-determined deceleration ramp or Servo-driven slave emergency stop ■ On Emergency Stop: calculation of slave axis deceleration ramp alignment with master axis so that obtains the synchronization stop of all set axes. (1) ■ Emergency Stop: axes may be allowed to "freewheel" or may be stopped according to pre-determined ramp (1)
Configuration /adjustment	SERCOS ring	Bus cycle time, traffic on the bus, optical power on the fiber, SERCOS loop diagnostics
	Acceleration/deceleration	Ramp values, ramp type (rectangular, triangular and trapezoid), choice of units, maximum acceleration adjustment
	Speed	Speed units, default speed, maximum speed, speed override
	Other settings	Target window, rollover, software limits
	Set of follower axes	Following of master axis by gearing or camming (cam profile), threshold position of master triggers the following, bias value when synchronizing an axis, monitoring of master/slave positions, master offset for follower axis
	Set of coordinated axes	Type of interpolation: linear
	Cam profile	Value of an existing point of a cam profile, number of points (5000 max.), type of interpolation, table addresses
	State of a movement or axis	Moving, accelerating, decelerating, homing, in position, faulty, etc.
	Diagnostics	<ul style="list-style-type: none"> ■ Drive fault, axis currently reading data, following error, overvoltage, undervoltage, overcurrent, power supply fault ■ Availability of master axis fault information for a given axis set (1) ■ Multiaxis motion path control according to common tolerance for all axes in the motion, with alarm feature. Access available only with TSX CSY 164 module

(1) Implementation of the TSX CSY 84, release ≥ 1.3 requires the use of the PL7 Junior/Pro software, version ≥ 4.4. Access available only with TSX CSY 164 module.

Software setup (1)

When setting up application-specific functions, screens specific to SERCOS axis control functions can be accessed via PL7 Junior/Pro or Unity software for configuration, adjustment, debugging and documentation of applications. These services are performed by editors which can be directly accessed from the basic screen using icons in the tool bars. Windows relating to the editors can be simultaneously displayed on one screen (example: it is possible to program using the program editor and simultaneously define the symbols in the variables editor).

Declaring the SERCOS motion control modules

Parameter entry screens for application-specific functions are accessed via the configuration screen by clicking on the slot.

Example: configuration in which a TSX CSY 84/164 module has been defined.



4

Configuring the module

The configuration editor provides assistance with entering and modifying the values of the various axis configuration parameters. These parameters enable the operation of the axis control module to be adapted to the machine which is to be controlled. Axis configuration parameters are:

- Units of measurement.
- Resolution.
- Maximum and minimum limit positions.
- Maximum speed.
- Accelerating/decelerating.

This data relates to the machine and cannot be modified by the program.

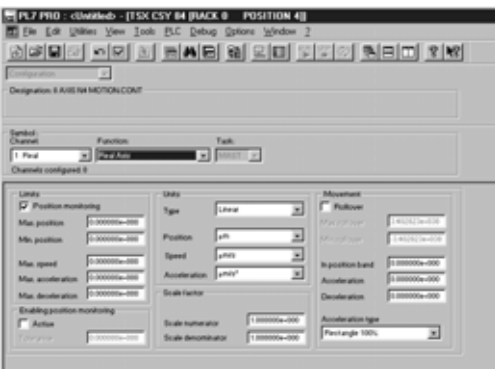

1.2

The following configuration screen can be used to declare the 16 axes as real, imaginary or remote measurement axes in module TSX CSY 164.

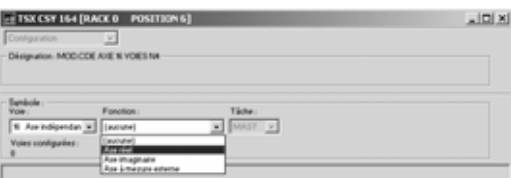

(1) The setting up screens require the version ≥ 4.1 of PL7 Junior/Pro software TLX CD/RCD PL7J/P P41M/42M/43M/44M or Unity Pro UNY SPU ●FU CD 10.

Software setup (continued)

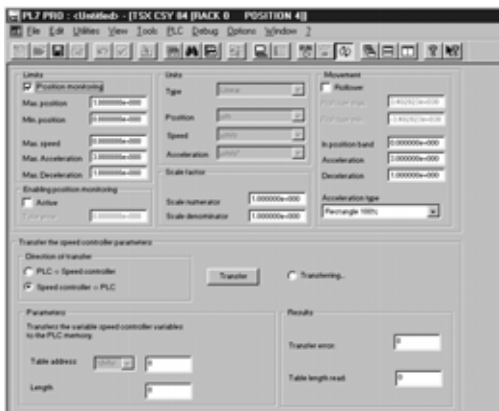

Adjusting the modules

These parameters are associated with operation of the axes. They generally require the operations on and movements of the moving part to be known. These parameters are adjusted in online mode (they are initialized during configuration, in offline mode).

They concern:

- Maximum speed.
- Resolution.
- Servocontrol parameters.
- Accelerating/decelerating.



Debugging the modules

In online mode, the configuration editor also provides the user with a control panel screen, giving a quick visual display which can be used to control and observe the behavior of the axis.

The TSX CSY 84/164 module associated with PL7 Junior/Pro software (1) provides manual mode for running continual (JOG) or incremental (INC) motion commands without prior programming.

(1) Mode not available with Unity Pro.

Modicon Premium automation platform

SERCOS TSX CSY 84/164 motion control module

References

The TSX CSY 84/164 multi-axis control module has 32 application-specific channels which are only counted when they are configured in the Premium application (using PL7 Junior/Pro or Unity Pro software). The maximum number of application-specific channels allowed depends on the type of processor:

Type of processors	TSX/57 1●	TSX/57 2● PCX 57-20 PCI 57-20	TSX/57 3● PCX 57-35	TSX/57 4● PCI 57-45	TSX/57 5●
Maximum number of application-specific channels	8	24	32	64	64



TSX CSY 84 164:

Description	Functions	Number of axes	Reference	Weight kg
Multi-axis control modules	SERCOS digital servodrives control	8 real axes 4 imaginary axes 4 remote axes	TSX CSY 84	0.520
		16 axes (real axes, imaginary axes or remote axes)	TSX CSY 164 (1)	—

Connection accessories

Description	Connection	Length	Reference	Weight kg
Plastic fiber optic cables fitted with SMA-type connectors (curvature radius: 25 mm min.)	Lexium MHDA servodrive 1●●●N00/A00 (with SERCOS option card)	0.3 m	990 MCO 000 01	0.050
		0.9 m	990 MCO 000 03	0.180
		1.5 m	990 MCO 000 05	0.260
		4.5 m	990 MCO 000 15	0.770
		16.5 m	990 MCO 000 55	2.830
		22.5 m	990 MCO 000 75	4.070
		37.5 m	990 MCO 001 25	5.940

Sets of plastic fiber optic connections

Description	Composition	Reference	Weight kg
Set of fiber optic cables and SMA-type connectors	12 SMA-type connectors 12 insulating sleeves Plastic fiber optic cable, length 30 m	990 MCO KIT 01	—
Fiber optic cable installation tool	Tools for making up cables to required length from a 990 MCO KIT 01 kit Includes stripping tool, crimping pliers, 25 W/110 V cutting tool, and instructions for use	990 MCO KIT 00	—

Separate item

Description	Use	Reference	Weight kg
PC to TSX CSY 84/164 connectors connection cable (length 2 m)	Used to download the servodrive operation configuration file for the servodrives present on the SERCOS ring (2) Used to download specific functions developed by our Industrial Applications Department.	TSX CCT 200	0.100

(1) The TSX CSY 164 module is compatible with version 4.3 of the PL7 Junior/Pro software application with the Motion software add-on update included on the TSX CSY 164 module CD-Rom. Version 4.4 of PL7 Junior/Pro includes this software add-on. The TSX CSY 164 module is not compatible with Unity Pro version 1.0 software.

(2) The add-on can be downloaded when the default configuration file is not adapted to the configuration required.

Modicon Premium automation platform

SERCOS TSX CSY 84/164 motion control module

Connections

SERCOS ring with 5 servodrives (example)

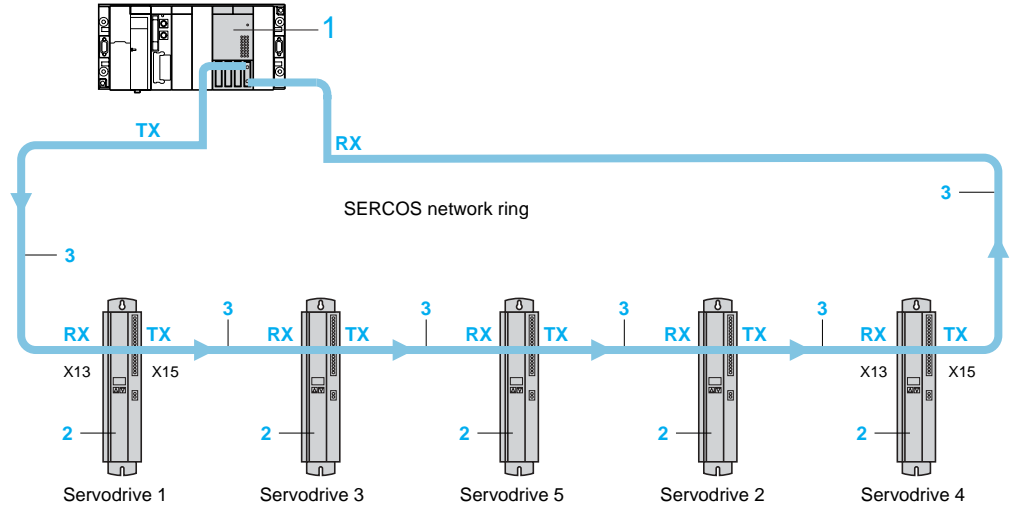

- 1 TSX CSY 84/164: multiaxis control module for Premium.
- 2 MHDA 1●●N00/A00 Lexium servodrives fitted with the SERCOS AM0 SER 001 V000 option card.
- 3 990 MCO 000 ●●: plastic fiber optic cables fitted with SMA type connectors.

TX Transmission.

RX Reception.

Modicon Premium automation platform

Presentation

Analog setpoint or digital link mode

Stand alone mode with integral position indexer

The axis control offer is intended for machines which simultaneously require high performance servo motion control, associated with PLC sequential control.

Position control system

Modicon Premium and Modicon Quantum automation platforms offer a range of interfaces including axis control modules providing a position control function. These modules are:

- Analog output modules:
 - TSX CAY, multi-axis control (2 to 4 axes) for Premium,
 - 140 MSB, single-axis control for Quantum
- Modules with SERCOS digital link:
 - TSX CSY, controls up to 16 servodrives for Premium,
 - 141 MMS, controls up to 22 servodrives for Quantum.

Lexium MHDA servodrive

Lexium servodrives provide solid state switching, current (or torque), speed and position control.

Three types of servodrive, each available in 7 current ratings (1.5, 3, 6, 10, 20, 40 and 70 A permanent rms), are available:

- ± 10 V analogue setpoint, controlled by position control module of PLC.
- Stand alone mode with integral position indexer, controlled by:
 - discrete inputs/outputs (1),
 - CANopen bus,
 - Modbus Plus network, Fipio bus or Profibus DP bus (1).
- SERCOS high speed digital link (1) allows Lexium servodrives to be controlled by PLC position control module.

Lexium brushless motors

Brushless motors are synchronous, 3-phase motors. They are equipped with a built-in sensor which can be a resolver or a SinCos Hiperface absolute encoder. They are provided with or without holding brake. Two ranges of motors are available:

SER motors

They are equipped with Neodymium Iron Borium (NdFeB) magnets and provide a high power density within a confined space, as well as large velocity dynamic that meet all machine requirements. They have:

- IP 41 or IP 56 protection.
- With or without gearbox. These gearboxes are offered with three speed reduction ratios 3:1, 5:1 and 8:1.
- Smooth shaft end (2) (for the model without gearbox) or with key (for the model with gearbox).

BPH motors

Their design, with samarium cobalt permanent magnets, ensures perfect rotation even at low speed. Depending on the model, they have:

- IP 65 or IP 67 protection (IP 54 for BPH 055 motor).
- Keyed or smooth shaft ends.

Configuration and installation

Motion control applications are designed and installed using:

- PL7 Junior/Pro (for Premium PLCs) software.
- Concept (for Quantum PLCs) software.
- Unity Pro (for Premium or Quantum PLCs) software.

Unilink user software, in association with Lexium servodrives, provides configuration and adjustment of the parameters for these servodrives.

(1) Requires use of an optional card (one slot available per MHDA servodrive).

(2) Shaft end with key for the model without a gearbox, please contact our Regional Sales Office.

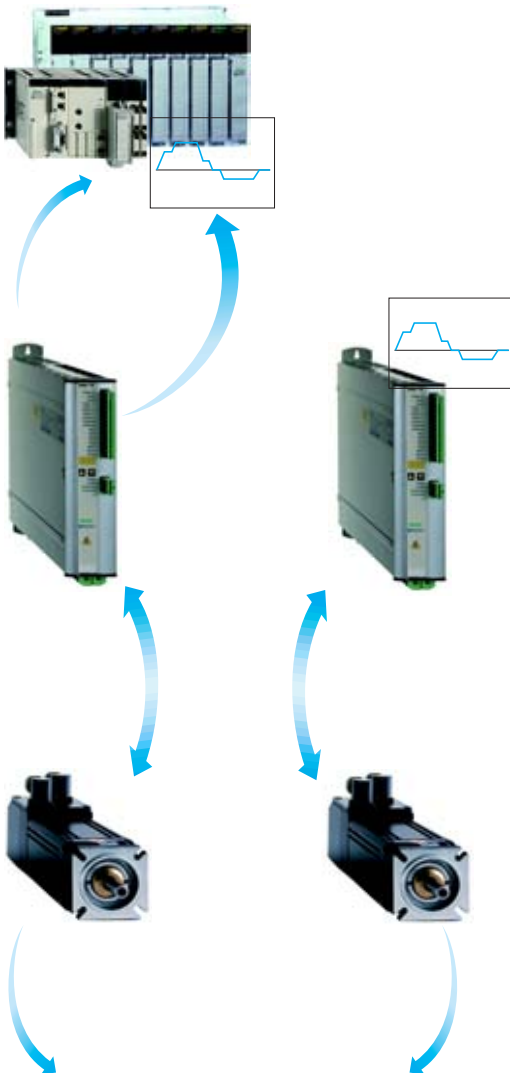

Modicon Premium automation platform

Association of brushless motors and Lexium servodrives

SER brushless motors (IP 41 or IP 56)		Digital Lexium MHDA servodrives						Lexium BPH brushless motors (IP 65 or IP 67)	
									
		MHDA 1004N	MHDA 1008N	MHDA 1017N	MHDA 1028N	MHDA 1056N	MHDA 1112N	MHDA 1198N	
		1.5 A rms	3 A rms	6 A rms	10 A rms	20 A rms	40 A rms	70 A rms	
									0.4/1.1 Nm
									8,000 rpm
									BPH 0552 S
									0.9/1.9 Nm
			1.3/3.4 Nm						6,000 rpm
									BPH 0751 N
SER 39A 4L7S	6,000 rpm	1.1/2.5 Nm	1.1/4 Nm						
SER 39B 4L3S	6,000 rpm		2.2/4.4 Nm	2.2/8.0 Nm					
			1.3/2.5 Nm	2.3/4.8 Nm					6,000 rpm
									BPH 0752 N
SER 39C 4L3S	6,000 rpm		2.9/4.7 Nm	2.9/9.4 Nm					
				3.7/7.2 Nm	4.3/13.4 Nm				6,000 rpm
									BPH 0952 N
SER 3BA 4L3S	6,000 rpm			4.6/9.2 Nm	4.6/15.3 Nm				
SER 3BA 4L5S	6,000 rpm		4.6/8.2 Nm	4.6/15 Nm					
				6.0/13.4 Nm	6.0/20.3 Nm				6,000 rpm
									BPH 0953 N
SER 3BB 4L3S	6,000 rpm			6.6/12 Nm	6.6/20 Nm				
SER 3BB 4L5S	6,000 rpm			6.6/15.8 Nm	6.6/25 Nm				
				7.4/13.6 Nm	7.4/19.3 Nm				6,000 rpm
									BPH 1152 N
				6.8/13.5 Nm	10.5/19 Nm				6,000 rpm
									BPH 1153 N
SER 3BC 4L5S	6,000 rpm			10/17 Nm	10/28 Nm				
SER 3BC 4L7S	3,000 rpm		10/16 Nm	10/32 Nm					
					11.4/18 Nm	12/30 Nm			4,000 rpm
									BPH 1422 N
SER 3BD 4L5D	6,000 rpm				13.4/29 Nm				
SER 3BD 4L7S	3,000 rpm			13.4/24 Nm	13.4/38 Nm				
					14.5/24 Nm	17/42 Nm			4,000 rpm
									BPH 1423 N
						25/37.5 Nm			4,000 rpm
									BPH 1902 N
						36/57 Nm			4,000 rpm
									BPH 1903 K
						46/76.2 Nm			4,000 rpm
									BPH 1904 K
						75/157 Nm			4,000 rpm
									BPH 1907 K
						90/163 Nm	100/230 Nm		4,000 rpm
									BPH 190A K

1.1/2.5 Nm For a SER motor, the 1st value corresponds to continuous stall torque max., the 2nd value corresponds to peak stall torque max.
1.3/3.4 Nm For a SER/Lexium BPH motor, the 1st value corresponds to continuous stall torque max., the 2nd value corresponds to peak stall torque max.
Example: The **SER 3BB 4L3S** motor associated with the **MHDA1017** servodrive meets the requirements of applications requiring a 6.6 Nm continuous stall torque max., 12 Nm peak stall torque max. and 6,000 rpm mechanical speed.

Modicon Premium automation platform

ISP Plus integrated weighing system

The ISP Plus weighing range, when used with the Premium PLC, enables the automation of machines combined with weighers or installations

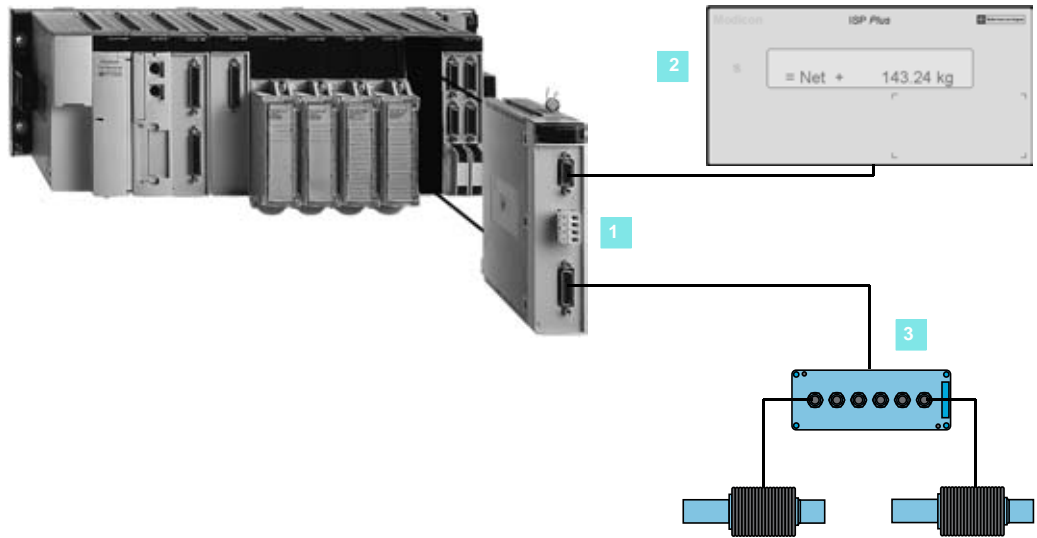

4

1 Weighing module

The TSX ISP Y100 standard format weighing module is the central part of the weighing system. It has:

- A measurement input which will take up to 8 sensors.
- A sealable link for the display unit.
- Two discrete reflex outputs for weigher doser applications.

The weighing module can be supplied factory calibrated.

2 Weight indicator

The TSX XBT H101 remote display unit displays the measured weight with no prior configuration. When the link to the weighing module is sealed, this display unit then becomes the main display unit for commercial transactions. The TSX ISP Y111 module/display unit assembly conforms to OIML recommendations and is C€ approved for class III weighers (6000 scale divisions) and for class IIII weighers (1000 scales divisions).

1.4

3 Load cells

Designed for harsh environmental conditions, strain gauge load cells are the third part of the weighing system. These load cells can be supplied pre-calibrated at the factory or by using a press. For load cells, accessories (enclosures, cables, simulators, etc.), and weighing platform.

Solutions for installing automatic weighing applications

Please consult our specialist catalogue AUTC000192212EN

Multiproduct batching

Batching 1 to 12 products from 32 stored in 16 silos : SP7 SA10



- 99 recipes.
- Batching at 2 flow rates.
- Assignment of silos/products.
- Tolerance checking.
- Automatic correction of in-flight error.
- Programmable order of product batching.
- Various weighing modes, batching in percentages.
- Management of totals by product and by recipe.

Weigher doser

Dosing set quantities into a container or an intermediate hopper: SP7 S●50

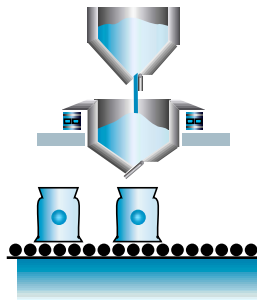

- 99 recipes.
- Automatic correction of the dose values.
- Alternating adjustment and production cycles.
- Automatic correction of in-flight error at end of adjustment cycle.
- Optimization of the production rate at each cycle.
- Adaptable reset frequency.
- Calculation of the average value and typical deviation, at the end of the adjustment cycle.
- Printing of results during adjustment cycles.

Weigher sorter

Checking and sorting objects by weight: SP7 S●60

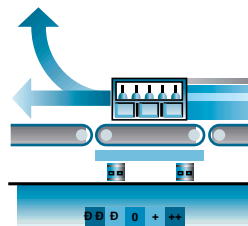

- 99 recipes.
- Sorting in relation to a setpoint and 2 tolerance values.
- Insertion of the sorting setpoint by scaling or on the basis of results.
- Calculation of the average value and typical deviation of a batch.
- Calculation of the number per category.
- Classification according to the weight deviation in relation to the setpoint.
- Continuous automatic tare except during sorting.
- Printing of results.

Discontinuous totalizer

Totalising successive weighing operations when receiving or dispatching materials in bulk: SP7 S●40

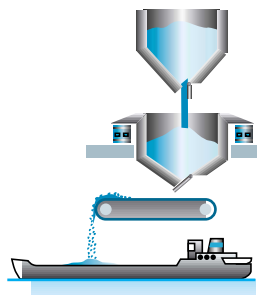

- 99 recipes.
- Receipt or dispatch operation.
- Filling at one or two flow rates.
- Ability to add further material.
- Automatic correction of in-flight error.
- Emptying of remainder.
- Selection of the reset frequency.
- Printing of results.

Control of flow rate on conveyor belt and continuous totalizer

Control of flow rate on conveyor belt by weight or speed: SP7 SA85

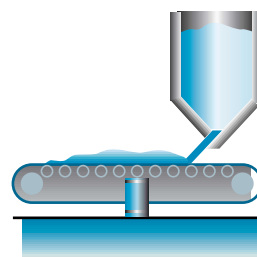

- Adjustable PID controller.
- Analog outputs for flow rate control and setpoint.
- Vibrator control output.
- Totalling of weight of product which has travelled along belt (one continuous totalizer and four partial totalizers).
- Output for mechanical totalizer.
- Semi-automatic tare.
- Digital calibration.
- Speed read by proximity sensor.
- Printing of results.

Modicon Premium automation platform

ISP Plus integrated weighing system

When a TSX ISP Y101 weighing module is plugged into a Premium programmable controller, it is possible to go beyond the scope of a simple weighing application. The PLC manages not only the entire weighing environment, but also the whole of the machine or industrial process associated with the weighing system.

In a Premium configuration, the number of TSX ISP Y101 weighing modules must be added to the other dedicated modules (TSX SCY 21601 communication, TSX CTY counting, TSX CAY/CSY axis control and TSX CFY movement control).

The maximum permissible is:

- 4 dedicated modules with TSX P57 103/153M processor.
- 12 dedicated modules with TSX P57 203/253M processor.
- 16 dedicated modules with TSX P57 303/353M processor.
- 32 dedicated modules with TSX P57 453M processor.

Description

Weighing module

The TSX ISP Y101 weighing module has the following on the front face:

- 1 A SUB-D 9-way female connector for the dedicated RS 485 serial link to the weight indicator.
- 2 A screw terminal block for connecting the 2 discrete reflex outputs (outputs used with threshold detection).
- 3 A SUB-D 15-way female connector for the indicator input channel (50 samples per second, from 1 to 8 load cells).
- 4 Module sealing device, if required.

Module TSX ISP Y101 and its load cells SF2/SF3/SM1/SM2 can be supplied calibrated (at the factory or using a press).

Weighing indicator

Weight values are displayed on a TSX XBT H100 weight indicator (supplied with the TSX ISP Y111 unit). The weight indicator is pre-configured.

It has the following on the front face:

- 1 An LCD, back-lit display screen with 1 line of 20 characters (height 9 mm).
- 2 An area for affixing the instrument rating plate.

The back is equipped with:

- A plug-in screw terminal block for $\overline{\text{---}}$ 24 V supply.
- A SUB-D 25-way female connector for connection to the TSX ISP Y101 weighing module (30 metres maximum).

Application solutions

See pages 4/60 and 4/61.

4

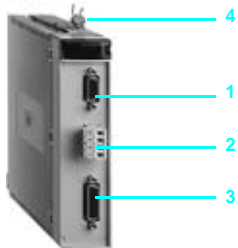

1.4

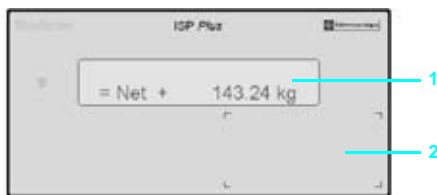

Functions

The weighing module with its associated display unit constitutes a weighing indicator. The module incorporates numerous functions specific to weighing:

- Continuous weighing (in g, kg, t, lb, oz...) and flow calculation (weight variation).
- Filtering of measurements by several methods (19 filtering options).
- Tare (automatic/manual) and preset tare.
- Automatic reset.
- Weighing stability control.
- Threshold detection with extrapolation of the cut-off point: positioning of local "discrete" outputs to the nearest millisecond.
- Assisted calibration: the module calculates the zero point and the gradient.
- Calibration parameters saved in the module (EEPROM) and in the Premium processor.
- Forced calibration: fast replacement of a failed module and restarting using the previous calibration parameters.
- Locking of the configuration, sealing of the module and its connections to the load cells and weight indicator.
- Continuous formatting and transmission of measurements to the PLC.
- Transmission of measurement validity data (validity, stability, nett/gross...).
- Transmission of diagnostic data from the module and its connections.
- Configuration, calibration and debugging via PL7 screens.
- Most of the operating parameters can be modified and most of the functions can be run by PLC program.

Setting up the weighing module

PL7 Junior/Pro software allows complete setting up of the weighing system (configuration, calibration and debugging).

Configuration

This covers:

- The measuring data of the weigher.
- Filtering of measurements.
- The flow calculation method.
- The tare.
- Data format.
- Stability criteria and zero point management method.
- Threshold monitoring for positioning of discrete outputs.

Weigher calibration

The module itself calculates the gain and the offset to be applied to the electronic weighing system.

Calibration is carried out in two phases:

- Measurement of the dead load.
- Measurement of a standard weight.

Forced calibration allows immediate restarting of the system in the event of a module failure; the new module is configured automatically.

Debugging

The dedicated weighing screen provides the following dynamic display:

- The measurement in progress.
- The operating state of the module.

It also allows fast modification of setting parameters (filtering, flow, threshold values...).

Instructions and parameters that can be modified by the program in real time with the module.

These parameters and instructions can be monitored from an operator dialogue type device and/or a supervisory device connected to the Premium.



Configuration



Weigher calibration

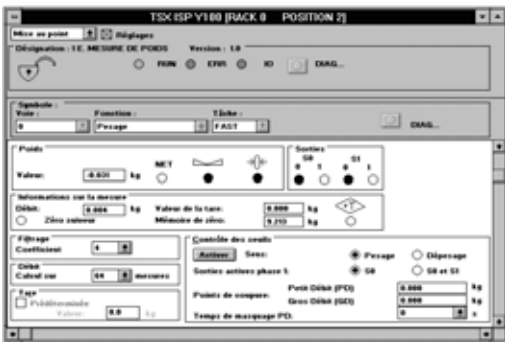

Debugging



Electrical characteristics of weighing module TSX ISP Y101

Measurement input	1 weigher per module		1 measurement input
	Resolution		1 048 576 points (20 bits)
	Measuring rate		50 measurements per second
	Input impedance	MΩ	> 1
Input load cells	Number that may be connected		Maximum of 8 x 350 Ω load cells, connected in parallel
	Supply voltage	V	--- 10
	Supply type		d.c.
	Cabling distance	m	300 (without loss of accuracy with 4 load cells)
Discrete reflex outputs	Number		2 positive logic transistor outputs, for sack weighing, filling and sort/check weighing.
	Nominal voltage	V	--- 24
	Nominal current	mA	500
	Response time		1 ms discrimination. The point at which the thresholds are crossed between 2 measurements is calculated by polling to the nearest millisecond.
Weight indicator output	Physical interface		RS 485 non isolated
	Binary flow	K bit/s	9.6
	Remote connection distance	m	30 (maximum)
Consumption		mA	See pages 8/4 and 8/5
Environment	Weights and measures		See page 1/16 The weighing module associated with its weight indicator conforms to OIML recommendations. It is C€ approved for class III (up to 6000 divisions) and class IIII (up to 1000 divisions) weighers in accordance with European circular 90 384 of 20th June 1990.
	Minimum voltage division	μV	1
	C€ certification		SDM n° 97.06 - Revision of 15 June 1999

Characteristics of weight indicator TSX XBT H100

Display	Type of screen		LCD back-lit
	Number of lines		1 line used for weighing applications
	Number of characters		20 per line
	Character size (height)	mm	9
Alimentation	Nominal voltage	V	--- 24 non isolated
	Limit voltages	V	--- 18...30
	Consumption	W	10
Environment	Conforming to standards		IEC 1131 2, EN 61131 2, UL 508, CSA C22 2 n° 14
	Temperatures		Operation: 0...50 °C. Storage: - 20...+ 60 °C
	Degree of protection		Front face : IP 65. Back: IP 20, conforming to IEC 529 and NF C 20 010
Function	Signalling		1 signal lamp



TSX ISP Y101



TSX ISP Y111



SM1 PS371



TSX XBT H100

Modules de pesage ISP Plus

Description	Composition	Calibration	Reference (1)	Weight kg
ISP Plus weighing modules (1 weigher per module)	Standard format module (sealable) - Load cell input 50 meas./s (for 1 to 8 load cells), - 2 reflex discrete outputs (for threshold detection), - RS 485 output (for display)	Module supplied not calibrated	TSX ISP Y101	0.420
		Module supplied calibrated (2)	TSX ISP Y101C1	0.420
	- Module TSX ISP Y101.	Module supplied not calibrated	TSX ISP Y111	1.020
	- Indicator XBT H100 (LCD back-lit, preconfigured display). - Module/weight indicator connecting cable (length 3 m)	Module supplied calibrated (2)	TSX ISP Y111C1	1.020

Documentation

Description	Manual format	Language	Reference	Weight kg
Setting-up manual for hardware and dedicated weighing software	A5 bound	French	TSX DM ISP Y100F	1.120
		English	TSX DM ISP Y100E	1.120
		German	TSX DM ISP Y100G	1.120
		Spanish	TSX DM ISP Y100S	1.120

Accessories for maintenance test (supplied with a 4 m cable)

Function	For use with	Mounting	Reference	Weight kg
Load cell simulation	ISP Plus all models	Separated	SM1 PS371	0.520
Test circuit (voltage)	ISP Plus and ISP7 A	Separated	SM1 PS381	0.100

Remote weight indicator

Description	Reference (1)	Weight kg	
Weight indicator for connection to the weighing module	TSX XBT H100		
Description	Length m	Reference	Weight kg
Module/weight indicator connecting cable	5	SF3 CPY005	0.500
	10	SF3 CPY010	1.100
	15	SF3 CPY015	1.700
	20	SF3 CPY020	2.200
	25	SF3 CPY025	2.800
	30	SF3 CPY030	3.400

Associated services

Calibration of Telemecanique load cells at the factory or using a press Consult our Sales Regional Office

(1) Supplied with multilingual Installation manual as standard: French and English.

(2) Calibration for load cells SM1 PW●● must be ordered separately, but at the same time as module TSX ISP Y1●1C1 and the load cells.

Dimensions

Weight indicator TSX XBT H100

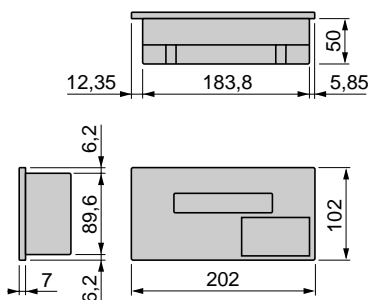

Flush mounting

Fixing by 4 or 6 press-in fasteners (supplied) (on 1 to 6 mm thick panel)

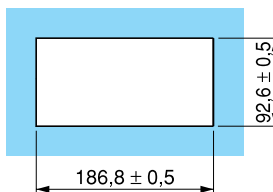

Modicon Premium automation platform

Premium Warm Standby redundancy

Presentation

The Premium Warm Standby redundancy offer ensures continuity of operation for a control system based on a Premium platform in the event of failure of:

- Central processing and communication functions.
- All or part of the I/O system.

It is based on the "Normal/Backup" redundancy principle with complete redundancy of the main processing and communication functions, the use of simple I/O shared on a Fipio bus and/or redundancy of in-rack I/O.

It covers all availability requirements when the purpose of the PLC is to monitor an installation in continuous operation, signal incidents to a control station, and transmit command instructions from the supervision manager to various locations on an extensive site. It is aimed at processes which can tolerate a lack of control on the part of the PLC lasting 1 to 2 s (average time for changeover from the "Normal" to the "Backup" unit).

Areas of application:

- In the commercial sector:
 - centralised technical management of a public facility (tunnel, airport, etc),
 - control/monitoring of a water treatment or distribution station,
 - electrical technical management.
- In the industrial sector:
 - food and beverage processing,
 - slow chemical processes,
 - level/temperature monitoring, etc.

Operational safety and availability

The Warm Standby architecture ensures that the control system functions are available, irrespective of the failure of any system component.

Operational safety in control systems:

Capacity to provide a specific service during the cycle

→ **Safety:** capacity of an entity to present no danger to people, goods and the environment

→ **Availability:** capacity of an entity to be operational, at any given moment or for a given period of time

→ **Reliability:** capacity of an entity to perform a service within a given time

→ **Ease of maintenance:** capacity of an entity to be maintained or returned to operational state within a given time

→ **Maintenance logistics :** capacity of an organisation to provide the necessary maintenance resources



4

1.4

Modicon Premium automation platform

Premium Warm Standby redundancy

Principle

The Premium Warm Standby architecture combines physical redundancy of the PLC with "Normal/Backup" type operation.

Only the "Normal" PLC processes the application and generates the outputs. The "Backup" PLC applies the outputs generated by the "Normal" PLC, performs self-diagnostics and permanently diagnoses the "Normal" PLC.

In event of a malfunction on the "Normal" PLC, the "Backup" PLC takes control and then becomes the "Normal" PLC (the faulty PLC, previously "Normal", becomes the "Backup").

Optimum availability of the application is ensured by:

- Automatic or manual "Normal/Backup" changeover.
- Smooth changeover on the actuators.
- Updating of the "Backup" PLC on each cycle.
- Signalling of the faulty component.
- Online repair.
- Transparent supervision (SCADA).

- Essential elements for redundancy
 - 1 TSX PSY power supply
 - 2 TSX P57 353M/453M processor
 - 3 TSX ETY 110 Ethernet TCP/IP communication module
- Optional elements for redundancy
 - 4 TSX ETY 210 Ethernet TCP/IP communication module
 - 5 TSX SCY 21601 communication module with TSX SCP 114 Modbus protocol PCMCIA card
 - 6 TSX PSY power supply
 - 7 TSX D●Y discrete I/O modules
- Shared elements on the Fipio bus

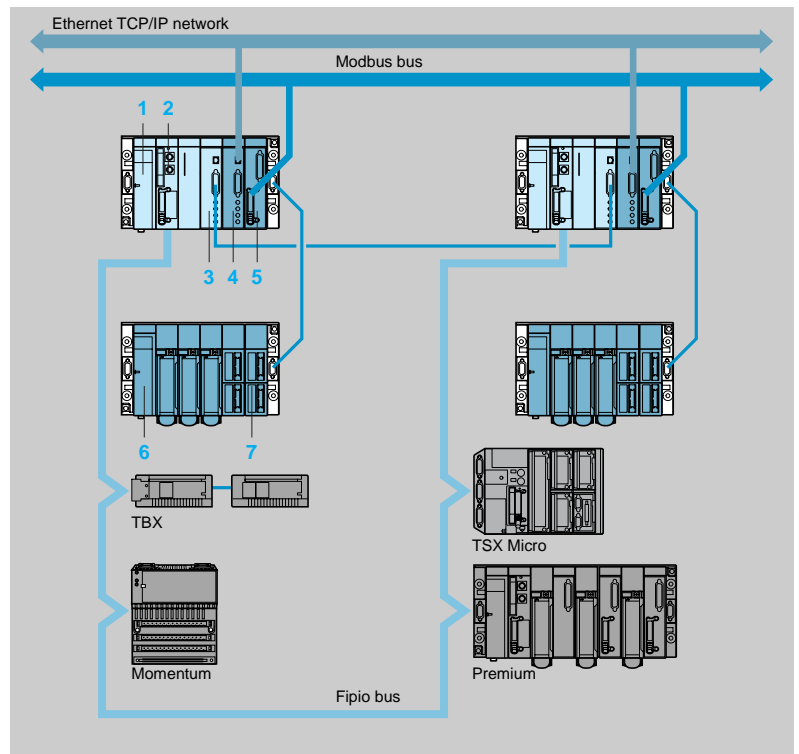

Elements which can be redundant are:

- The main rack.
- The main rack power supply.
- The processor.

Possibly accompanied by:

- Discrete input modules.
- Discrete output modules.
- One or more extendable racks with their power supply.
- One or more Ethernet TCP/IP network or Modbus bus communication modules.

Elements of the Fipio bus shared between the "Normal" and "Backup" PLCs are:

- Discrete or analog input modules (Momentum or TBX).
- Discrete or analog output modules (Momentum or TBX).
- One or more TSX Micro/Premium agent PLCs (these can support the entire range of I/O: discrete, analog or application-specific).

Functions

“Normal” and “Backup” PLC functions

The “Normal” and “Backup” PLCs are physically and functionally identical, but their role is differentiated according to their status: “Normal” or “Backup”.

The “Normal” Premium PLC:

- Executes the application.
- Updates the outputs and inputs (in-rack and on the Fipio bus).
- Provides communication functions with peripheral devices.
- Sends its database to the “Backup” PLC.
- Recovers diagnostic information from the “Backup” PLC.
- Generates its own diagnostic information as well as that of the Premium Warm Standby architecture.

The “Backup” Premium PLC:

- Executes part of the application.
- Reads the state of the in-rack inputs.
- Updates its in-rack and Fipio outputs according to the state of those of the “Normal” PLC.
- Provides communication functions with peripheral devices.
- Recovers diagnostic information from the “Normal” PLC.
- Generates its own diagnostic information as well as that of the Premium Warm Standby architecture.

Management of shared I/O on Fipio bus

The Fipio bus manages I/O exchanges on Fipio devices. The “Normal” PLC is an arbitrator for the active Fipio bus while the “Backup” PLC is an arbitrator for the passive Fipio network.

Due to the characteristics of the Fipio bus, only the “Normal” PLC reads the physical inputs on the Fipio bus and controls the physical outputs on the Fipio bus. The “Backup” PLC does not access the Fipio bus.

During each cycle, the “Backup” PLC receives the values of the I/O on the Fipio bus from the “Normal” PLC via the inter-PLC Ethway link (TSX ETY 110 module) and applies them to its own outputs. **This updating of the memory enables smooth “Normal/Backup” changeover** by maintaining the state of the I/O during changeover.

Management of “Normal/Backup” states

Malfunction of one of the following elements automatically causes a “Normal/Backup” changeover:

- Main rack power supply.
- PLC processor.
- TSX ETY 210 communication module.
- Fipio bus connected to the integrated processor port.

For all other elements, “Normal/Backup” changeover can be customised (manual changeover).

Management of optional redundant I/O

For redundant inputs, the sensor information is transmitted simultaneously to the “Normal” and “Backup” PLCs via the 2 input modules placed in each PLC. Two Telefast 2 16-channel sub-bases, ABE 7ACC10 with redundant inputs and ABE-7ACC11 with redundant outputs, can be used to perform this double wiring easily using preformed HE 10 connector connection cables, (see page 4/71, refs. 14, 15, 20 and 21).

The output values are only generated by the application processing of the “Normal” PLC. This sends its commands to the corresponding output modules.

During each cycle, the “Backup” PLC receives the “Normal” PLC output values via the inter-PLC Ethway link (TSX ETY 110 module) and applies them to its own outputs. **This updating enables smooth “Normal/Backup” changeover** by maintaining the state of the outputs during changeover.

Management of supervision transparency (SCADA)

Transparent communication with level 2 (supervisor, third-party device, etc) during changeover of the PLC in “Normal” mode to the PLC in “Backup” mode is provided by the TSX ETY 210 Ethernet TCP/IP modules, using a unique IP address.

Communication with a redundant architecture is therefore similar to that for a simple architecture.

This transparency is identical in Modbus with the use of the TSX SCP 114 PCMCIA card (Modbus protocol in RS 485) installed in the TSX SCY 21601 communication module.

Functions

Ring topology for shared equipment on the Fipio bus

To improve the availability of shared equipment on the Fipio bus, it is possible to create a Fipio redundant ring using fibre optics. The fibre optic ring can then be used to:

- Maintain normal operation in the event of a break at some point on the fibre optic medium.
- Increase the immunity of the Fipio bus in environments with high levels of electromagnetic interference.

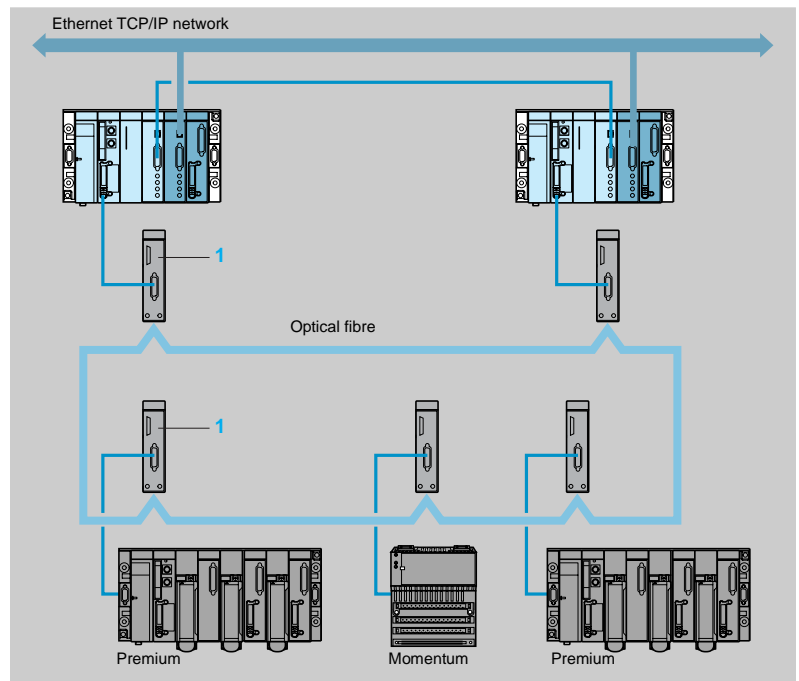

1 OZD FIP G3 fibre optic transmitter (see page 5/99).

Software setup

A Premium Warm Standby redundant architecture is set up using PL7 Junior/Pro software, in exactly the same way as a standard non-redundant process is set up. It is, however, necessary to apply the rule that the application program of both the "Normal" and "Backup" PLCs must be completely identical.

Redundancy entails certain special features which, if taken into account at the start of the development task, are very simple to set up using the additional Premium Warm Standby application design software TLX CD/CD3 WSBY P40E.

This software can be perform the following functions:

- Taking account of Normal/Backup states during program execution.
- Sharing the database between the 2 PLCs via DFB user function blocks and EF elementary function blocks.
- Management of redundant in-rack I/O.
- Management of shared I/O on the Fipio bus.

Modicon Premium automation platform

Premium Warm Standby redundancy

References

Description	Type	Reference (1)	Weight kg
Software packages for setting up a Warm Standby redundant architecture on Premium	Equipment with 1 station	TLX CD WSBY P40E	–
	Equipment with 3 stations	TLX CD3 WSBY P40E	–
Designation	Type	Reference	Weight kg
Ethernet TCP/IP communication module for Premium Warm Standby architecture	Identical to those of the TSX ETY 110 module (see page 5/38). For the Warm Standby architecture, this module also provides: - transparent addressing during changeover - diagnostics of the architecture (self-tests, state of the Ethernet link and of the TSX ETY 210 dual module), - la maintenance with access to the "backup" PLC	TSX ETY 210	0.270

Additional compatible elements

The Warm Standby architecture presented on page 4/67 shows, among other things, the essential elements for redundancy. Compatible standard modules can be added to this minimum configuration according to the requirements of the process being automated.

Elements for redundancy (sold in lots of 2) (2)

- Bus X remote system:
 - TSX REY 200 Bus X remote module, for increasing the length of Bus X to 2 x 350 m.
- Communication:
 - TSX ETY 210 Ethernet TCP/IP communication module, for communication with level 3,
 - TSX SCP 114 Modbus communication PCMCIA card, for Modbus Slave communication with transparent addressing for third-party devices. This card should be inserted in the slot in the TSX SCY 21601 communication module.
- Discrete and analog I/O:
 - TSX DEY ●●K discrete input modules with HE 10 connectors with ABE 7ACC11 Telefast 2 redundant sub-bases,
 - TSX DSY ●●K discrete output modules with HE 10 connectors with ABE 7ACC10 Telefast 2 redundant sub-bases,
 - TSX DMY ●●K discrete mixed I/O modules with HE 10 connectors with ABE 7ACC11/10 Telefast 2 redundant sub-bases,
 - TSX AEY/ASY analog, TSX CTY/CCY counter, TSX CAY/CSY/CFY axis control and TSX ISP weighing modules. These modules cannot be used as elements for redundancy, but can be used as elements shared via the Fipio agent Premium PLCs.

Shared elements on the Fipio bus

- TBX distributed I/O modules:
 - TBX LEP 030 Fipio communication module for base units,
 - TBX DES/DSS/DMS discrete I/O base units,
 - TBX AES/ASS/AMS analog I/O base units,
 - TSX EEF/ESF/EMF dust and damp proof discrete I/O base units.
- Momentum I/O modules:
 - 170 FTN 110 01 Fipio communication module,
 - 170 ADI/ADO/ADM discrete I/O base units,
 - 170 AAI/AAO/AMM analog I/O base units.
- Fipio agent PLCs:
 - Premium PLC, can take all I/O and application-specific modules,
 - TSX Micro PLC, can take all I/O and application-specific modules .
- Other shared elements:
 - OZF FIP G3 fibre optic transmitter, can be used to create a Fipio bus fibre optic ring,
 - TSX FP ACC 6 Fipio electrical repeater, increases the length of the bus by the creation of segments, each 1000 m maximum.

(1) Product supplied with setup manual in English.

(2) The TSX AEY/ASY I/O analog modules, the TSX CTY/CCY/CAY/CSY/CFY/ISPY application-specific modules are no redundancy elements. They can be used as shared elements with Fipio agent Premium PLCs.

Example of architecture with redundant I/O and shared I/O on Fipio bus

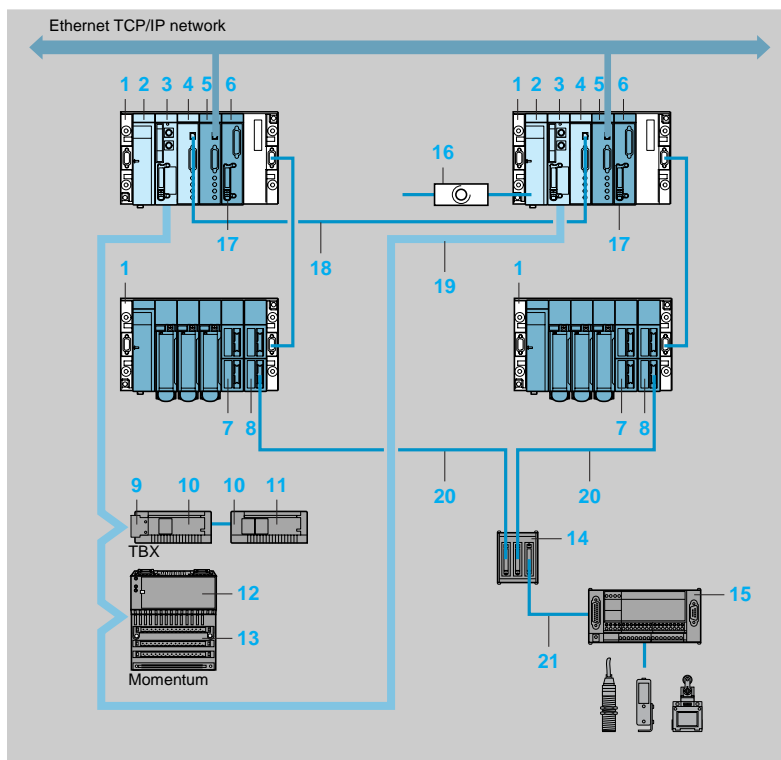

- 1 TSX RKY ●EX: Premium extendable rack.
- 2 TSX PSY●●●●M: power supply module.
- 3 TSX P57 353M/453M: Premium processor with integrated Fipio link.
- 4 TSX ETY 110: Ethernet TCP/IP network module.
- 5 TSX ETY 210: Ethway/Ethernet TCP/IP network module.
- 6 TSX SCY 21601: communication module for type III PCMCIA card.
- 7 TSX DSY●●K: discrete output modules, for redundancy.
- 8 TSX DEY●●K: discrete input modules, for redundancy.
- 9 TSX LEP 030: Fipio communication module for TBX base units with TSX BLP 01 connector.
- 10 TBX DES 16●●: distributed discrete output TBX base units, shared.
- 11 TBX DSS 16●●: distributed discrete output TBX base units, shared with TBX CBS 010 cache/cable.
- 12 170 FNT 110 00: Fipio communication module for Momentum base unit with TSX FPP ACC2 connector.
- 13 170 ADI/AAI/ADM●●●: discrete or analog I/O Momentum base unit.
- 14 ABE 7ACC11/10: Telefast 2 sub-bases for redundant I/O.
- 15 ABE 7●16●●●: Telefast 2 connection sub-bases.
- 16 LA4 DT2U: time-delay relay designed to desynchronise starting of the “Normal” PLC and the “Backup” PLC during simultaneous power-up.
- 17 TSX SCP 114: type III PCMCIA card for Modbus Slave communication.
- 18 490 NTW 000●●: preformed connection cable with RJ 45 connector, for interconnecting TSX ETY 110 modules (shielded twisted pair).
- 19 TSX FP CA●00: Fipio bus trunk cable, shielded twisted pair.
- 20 TSX CDP●53: preformed connection cable with HE 10 connector (length = 0.5, 1, 2, 3, or 5 m).
- 21 ABF H20H008: preformed connection cable with HE 10 connector (length = 0.08 m).