

Applications	These timing relays enable simple automation cycles to be set up using wired logic. They can also be used to complement the functions of PLCs.	
Output	Solid state Timing relays with solid state output reduce the amount of wiring required (wired in series). The durability of these timing relays is independent of the number of operating cycles.	Relay Relay outputs provide complete isolation between the supply and outut circuits. It is possible to have several output circuits.



Type	Modular	Industrial	Modular	Industrial
Timing ranges	7 ranges : 1 s, 10 s, 1 min, 10 min, 1 h, 10 h, 100 h	1 or 2 ranges, depending on model : 10 s, 30 s, 300 s, 60 min	7 ranges : 1 s, 10 s, 1 min, 10 min, 1 h, 10 h, 100 h	Depending on model : 4 ranges : 0.6 s, 2.5 s, 20 s, 160 s 7 ranges : 1 s, 10 s, 1 min, 10 min, 1 h, 10 h, 100 h 7 ranges : 1 s, 3 s, 10 s, 30 s, 100 s, 300 s, 10 min 10 ranges : 1 s, 3 s, 10 s, 30 s, 100 s, 300 s, 30 min, 300 min, 30 h, 300 h
Relay type	RE 88 826 0●●	RE9	RE 88 826 1●● RE 88 826 503	RE 88 865 ●●● RE7
Pages	28501/4 and 28501/5	28503/2	28502/4 and 28502/5	28509/4 to 28510/5 and 28504/2 to 28505/ 3

These timing relays enable simple automation cycles to be set up using wired logic. They can also be used to complement the functions of PLCs.

Relay
Relay outputs provide complete isolation between the supply and output circuits. It is possible to have several output circuits.



Optimum	Plug-in		Panel-mounted		
	Universal	Miniature	Analogue	Digital	Electromechanical
1 range, depending on model : 0.5 s, 3 s, 10 s, 30 s, 300 s, 30 min	7 ranges : 1 s, 10 s, 1 min, 10 min, 1 h, 10 h, 100 h	7 ranges : 1 s, 10 s, 1 min, 10 min, 1 h, 10 h, 100 h	Depending on model : 6 ranges : 1 s, 10 s, 1 min, 10 min, 1 h, 10 h 8 ranges : 1 s, 10 s, 1 min, 4 min, 10 min, 1 h, 10 h, 60 h	Depending on model : 7 ranges : 99.99 s, 999.99 s, 99 min 59 s, 99.99 min, 999.9 min, 99 h 59 min, 999.9 h 11 ranges : 99.99 s, 999.99 s, 9999 s, 99 min 59 s, 99.99 min, 999.9 min, 9999 min, 99 h 59 min, 99.99 h, 999.9 h, 9999 h	Depending on model : 3 ranges : 6 s, 60 s, 12 min 3 ranges : 6 min, 60 min, 12 h
RE8	RE 88 867 ●●●	RE 88 896 20●	RE 88 875 ●●● RE 88 896 ●●●	RE 88 857 ●●●	RE 88 226 ●●●
28507/2 to 28508/3	28511/4 to 28512/5	28513/3	28516/3, 28515/3	28517/5, 28518/5 and 28519/3	28520/3

Timing characteristics

Repeat accuracy (with constant parameters)	Conforming to IEC 1812-1		± 0.5 %
Drift	Temperature		± 0.05 % / °C
	Voltage		± 0.2 % / V
Setting accuracy at full scale	Conforming to IEC 1812-1		± 10 % at 25 °C
Minimum duration of control impulse	Typical	ms	50
Maximum reset time by de-energisation	Typical	ms	350
Immunity time to microbreaks	Typical	ms	> 10



Supply characteristics

Multivoltage supply			Depending on version, see pages 24501/4 and 24501/5
Frequency		Hz	50/60
Operating range			85...110 % Un
On-load factor			100 %
Maximum power consumption	Depending on model	\equiv 24 V	W 0.6
		\equiv 240 V	W 1.5
		\sim 240 V	VA 32

Output characteristics

Output type			Solid state
Breaking capacity		A	\sim/\equiv 0.7 at 20° C (0.5 A UL)
Derating		mA	5 / °C
Maximum permissible current		A	20 ≤ 10 ms
Minimum breaking current		mA	10
Leakage current		mA	< 5
Maximum switching voltage		V	\sim/\equiv 250
Typical voltage drop at terminals			3-wire 4V - 2-wire 8V
Electrical life			10 ⁸ operations
Mechanical life			10 ⁸ operations
Dielectric strength conforming to IEC 664, IEC 255-5		kV	2.5 at 1 mA / 1 min

Display characteristics

State indication by 1 LED	Green		Operating status indication:  Pulsing : relay energised, no timing in progress (except Di-D and Li-L)  Flashing : timing in progress  On steady : relay energised, no timing in progress
----------------------------------	-------	--	--

Input characteristics

Input type		V	Volt-free contact (no potential) Control possible by 3-wire sensor with PNP output, maximum residual voltage : 0.4 V whatever the supply voltage of the timer
-------------------	--	----------	--

Zelio Time - timing relays

Modular relays, solid state output
width 17.5 mm

General characteristics				
Conforming to standards			IEC 1812-1, EN 50081-1/2, EN 50082-1/2, LV directives (73/23/EEC + 93/68/EEC (CE marking) + EMC (89/336/EEC + IEC 669-2-3)	
Approvals			c UL us, CSA	
Temperature limits	Operation	°C	- 20...+ 60	
	Storage	°C	- 30...+ 60	
Creepage distance and clearance	Conforming to IEC 60664-1	kV	4 kV/3	
Degree of protection conforming to IEC 529	Terminal block		IP 20	
	Enclosure		IP 40	
	Panel-mounted		IP 50	
Vibration resistance	Conforming to IEC 68-2-6		f = 10...55 Hz A = 0.35 mm	
Relative humidity without condensation	Conforming to IEC 68-2-3		93 %	
Electromagnetic compatibility	Immunity to electrostatic discharge, conforming to IEC 1000-4-2		Level III (Air 8 kV/Contact 6 kV)	
	Immunity to electromagnetic fields, conforming to ENV 50140/204 (IEC 1000-4-3)		Level III 10 V/m : (80 MHz...1 GHz)	
	Immunity to fast transients in bursts, conforming to IEC 1000-4-4		Level III (direct 2 kV / capacitive connecting clip 1 kV)	
	Immunity to surges on the power supply conforming to IEC 1000-4-5		Level III (common mode 2 kV / differential mode 1 kV)	
	Immunity to radio frequency interference in common mode conforming to ENV 50141 (IEC 1000-4-6)		Level III (10 V rms : 0.15...80 MHz)	
	Immunity to voltage dips and breaks conforming to IEC 1000-4-11			30 % / 10 ms
				60 % / 100 ms >
	Radiated and mains conducted disturbance conforming to EN 55022 (EN 55011 Group 1)			Class B
Mounting method	Symmetrical mounting rail (EN 50022)	mm	35	
Clamping capacity	Without cable end	mm ²	2 x 2.5	
	With cable end	mm ²	2 x 1.5	
Spring terminals, 2 terminals per connection point	Flexible cable	mm ²	1.5	
	Solid cable	mm ²	2.5	
Enclosure material			Self-extinguishing	

Zelio Time - timing relays

Modular relays, solid state output
width 17.5 mm

Solid state output

- Multifunction or single function
- Multi-range (7 switchable ranges)
- Multivoltage
- Solid state output : 0.7 A - 250 V (0.5 A UL)
- Screw terminals
- State indication by 1 LED

Function diagrams

Function A

Delay on energisation

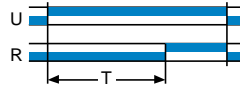

Function H

Timing on energisation
Pulse-on energisation



Function Li

Asymmetrical recycler
Pulse start

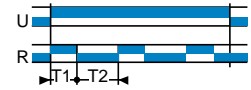

Function B

Timing on impulse, one shot

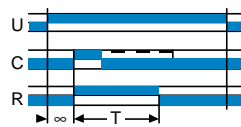

Function L

Asymmetrical recycler
Start after pause

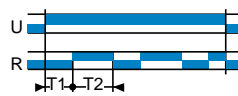

Function Di

Symmetrical flasher, start
with output in operating
position

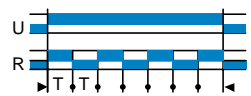

References

560847



560848



Connection	Screw terminals	●	●
Functions		Multifunction A - At - B - C - H - Ht - Di - D - Ac - Bw	Single function A
Timing ranges	7 ranges	1 s - 10 s - 1 min - 10 min - 1 h - 10 h - 100 h	
Rated current		0.7 A	0.7 A
Voltages	24...240 V ~ 50/60 Hz	RE 88 826 004	-
	24...240 V ~/∞ 50/60 Hz	-	RE 88 826 014
Weight (kg)		0.060	0.060

Dimensions and connection schemes

Dimensions

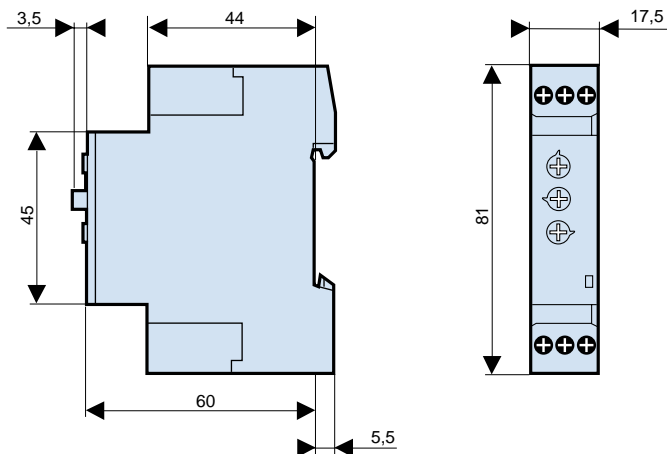

Function C
Off-delay, with control contact

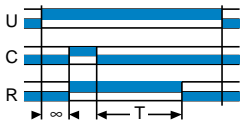

Function At
Timing on energisation with memory

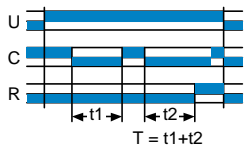

Function Ht
Delay on energisation with memory

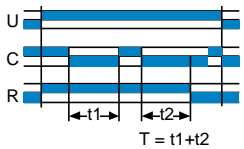

Function D
Symmetrical flasher, start with output in rest position

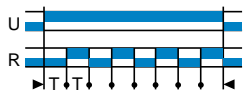

Function Bw
Pulse output (adjustable)

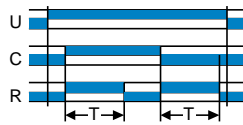

Function Ac
Timing after closing/opening of control contact

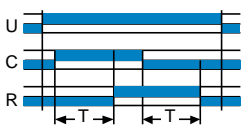

Single function	Dual function
H	Li - L
1 s - 10 s - 1 min - 10 min - 1 h - 10 h - 100 h	
0.7 A	0.7 A
RE 88 826 044	RE 88 826 054
-	-
0.060	0.060

Connection schemes

Functions A, H

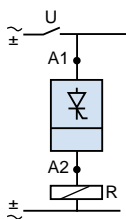

Function U

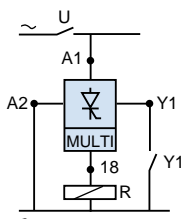

Functions L, Li

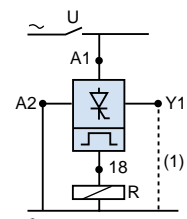

(1) Link A2-Y1 for function L only.

Presentation



The RE9 range of relays is designed for simple, repetitive applications with short and intensive cycles because their solid state output provides very high electrical durability.

Each relay has a single timing range.

Each relay has a wide voltage range from 24 to 240 V.
The range comprises 9 references with 3 model types :

- RE9-TA : function A
- RE9-RA : function C,
- RE9-MS : multifunction A, H, L, Li.

These products have a transparent, hinged flap on their front face to avoid any accidental alteration of the settings. This flap can be directly sealed.

Environment

Conforming to standards			IEC 61812-1, EN 61812-1
Approvals			CSA, GL pending, UL
CE marking			Zelio Time timing relays conform to European regulations relating to CE marking
Ambient air temperature around the device	Storage	°C	- 40...+ 85
	Operation	°C	- 20...+ 60
Permissible relative humidity range	Conforming to IEC 60721-3-3		15...85 % Environmental class 3K3
Vibration resistance	Conforming to IEC 6068-2-6, 10 to 55 Hz		a = 0.35 ms
Shock resistance	Conforming to IEC 6068-2-27		15 gn - 11 ms
Degree of protection	Casing		IP 50
	Terminals		IP 20
Degree of pollution	Conforming to IEC 60664-1		3
Overvoltage category	Conforming to IEC 60664-1		III
Rated insulation voltage	Conforming to IEC	V	250
	Conforming to CSA	V	300
Test voltage for insulation tests	Dielectric test	kV	2.5
	Shock wave	kV	4.8
Voltage limits	Power supply circuit		0.85...1.1 Uc
Frequency limits	Power supply circuit	Hz	50/60 ± 5 %
Disconnection value	Power supply circuit		> 0.1 Uc
Mounting position without derating	In relation to normal vertical mounting plane		Any position
Connection Maximum c.s.a.	Flexible cable without cable end	mm ²	2 x 2.5
	Flexible cable with cable end	mm ²	2 x 1.5
Tightening torque		N.m	0.6...1.1

Immunity to electromagnetic interference (EMC) (Application class 2 conforming to EN 61812-1)

Electrostatic discharge	Conforming to IEC 61000-2-6		Level 3 (6 kV contact, 8 kV air)
Electromagnetic fields	Conforming to IEC 61000-4-3		Level 3 (10 V/m)
Fast transients	Conforming to IEC 61000-4-4		Level 3 (2 kV)
Shock waves	Conforming to IEC 61000-4-5		Level 3 (2 kV)
Radiated and conducted emissions	CISPR11		Group 1 class A
	CISPR22		Class A

Timing relay type			RE9-TA On-delay	RE9-RA Off-delay	RE9-MS Multifunction
Supply characteristics					
Supply voltage		V	$\approx 24 \dots 240$	$\sim 24 \dots 240$	$\approx 24 \dots 240$. See page 28467/2
Voltage limits	Power supply circuit		0.85...1.1 Un		
Frequency		Hz	50...60 \pm 5 %		
Control contact	Mechanical only		In series	Between Y2 and A2	In series
Max. length of connecting cable	From contact to RE9	m	–	20	–
Control input consumption	Input Y2	mA	–	5	–
Timing characteristics					
Setting accuracy			< \pm 20 %		
Repeat accuracy			< 1 %		
Minimum reset time	After the time delay period	ms	100		
Minimum switching time time		ms	–	40	–
Maximum immunity to microbreaks	During the time delay period	ms	100	2	70
	After the time delay period	ms	2	–	2
Temperature drift			\leq 0.1 % per degree centigrade		
Switching characteristics (solid state type)					
Maximum continuous current	At ambient temperature : 20 °C	A	0.7 (minimum 10 mA)		
Maximum overload current	VDE 0435 part. 303, 4.8.3/Class II	A	15 for 10 ms		
Maximum voltage drop	Closed state	V	A 0.7 A : 3		
Leakage current	Open state	mA	\leq 6	\leq 1	\leq 6
Maximum dissipated power		W	2.5	4	2.5
Derating	For temperature > 20 °C	mA	Without		
Electrical durability	In millions of operating cycles		> 100		

Output 1 C/O contact

Function diagrams

Function A

Delay on energisation

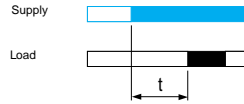

Function C

Off-delay

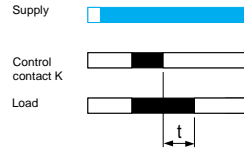

Function H

Timing on energisation
Pulse-on energisation

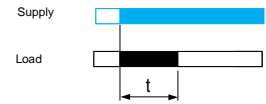

Function Di

Symmetrical flasher, start
with output in operating
position



Function D

Symmetrical flasher, start
with output in rest
position

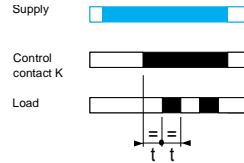

References



Functions		A	C	A, H, D, Di
Voltages	\equiv or \sim 24...240 V	●	—	● (A)
	\sim 24...240 V	—	●	● (H, D, Di)
Timing ranges	0.1 s...10 s	RE9 TA11MW	RE9 RA11MW7	RE9 MS21MW
	0.3 s...30 s	RE9 TA31MW	RE9 RA31MW7	—
	3 s...300 s	RE9 TA21MW	RE9 RA21MW7	RE9 MS21MW
	40 s...60 min	RE9 TA51MW	RE9 RA51MW7	—
Weight (kg)		0.110	0.110	0.110

Dimensions

Rail mounting

Screw fixing

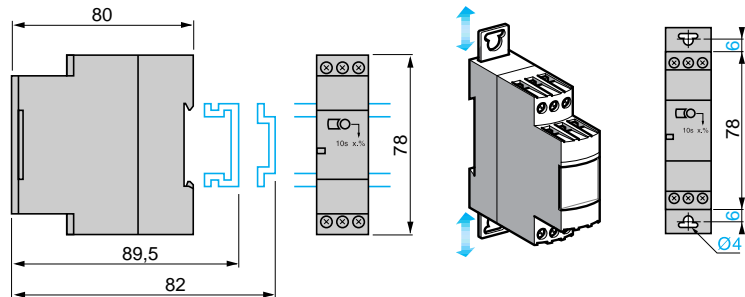

Terminal blocks

RE9 TA

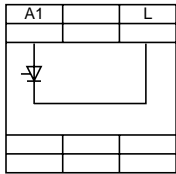

RE9 RA

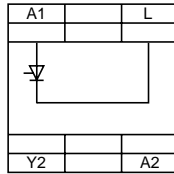

RE9 MS

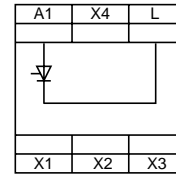

Recommended application schemes

RE9 TA

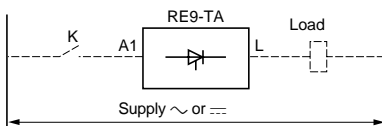

The timing relay is placed in series, with the load whose de-energisation is to be delayed on one side and switch K on the other side. The mains supply may be a.c. or d.c. and the voltage may be between 24 V and 240 V. See function diagram on page opposite.

RE9 RA

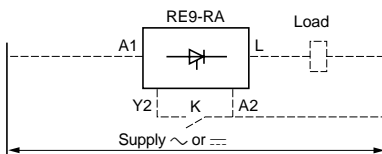

The timing relay is placed in series with the load whose de-energisation is to be delayed. Switch K is connected to terminals Y2 and A2 of the timing relay, and terminal A2 is connected to the mains supply, as indicated in the diagram opposite. The device is operated from an a.c. mains supply whose voltage is between 24 V and 240 V. See function diagram on page opposite.

RE9 MS

Delay on energisation Function A

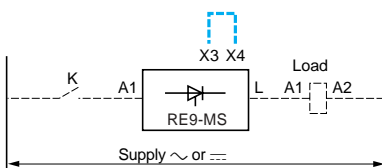

Pulse-on energisation Function H

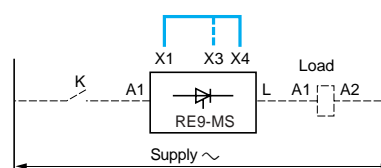

Selection of the timing range

X3-X4 not linked : range 3 s...300 s
(factory configuration)

X3-X4 linked : range 0.1 s...10 s

Link to be made between terminals X1 and X4

Symmetrical flasher Start with output in the rest position Function D

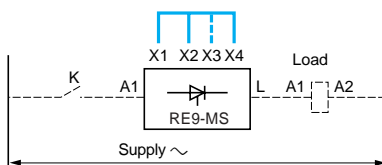

Symmetrical flasher Start with output in the operating position Function Di

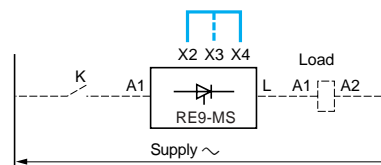

Link to be made between terminals X2 and X4 on one side and between X1 and X2 on the other side

Link to be made between terminals X1 and X4

Note : For supply voltages greater than 30 V, the rated voltage of the load is equal to the supply voltage. For a supply voltage of 24 V, the voltage drop within the RE9 relay must be taken into account (about 3 V); a coil with a nominal voltage of 21 V must therefore be selected for the load.

Timing characteristics

Repeat accuracy (with constant parameters)	Conforming to IEC 1812-1		± 0.5 %
Drift	Temperature		± 0.05 % / °C
	Voltage		± 0.2 % / V
Setting accuracy at full scale	Conforming to IEC 1812-1		± 10 % at 25 °C
Minimum duration of control impulse	Typical	ms	30
	Typical under load	ms	100
Maximum reset time by de-energisation	Typical	ms	100
Immunity time to microbreaks	Typical	ms	> 10



Supply characteristics

Multivoltage supply			Depending on version, see pages 28503/4 and 28503/5	
Frequency		Hz	50/60	
Operating range			85...110 % of Un	
On-load factor			100 %	
Maximum power consumption	Depending on model	--- 24 V	W	0.6
		--- 240 V	W	1.5
		~ 240 V	VA	32

Output characteristics

Output type			Relay, 1 C/O contact, AgNi (cadmium-free)
Breaking capacity			~ 2000 VA, --- 80 W
Maximum breaking current		A	~ 8, --- 8
Minimum breaking current		mA	10 / --- 5 V
Maximum switching voltage		V	~ / --- 250
Electrical life			10 ⁵ operations 8 A 250 V resistive
Mechanical life			5 x 10 ⁶ operations
Dielectric strength	Conforming to IEC 1812-1	kV	2.5/1min/1 mA/50 Hz
Impulse voltage	Conforming to IEC 664-1, IEC 1812-1	kV	5, wave 1.2/50 µs

Display characteristics

State indication by 1 LED	Green		<p>Operating status indication</p> <p> Pulsing : relay energised, no timing in progress (except Di-D and Li-L)</p> <p> Flashing : timing in progress</p> <p> On steady : relay energised, no timing in progress</p>
----------------------------------	-------	--	--

Input characteristics

Input type		V	<p>Volt-free contact (no potential)</p> <p>Control possible by 3-wire sensor with PNP output, maximum residual voltage : 0.4 V whatever the supply voltage of the relay</p>
-------------------	--	----------	---

Zelio Time - timing relays

Modular relays, relay output
width 17.5 mm

General characteristics			
Conforming to standards			IEC 1812-1, EN 50081-1/2, EN 50082-1/2, LV directives (73/23/EEC + 93/68/EEC (CE marking) + EMC (89/336/EEC + IEC 669-2-3)
Approvals			c UL us, CSA, GL except RE 88 826 503
Temperature limits	Operation	°C	- 20...+ 60
	Storage	°C	- 30...+ 60
Creepage distance and clearance	Conforming to IEC 60664-1	kV	4 kV/3
Degree of protection conforming to IEC 529	Terminal block		IP 20
	Enclosure		IP 40
	Panel-mounted		IP 50
Vibration resistance	Conforming to IEC 68-2-6		f = 10...55 Hz A = 0.35 mm
Relative humidity without condensation	Conforming to IEC 68-2-3		93 %
Electromagnetic compatibility	Immunity to electrostatic discharge, conforming to IEC 1000-42		Level III (Air 8 kV/Contact 6 kV)
	Immunity to electromagnetic fields, conforming to ENV 50140/204 (IEC 1000-4-3)		Level III 10 V/m : (80 MHz...1 GHz)
	Immunity to fast transients in bursts, conforming to IEC 1000-4-4		Level III (direct 2 kV / capacitive connecting clip 1 kV)
	Immunity to surges on the power supply, conforming to IEC 1000-4-5		Level III (common mode 2 kV / differential mode 1 kV)
	Immunity to radio frequency interference in common mode conforming to ENV 50141 (IEC 1000-4-6)		Level III (10 V rms : 0.15...80 MHz)
	Immunity to voltage dips and breaks conforming to IEC 1000-4-11		30 % / 10 ms 60 % / 100 ms > 95 % / 5 s
	Radiated and mains conducted disturbance conforming to EN 55022 (EN 55011 Group 1)		Class B
Mounting method	Symmetrical mounting rail (EN 50022)	mm	35
Clamping capacity	Without cable end	mm ²	2 x 2.5
	With cable end	mm ²	2 x 1.5
Spring terminals, 2 terminals per connection point	Flexible cable	mm ²	1.5
	Solid cable	mm ²	2.5
Enclosure material			Self-extinguishing

Output 1 C/O contact

- Multifunction or single function
- Multi-range (7 switchable ranges)
- Multivoltage
- 1 relay output : 8 A - 250 V (10 A UL)
- Screw or spring terminals
- State indication by 1 LED
- Option of supplying a load in parallel
- 3-wire sensor control option

Function diagrams

Function A

Delay on energisation

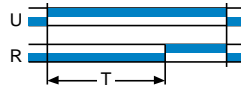

Function H

Timing on energisation
Pulse-on energisation



Function Li

Asymmetrical recycler
Pulse start

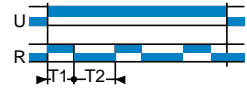

Function B

Timing on impulse, one shot

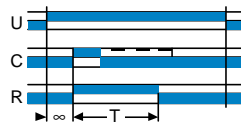

Function L

Asymmetrical recycler
Start after pause

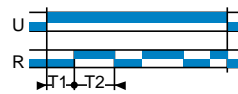

Function Di

Symmetrical flasher, start
with output in operating
position

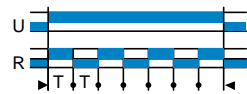

References



Connection	Screw terminals	●	●	●
	Spring terminals	—	—	—
Functions		Multifunction	Dual function	Single function
		A - At - B - C - H - Ht - Di - D Ac - Bw	A - At	B
Timing ranges	7 ranges	1 s - 10 s - 1 min - 10 min - 1 h - 10 h - 100 h		
Rated current		8 A	8 A	8 A
Voltages	$\equiv 24\text{ V} / \sim 24\dots240\text{ V}$	RE 88 826 105	RE 88 826 115	RE 88 826 125
	$\sim/\equiv 12\dots240\text{ V}$	—	—	—
Weight (kg)		0.060	0.060	0.060

Dimensions and connection schemes

Dimensions

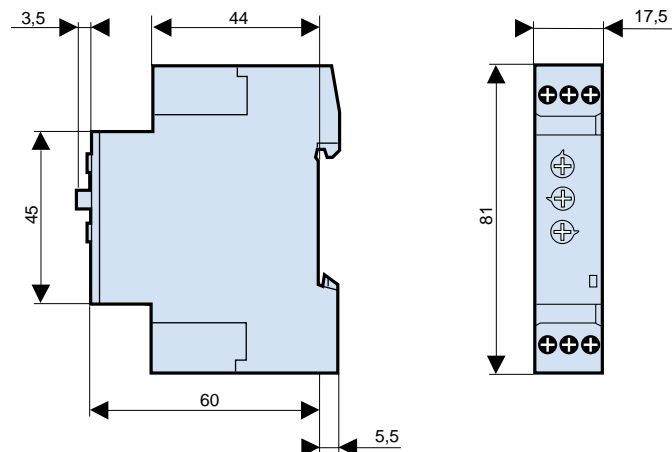

Function C
Off-delay, with control contact

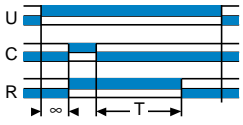

Function At
Timing on energisation with memory

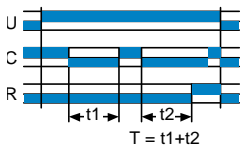

Function Ht
Delay on energisation with memory

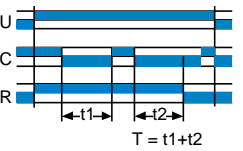

Function D
Symmetrical flasher, start with output in rest position

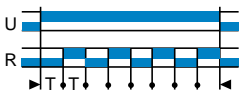

Function Bw
Pulse output (adjustable)

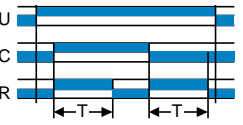

Function Ac
Timing after closing/opening of control contact

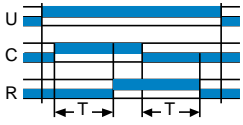

•	•	•	•	•
–	–	–	–	–
Single function	Dual function	Dual function	Multifunction	Multifunction
C	H - Ht	Li - L	A - At - B - C - H - Ht - Di - D - Ac - Bw	A - At - B - C - H - Ht - Di - D - Ac - Bw
1 s - 10 s - 1 min - 10 min - 1 h - 10 h - 100 h				
8 A	8 A	8 A	8 A	8 A
RE 88 826 135	RE 88 826 145	RE 88 826 155	–	–
–	–	–	RE 88 826 103	RE 88 826 503
0.060	0.060	0.060	0.060	0.060

Connections
All functions except L and Li

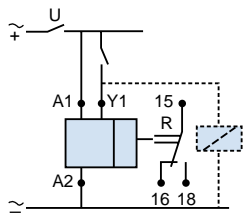

Functions L and Li

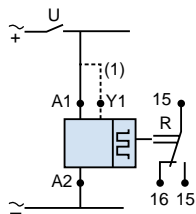

(1) Link A1-Y1 for function L only.

Timing characteristics

Repeat accuracy (with constant parameters)	Conforming to IEC 1812-1		± 0.5 %
Drift	Temperature		± 0.05 % / °C
	Voltage		± 0.2 % / V
Full scale setting accuracy	Conforming to IEC 1812-1		± 10 % at 25 °C
Minimum duration of control impulse	Typical	ms	30
	Typical under load	ms	100
Maximum reset time by de-energisation	Typical	ms	100
Immunity time to microbreaks	Typical	ms	> 10



Supply characteristics

Multivoltage supply			Depending on version, see pages 28504/4 and 28504/5	
Frequency		Hz	50/60	
Operating range			85...110 % Un (85...120 Un for \sim/\equiv 12 V)	
On-load factor			100 %	
Maximum power consumption	Depending on model	\equiv 24 V	W	0.6
		\equiv 240 V	W	1.5
		\sim 240 V	VA	32

Output characteristics

Output type			Relay, C/O contact AgNi (cadmium free)
Breaking capacity			\sim 2000 VA, \equiv 80 W
Maximum breaking current		A	\sim 8, \equiv 8
Minimum breaking current		mA	10 / \equiv 5 V
Maximum switching voltage		V	\sim/\equiv 250
Electrical life			10 ⁵ operations 8 A 250 V resistive
Mechanical life			5 x 10 ⁶ operations
Dielectric strength	Conforming to IEC 1812-1	kV	2.5/1min/1 mA/50 Hz
Impulse voltage	Conforming to IEC 664-1, IEC 1812-1	kV	5, wave 1.2/50 μ s

Display characteristics

State indication by 2 LEDs	Green		Operating state indication green LED  Pulsing : relay energised, no timing in progress (except Di-D and Li-L)  Flashing : timing in progress  On steady : relay energised, no timing in progress
	Yellow		On-delay relay

Input characteristics

Input type		V	Volt-free contact (no potential) Control possible by 3-wire sensor with PNP output, maximum residual voltage : 0.4 V whatever the supply voltage of the timer
------------	--	---	--

General characteristics

Conforming to standards			IEC 1812-1, EN 50081-1/2, EN 50082-1/2, LV directives (73/23/EEC + 93/68/EEC (CE marking) + EMC (89/336/EEC + IEC 669-2-3)	
Approvals			c UL us, CSA, GL except RE 88 865 503	
Temperature limits	Operation	°C	- 20...+ 60	
	Storage	°C	- 30...+ 60	
Creepage distance and clearance	Conforming to IEC 60664-1	kV	4 kV/3	
Degree of protection conforming to IEC 529	Terminal block		IP 20	
	Enclosure		IP 40	
	Front panel		IP 50	
Vibration resistance	Conforming to IEC 68-2-6		f = 10...55 Hz A = 0.35 mm	
Relative humidity without condensation	Conforming to IEC 68-2-3		93 %	
Electromagnetic compatibility	Immunity to electrostatic discharge, conforming to IEC 1000-42		Level III (Air 8 kV/Contact 6 kV)	
	Immunity to electromagnetic fields, conforming to ENV 50140/204 (IEC 1000-4-3)		Level III 10 V/m : (80 MHz...1 GHz)	
	Immunity to fast transients in bursts conforming to IEC 1000-4-4		Level III (direct 2 kV / capacitive connecting clip 1 kV)	
	Immunity to surges on the power supply, conforming to IEC 1000-4-5		Level III (common mode 2 kV / differential mode 1 kV)	
	Immunity to radio frequency interference in common mode conforming to ENV 50141 (IEC 1000-4-6)		Level III (10 V rms : 0.15...80 MHz)	
	Immunity to voltage dips and breaks IEC 1000-4-11			30 % / 10 ms
				60 % / 100 ms >
			95 % / 5 s	
Radiated and mains conducted disturbance conforming to EN 55022 (EN 55011 Group 1)			Class B	
Fixing	Symmetrical mounting rail (EN 50022)	mm	35	
Clamping capacity	Without cable end	mm²	2 x 2.5	
	With cable end	mm²	2 x 1.5	
Spring terminals, 2 terminals per connection point	Flexible cable	mm²	1.5	
	Solid cable	mm²	2.5	
Enclosure material			Self-extinguishing	

Zelio Time - timing relays

Industrial multifunction relays,
relay output, width 22.5 mm

Relay output, 1 C/O contact

- Multifunction or single function
- Multi-range (7 switchable ranges)
- Multivoltage
- 1 relay output : 8 A - 250 V (10 A UL)
- Screw or spring terminals
- State indication by 1 LED
- Option of supplying a load in parallel
- 3-wire sensor control option

Function diagrams

Function A

Delay on energisation

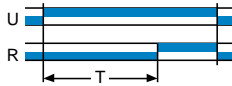

Function H

Timing on energisation



Function Li

Asymmetrical recycler
Pulse start

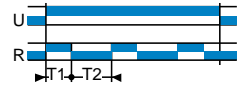

Function B

Timing on impulse, one shot

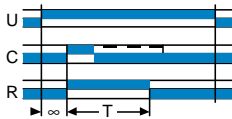

Function L

Asymmetrical recycler
Start after pause

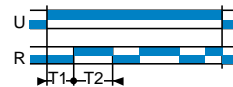

Function Di

Flashing relay
Pulse start

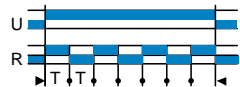

References



Connection	Screw terminals	●	●	●
	Spring terminals	-	-	-
Functions		Multifunction	Dual function	Single function
		A - At - B - C - H - Ht - Di - D Ac - Bw	A - At	B
Timing ranges	7 ranges	1 s - 10 s - 1 min - 10 min - 1 h - 10 h - 100 h		
Selectable interswitching time		-	-	-
Rated current		8 A	8 A	8 A
Voltages	$\overline{\text{=}}$ 24 V / \sim 24...240 V	RE 88 865 105	RE 88 865 115	RE 88 865 125
	$\sim/\overline{\text{=}}$ 12 V	-	-	-
	$\sim/\overline{\text{=}}$ 12...240 V	-	-	-
	\sim 230 / 380 V	-	-	-
Weight (kg)		0.090	0.090	0.090

Dimensions and connection schemes

Dimensions

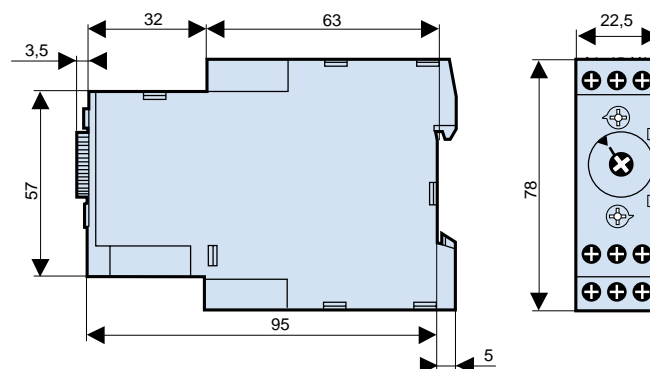

Function C

Off-delay

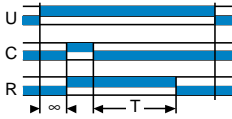

Function At

Timing on energisation with memory

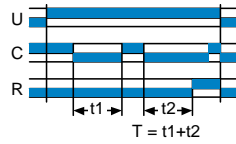

Function Ht

Delay on energisation with memory

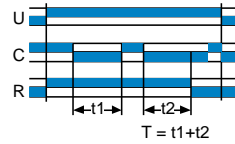

Function D

Flashing relay
Start after pause

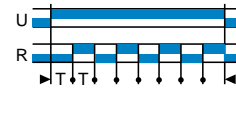

Function Bw

Pulse output (adjustable)

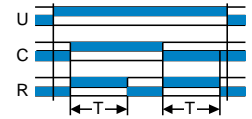

Function Ac

Timing after closing/opening of control contact



Function Q

Star-delta starting



●	●	●	●	●	●	●
Single function	Dual function	Dual function	Single function	Single function	Multifunction	Multifunction
C	H - Ht	Li - L	Q	Q	A - At - B - C - H - Ht - Di - D - Ac - Bw	A - At - B - C - H - Ht - Di - D - Ac - Bw
1 s - 10 s - 1 min - 10 min - 1 h - 10 h - 100 h	-	-	20 - 40 - 60 - 80 - 100 - 120 - 140 ms	20 - 40 - 60 - 80 - 100 - 120 - 140 ms	-	-
8 A	8 A	8 A	8 A	8 A	8 A	8 A
RE 88 865 135	RE 88 865 145	RE 88 865 155	RE 88 865 175	-	-	-
-	-	-	-	-	RE 88 865 103	RE 88 865 503
-	-	-	-	RE 88 865 176	-	-
0.090	0.090	0.090	0.090	0.090	0.090	0.090

Connection schemes

All functions except L and Li

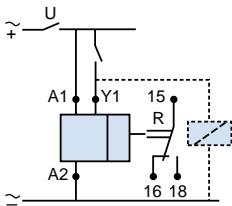

Functions L and Li

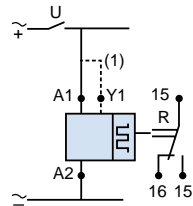

Function Q

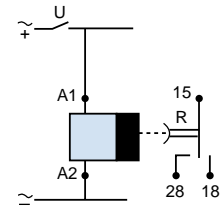

(1) Link A1-Y1 for function L only.

Zelio Time - timing relays

Industrial multifunction relays,
relay output, width 22.5 mm

Timing characteristics

Repeat accuracy (with constant parameters)	Conforming to IEC 1812-1		± 0.5 %
Drift	Temperature		± 0.05 % / °C
	Voltage		± 0.2 % / V
Full scale setting accuracy	Conforming to IEC 1812-1		± 10 % at 25 °C
Minimum duration of control impulse	Typical	ms	30
	Typical under load	ms	100
Maximum reset time by de-energisation	Typical	ms	100
Immunity time to microbreaks	Typical	ms	> 10



Supply characteristics

Multivoltage supply			Depending on version, see pages 28508/4 and 28508/5	
Frequency		Hz	50/60	
Operating range			85...110 % Un (85...120 Un for \sim/\equiv 12 V)	
On-load factor			100 %	
Maximum power consumption	Depending on model	\equiv 24 V	W	0.6
		\equiv 240 V	W	1.5
		\sim 240 V	VA	32

Output characteristics

Output type			Relay, C/O contacts, AgNi (cadmium-free)
Breaking capacity			\sim 2000 VA, \equiv 80 W
Maximum breaking current		A	\sim 8, \equiv 8
Minimum breaking current		mA	10 / \equiv 5 V
Maximum switching voltage		V	\sim/\equiv 250
Electrical life			10 ⁵ operations 8 A 250 V resistive
Mechanical life			5 x 10 ⁶ operations
Dielectric strength	Conforming to IEC 1812-1	kV	2.5/1min/1 mA/50 Hz
Impulse voltage	Conforming to IEC 664-1, IEC 1812-1	kV	5, wave 1.2/50 μ s

Display characteristics

State indication by 2 LEDs	Green		Operating state indication green LED  Pulsing : relay energised, no timing in progress (except Di-D and Li-L)  Flashing : timing in progress  On steady : relay energised, no timing in progress
	Yellow		On-delay relay

Input characteristics

Input type		V	Volt-free contact (no potential) Control possible by 3-wire sensor with PNP output, maximum residual voltage : 0.4 V whatever the supply voltage of the timer
------------	--	---	--

General characteristics

Conforming to standards			IEC 1812-1, EN 50081-1/2, EN 50082-1/2, LV directives (73/23/EEC + 93/68/EEC (CE marking) + EMC (89/336/EEC + IEC 669-2-3)	
Approvals			c UL us, CSA GL except RE 88 865 265	
Temperature limits	Operation	°C	- 20...+ 60	
	Storage	°C	- 30...+ 60	
Creepage distance and clearance	Conforming to IEC 60664-1	kV	4 kV/3	
Degree of protection conforming to IEC 529	Terminal block		IP 20	
	Enclosure		IP 40	
	Front panel		IP 50 except RE 88 865 265	
Vibration resistance	Conforming to IEC 68-2-6		f = 10...55 Hz A = 0.35 mm	
Relative humidity without condensation	Conforming to IEC 68-2-3		93 %	
Electromagnetic compatibility	Immunity to electrostatic discharge, conforming to IEC 1000-42		Level III (Air 8 kV/Contact 6 kV)	
	Immunity to electromagnetic fields, conforming to ENV 50140/204 (IEC 1000-4-3)		Level III 10 V/m : (80 MHz...1 GHz)	
	Immunity to fast transients in bursts conforming to IEC 1000-4-4		Level III (direct 2 kV / capacitive connecting clip 1 kV)	
	Immunity to surges on the power supply, conforming to IEC 1000-4-5		Level III (common mode 2 kV / differential mode 1 kV)	
	Immunity to radio frequency interference in common mode conforming to ENV 50141 (IEC 1000-4-6)		Level III (10 V rms : 0.15...80 MHz)	
	Immunity to voltage dips and breaks, conforming to IEC 1000-4-11			30 % / 10 ms
				60 % / 100 ms >
			95 % / 5 s	
Radiated and mains conducted disturbance conforming to EN 55022 (EN 55011 Group 1)			Class B	
Fixing	Symmetrical mounting rail (EN 50022)	mm	35	
Clamping capacity	Without cable end	mm²	2 x 2.5	
	With cable end	mm²	2 x 1.5	
Enclosure material			Self-extinguishing	
Weight : 22.5 mm enclosure		g	90	

Zelio Time - timing relays

Industrial multifunction relays, relay output, width 22.5 mm

Relay output, 2 C/O contacts

- Multifunction or single function
- Multi-range (7 switchable ranges)
- Multivoltage
- 2 relay outputs : 8 A - 250 V (10 A UL) of which 1 instantaneous
- Screw terminals
- State indication by 1 LED
- Option of supplying a load in parallel
- 3-wire sensor control option

Function diagrams

Function A

Delay on energisation,
2 timed contacts or
2 timed contacts, 1 of which
convertible to instantaneous

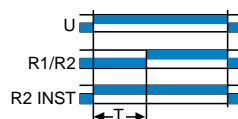

Function C

Off-delay
2 timed contacts or
2 timed contacts, 1 of which
convertible to instantaneous

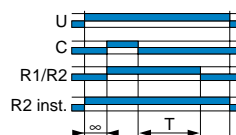

Function Ac

Timing after closing/opening
of control contact
2 timed contacts or
2 timed contacts, 1 of which
convertible to instantaneous

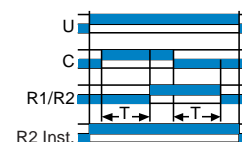

Function B

Timing on impulse, one shot
2 timed contacts or
2 timed contacts, 1 of which
convertible to instantaneous

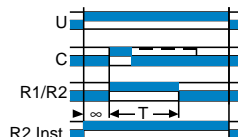

Function Ht

Delay on energisation with
memory
2 timed contacts or
2 timed contacts, 1 of which
convertible to instantaneous

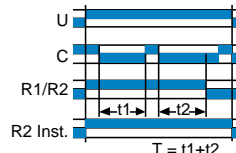

Function Di

Flashing relay
Pulse start
2 timed contacts or
2 timed contacts, 1 of which
convertible to instantaneous

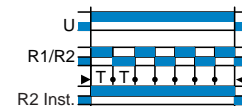

References



Connection	Screw terminals	●	●
Functions		Multifunction A - At - B - C - H - Ht - Di - D - Ac - Bw	Dual function A - At
Timing ranges	7 ranges 4 ranges	1 s - 10 s - 1 min - 10 min - 1 h - 10 h - 100 h	-
Relay output		2 timed contacts, 1 convertible to instantaneous	2 timed contacts
Rated current		8 A	8 A
Voltages	$\frac{\square\square}{\sim}$ 24 V / \sim 24...240 V $\sim/\frac{\square\square}{\sim}$ 12 V	RE 88 865 305	RE 88 865 215
Weight (kg)		0.090	0.090

Dimensions and connection schemes

Dimensions

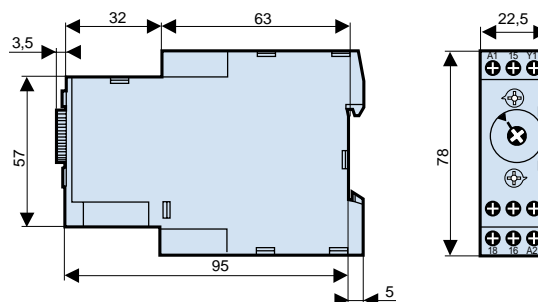

Function K

Delay on de-energisation
True off-delay
(without auxiliary supply)
2 timed contacts

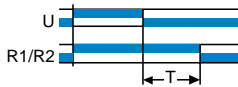

Function At

Timing on energisation
with memory
2 timed contacts or
2 timed contacts, 1 of which
convertible to instantaneous

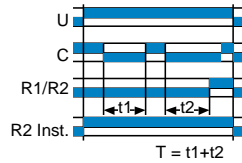

Function H

Timing on energisation
2 timed contacts or
2 timed contacts, 1 of which
convertible to instantaneous

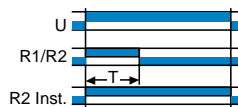

Function D

Flashing relay
Start after pause
2 timed contacts or
2 timed contacts, 1 of which
convertible to instantaneous

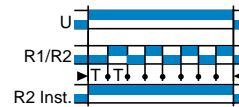

Function Bw

Pulse output (adjustable)
2 timed contacts or
2 timed contacts, 1 of which
convertible to instantaneous

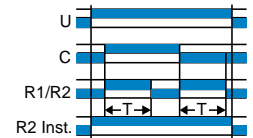

Single function

K
-
0.6 s - 2.5 s - 20 s - 160 s
2 timed contacts
8 A
RE 88 865 265
-
0.090

Multifunction

A - At - B - C - H - Ht - Di - D - Ac - Bw
1 s - 10 s - 1 min - 10 min - 1 h - 10 h - 100 h
-
2 timed contacts, 1 convertible to instantaneous
8 A
-
RE 88 865 303
0.090

Connection schemes

All functions except K

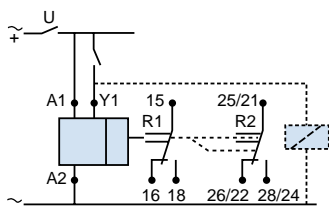

Function K

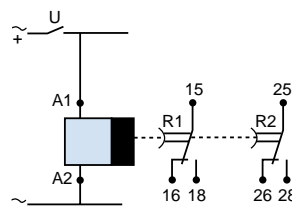

Presentation



The RE7 range of relays, with only 23 references, covers all timing applications.

These relays offer multi-range timing from 50 ms to 300 h.

They are multivoltage.

Three models combine several different functions : multifunction relays.

These products have a transparent, hinged flap on their front face to avoid any accidental alteration of the settings. This flap can be directly sealed.

Environment

Conforming to standards			IEC 61812-1, EN 61812-1
Approvals			CSA, GL pending, UL
CE marking			Zelio Time timing relays conform to European regulations relating to CE marking
Ambient air temperature around the device	Storage	°C	- 40...+ 85
	Operation	°C	- 20...+ 60
Permissible relative humidity range	Conforming to IEC 60721-3-3		15...85 % Environmental class 3K3
Vibration resistance	Conforming to IEC 6068-2-6, 10 to 55 Hz		a = 0.35 ms
Shock resistance	Conforming to IEC 6068-2-27		15 gn - 11 ms
Degree of protection	Casing		IP 50
	Terminals		IP 20
Degree of pollution	Conforming to IEC 60664-1		3
Overvoltage category	Conforming to IEC 60664-1		III
Rated insulation voltage Between contact circuit and power supply or between contact circuit and control inputs	Conforming to IEC	V	250
	Conforming to CSA	V	300
Test voltage for insulation tests d'isolement	Dielectric test	kV	2.5
	Shock wave	kV	4.8
Voltage limits	Power supply circuit		0.85...1.1 Uc
Frequency limits	Power supply circuit	Hz	50/60 ± 5 %
Disconnection value	Power supply circuit		> 0.1 Uc
Mounting position without derating	In relation to normal vertical mounting plane		Any position
Connection Maximum c.s.a.	Flexible cable without cable end	mm ²	2 x 2.5
	Flexible cable with cable end	mm ²	2 x 1.5
Tightening torque		N.m	0.6...1.1

Immunity to electromagnetic interference (EMC) (Application class 2 conforming to EN 61812-1)

Electrostatic discharge	Conforming to IEC 61000-2-6		Level 3 (6 kV contact, 8 kV air)
Electromagnetic fields	Conforming to IEC 61000-4-3		Level 3 (10 V/m)
Fast transients	Conforming to IEC 61000-4-4		Level 3 (2 kV)
Shock waves	Conforming to IEC 61000-4-5		Level 3 (2 kV)
Radiated and conducted emissions	CISPR11		Group 1 class A
	CISPR22		Class A

Consumption

Average consumption			~ 50/60 Hz					=			
			24 V	48 V	110 V	240 V		24 V	48 V	110 V	240 V
	RE7-●●11BU	VA	0.7	1.6	1.8	8.5	W	0.5	1.2	-	-
	RE7-●●12BU and RE7-●●13BU	VA	1.2	2	2.8	12.5	W	0.8	1.6	-	-
	RE7-●●●MW (1)	VA	2	2.5	3.2	6	W	2	1	3.2	2

(1) RE7-RB●●MW : current peak on energisation = 1 A / 30 ms.

Timing characteristics

Setting accuracy	As % of the full-scale value		± 10 %
Repeat accuracy			± 0.2 %
Influence of voltage	In the voltage range, 0.85...1.1 Un		< 0.2 %
Influence of temperature			< 0.07 %/°C
Immunity time to microbreaks		ms	3
Minimum control pulse		ms	20 (except RE7-RB1●MW : 1 s)
Reset time		ms	50

Output circuit characteristics

Maximum switching voltage		V	≈ 250
Mechanical durability	In millions of operating cycles		20
Current limit I _{th}		A	8 (except RE7-RB●●MW : 5 A)
Rated operational limits at 70 °C Conforming to IEC 60947-5-1/1991 and VDE 0660	AC-15	A	24 V 3
	DC-13	A	115 V 3 250 V 3 0.1
Minimum switching capacity			12 V/10 mA
Contact material			90/10 nickel silver (except RE7-RB●●MU : gold flashed silver alloy)

Remote control input characteristics

Maximum voltage	Applicable to inputs Y1Z2, X1Z2, X2Z2	V	60
Signal delivered by control inputs Y1Z2, X1Z2, X2Z2 △ No galvanic insulation between these inputs and the supply	Switching current	mA	< 1
	Maximum distance	m	50
	Compatibility		3/4-wire PNP and NPN Telemecanique sensors or other sensors without an internal load
Potentiometer for connection between terminals Z1Z2, Z3Z2	Type		Linear at ± 20 %
	Resistance	kΩ	47 ± 20 %
	Power	W	0.2
	Maximum distance	m	25 by shielded cable : shielding linked to terminal Z2

a.c. load

Curve 1

Electrical durability of contacts on resistive load in millions of operating cycles

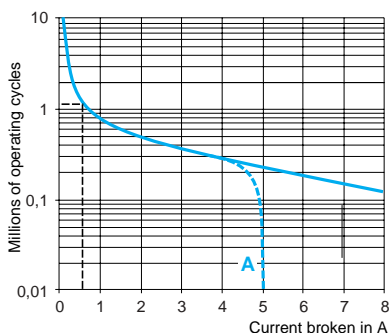

Curve 2

Reduction factor k for inductive loads (applies to values taken from the durability curve opposite)

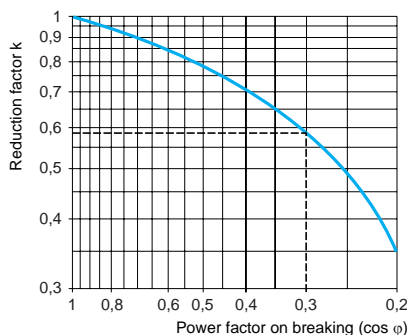

d.c. load

Load limit curve

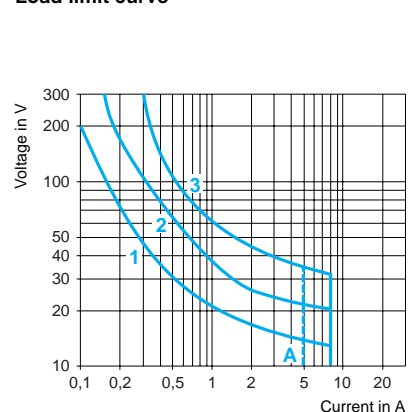

A RE7-RB●●MW

Example :

An LC1-F185 contactor supplied with 115 V/50 Hz for a consumption of 55 VA or a current consumption equal to 0.1 A and $\cos \varphi = 0.3$

For 0.1 A, curve 1 indicates a durability of approximately 1.5 million operating cycles.

As the load is inductive, it is necessary to apply a reduction coefficient k to this number of cycles as indicated by curve 2.

For $\cos \varphi = 0.3$: $k = 0.6$

The electrical durability therefore becomes :

$1.5 \cdot 10^6$ operating cycles \times 0.6 = 900 000 operating cycles

A RE7-RB●●MW

1 L/R = 20 ms

2 L/R with load protection diode

3 Resistive load

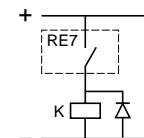

Output 2 C/O contacts
Multiple timing ranges

Function diagrams

Function A

Start on energisation

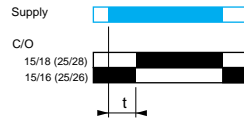

Function Ac

External control for start of time delay

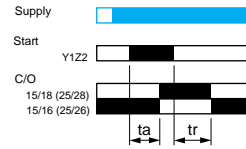

Function C

Off-delay with external control for start of time delay

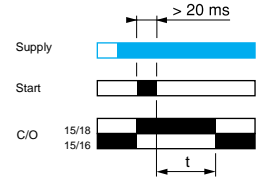

Function K

Off-delay

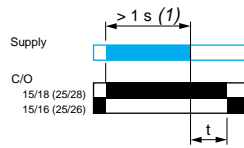

(1) If the device has been stored, de-energised, for more than a month, it must be energised for about 15 seconds in order to activate it. Subsequently, it only takes 1 second to start the time delay. Δ If this time is not complied with, the relay remains energised indefinitely.

References



Functions	A	Ac	C	K
Timing ranges	0.05 s...300 h 10 ranges	0.05 s...300 h 10 ranges	0.05 s...300 h 10 ranges	0.05 s...10 min 7 ranges
Voltages				
≡ or ~ 24 V	●	●	●	—
~ 110...240 V	●	●	●	—
~ or ≡ 42...48 V	●	●	●	—
≡ or ~ 24...240 V	—	—	—	●
References	RE7 TP13BU	RE7 MA13BU symmetrical	RE7 RL13BU low level contact	RE7 RB13MW
Weight (kg)	0.150	0.150	0.150	0.150

Dimensions and connection schemes

Dimensions

Rail mounting

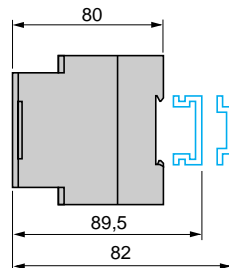

Screw fixing

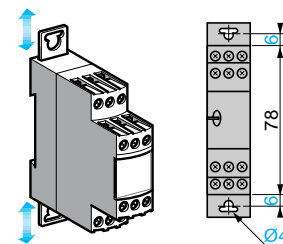

Function H
Pulse-on energisation.
Start on energisation

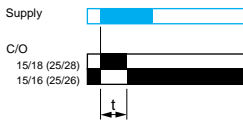

Function Hi
Start on opening of external control contact

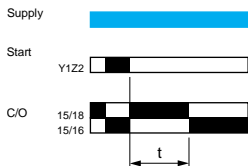

Function Qt
Timing relays for star-delta starters

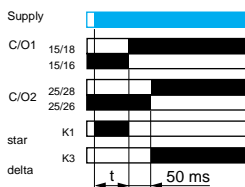

Function Qg
Timing relays for star-delta starters

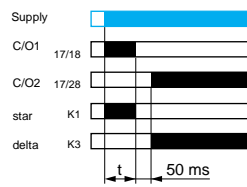

Function D
Symmetrical flasher, start with output in rest position

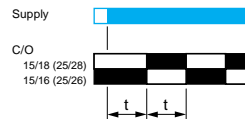

Function Di
Symmetrical flasher start with output in operating position

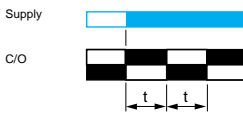

H	Hi	D	Qt	Qg	A, C, H, Hi, D, Di	A, C, H, Hi, D, Di, Qg, Qt
0.05 s...300 h 10 ranges	0.05 s...300 h 10 ranges	0.05 s...300 h 10 ranges	0.05 s...300 h 10 ranges	0.05 s...300 h 10 ranges	0.05 s...300 h 10 ranges	0.05 s...300 h 10 ranges
•	•	•	•	•	•	•
•	•	•	•	•	•	•
•	•	•	•	•	•	•
-	-	-	-	-	-	•
RE7 PP13BU	RE7 PD13BU	RE7 CP13BU	RE7 YA12BU	RE7 YR12BU	RE7 ML11BU	RE7 MY13BU
0.150	0.150	0.150	0.150	0.150	0.150	0.150

Connections

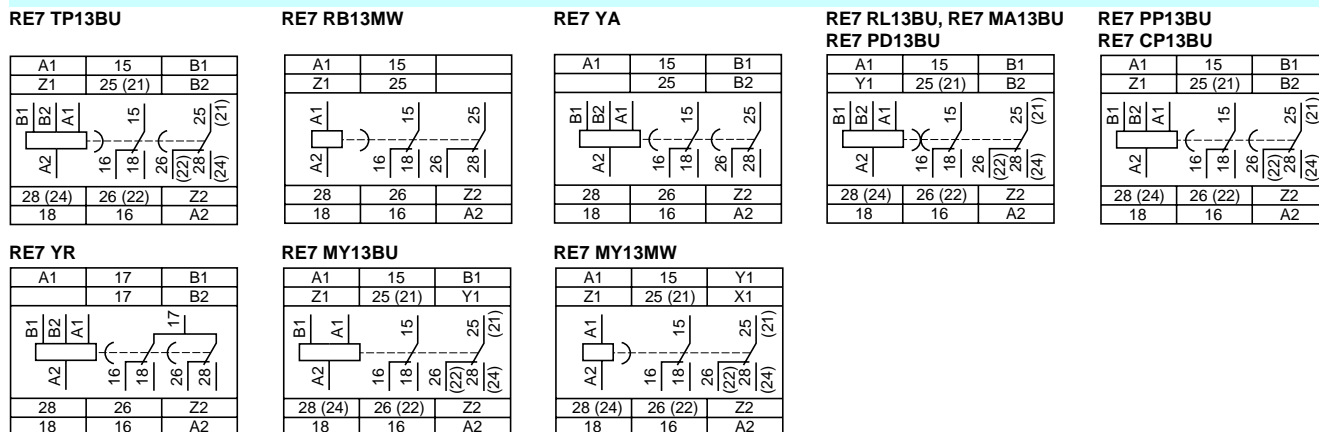

Recommended application schemes

RE7 TL, TM, TP, CL, CP, ML, MY

Start on energisation

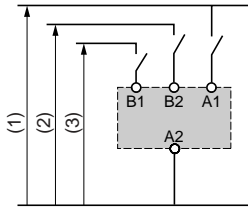

RE7 TM, MA, MV, RM, RL, PM, PD, ML, MY

Start by external control

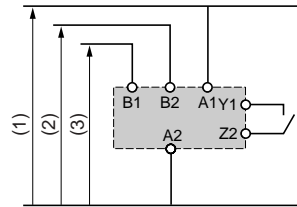

RE7 TM, PM, ML, MY

External control of partial stop

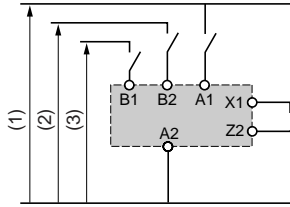

RE7 MA, MV, RA, RM

Start by external control

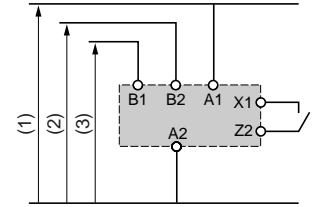

RE7 RB

Start on de-energisation

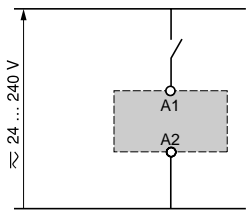

RE7 RA

Start by external control

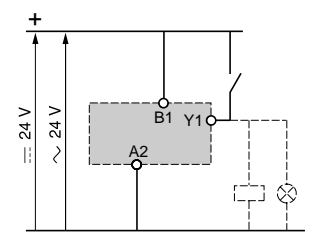
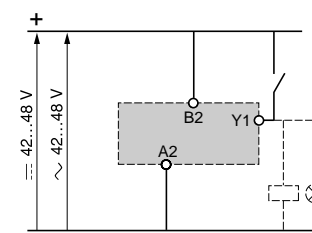
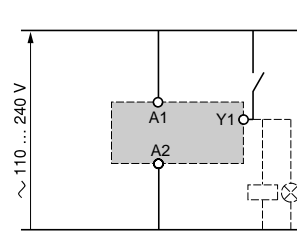

RE7 PP

Start on energisation

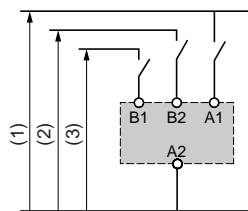

RE7 PE

Start on energisation

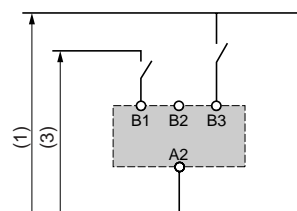

RE7 CV

Selection of starting phase

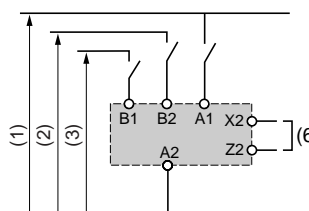

RE7 TM, TP, MA, RA, RM, PP, PM, ML, MY

Connection of potentiometer

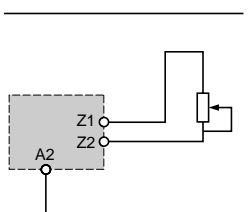

RE7 MV

Connection of potentiometers to asymmetrical timing relays

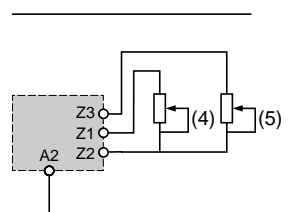

RE7 CV

Connection of potentiometers

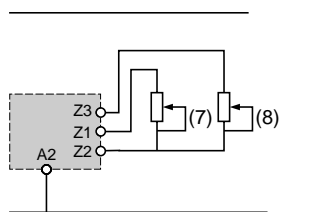

Connection precautions

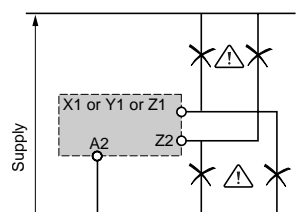

No galvanic isolation between supply terminals A1, A2, B1, B2 and control inputs X1, Y1, Z1, Z2.

(1) $\sim 110...240$ V except RE7 MY13MW : $\approx 24...240$ V.

(2) $\approx 12...48$ V

(3) ≈ 24 V

(4) Adjustment of the On-delay period

(5) Adjustment of the Off-delay period

(6) Start during the On-delay period : X2, Z2 linked. Start during the Off-delay period : X2, Z2 not linked.

(7) Off-delay adjustment (t_r) (contact 15/16 closed).

(8) On-delay adjustment (t_a) (contact 15/18 closed).

Recommended application schemes (continued)

Power scheme
RE7 YA12BU

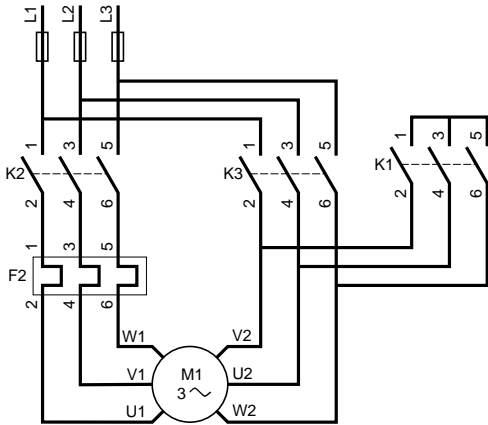

Control schemes

Star-delta function with double On-delay timing Qt

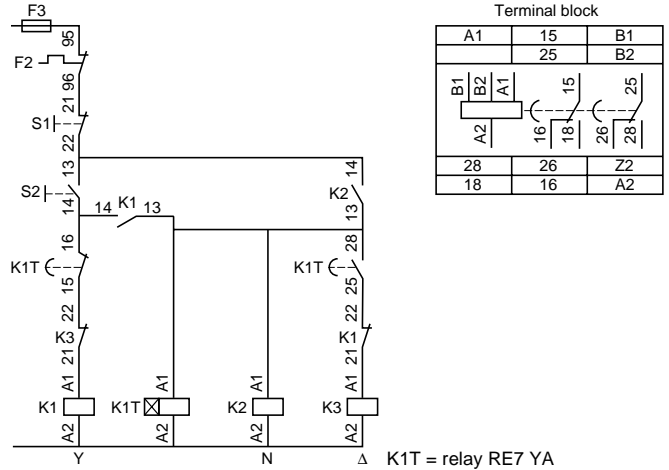

Power scheme
RE7 YR12BU

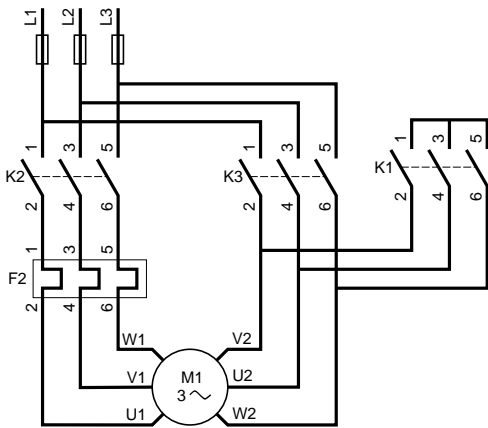

Control schemes

Star-delta function with contact for switching to star connection Q

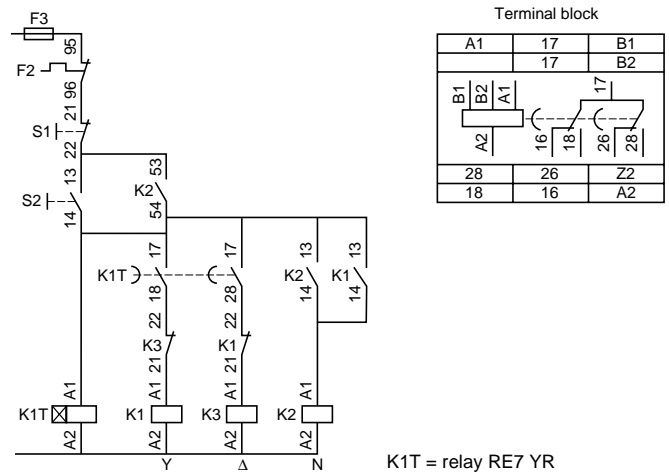

⚠ No galvanic isolation between supply terminals A1, A2, B1, B2 and supply terminal Z2. This terminal must therefore never be used (factory setting)

Control of several relays with a single external control contact

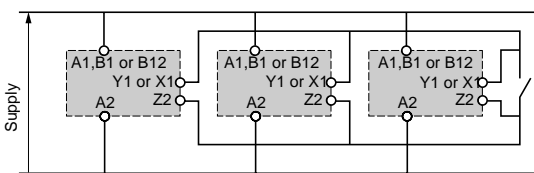

Connection of a Telemecanique 3-wire NPN or PNP sensor

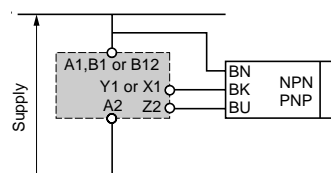

It is advisable to follow the recommended wiring schemes detailed above and on previous pages. However, the connections below are possible if the restrictions given are taken into account.

Connection of an external control contact without using terminal Z2 :

- possible on all RE7 relays with external control option except RE7 RA11BU,
- d.c. supply only.

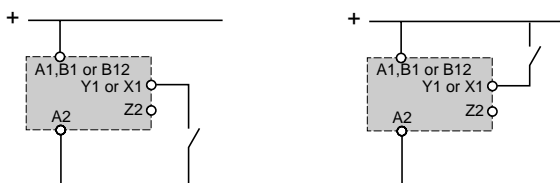

Connection of a Telemecanique 3-wire NPN or PNP sensor without using terminal Z2 :

- only possible on relay RE7●●●●BU,
- d.c. supply only.

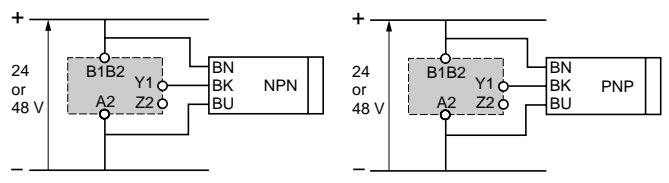

Zelio Time - timing relays

Industrial, single-function relays,
relay output, width 22.5 mm

Output 1 C/O contact
Multiple timing ranges

Function diagrams

Function A

Delay on energisation

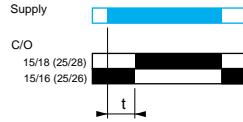

Function Wt

External control for start of time delay

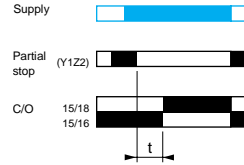

Function At

External control for partial stop of time delay (with memory)

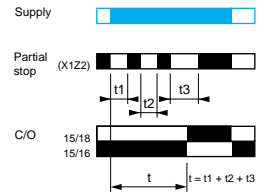

Function H

Pulse-on energisation
Start on energisation

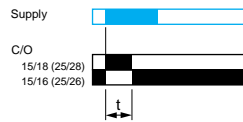

Function Hi

Start on opening of external control contact

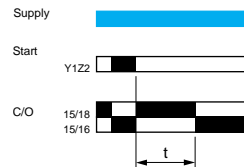

Function Ht

External control for partial stop of time delay (with memory)

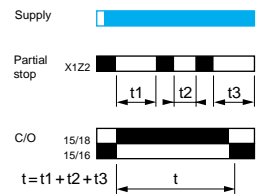

References



Functions	A	A, Wt, At	Ac	Ae, Af
Timing ranges	0.05 s...300 h 10 ranges	0.05 s...300 h 10 ranges	0.05 s...300 h 10 ranges	0.05 s...300 h 10 ranges
Voltages	≡ or ~ 24 V	●	●	●
	~ 110...240 V	●	●	●
	~ or ≡ 42...48 V	—	●	●
	≡ or ~ 24...240 V	—	—	—
References	RE7 TL11BU	RE7 TM11BU	RE7 MA11BU	RE7 MV11BU
Weight (kg)	0.150	0.150	0.150	0.150

Dimensions and connection schemes

Dimensions

Rail mounting

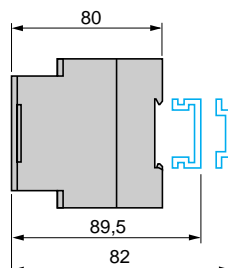

Screw fixing

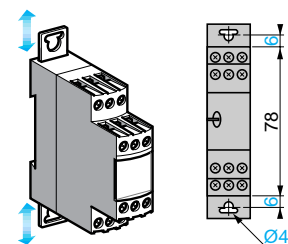

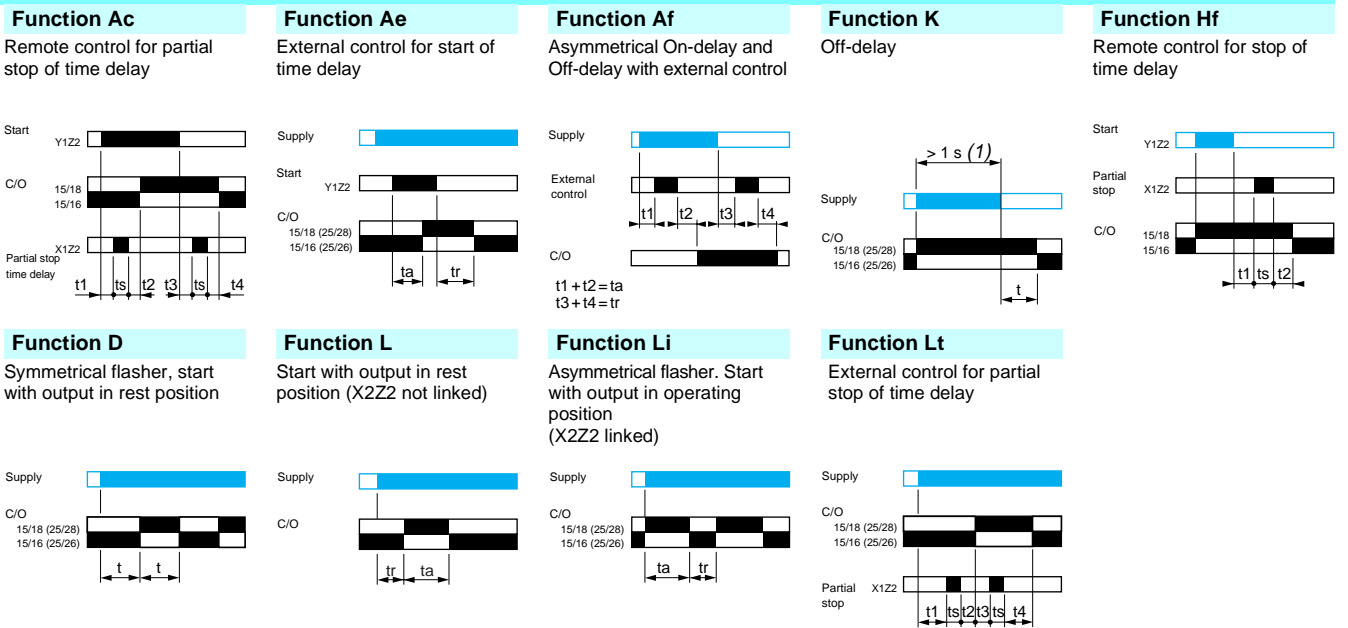

(1) If the device has been stored, de-energised, for more than a month, it must be energised for about 15 seconds in order to activate it. Subsequently, it only takes 1 second to start the time delay. Δ If this time is not complied with, the relay remains energised indefinitely.



K	Hf	H	Hi, Ht	D	L, Li, Lt
0.05 s...10 min	0.05 s...300 h	0.05 s...300 h	0.05 s...300 h	0.05 s...300 h	0.05 s...300 h
7 ranges	10 ranges	10 ranges	10 ranges	10 ranges	10 ranges
-	●	●	●	●	●
-	●	●	●	●	●
-	●	-	●	-	●
●	-	-	-	-	-
RE7 RB11MW	RE7 RA11BU RE7 RM11BU low level contact	RE7 PE11BU	RE7 PM11BU	RE7 CL11BU	RE7 CV11BU
0.150	0.150	0.150	0.150	0.150	0.150

Connections

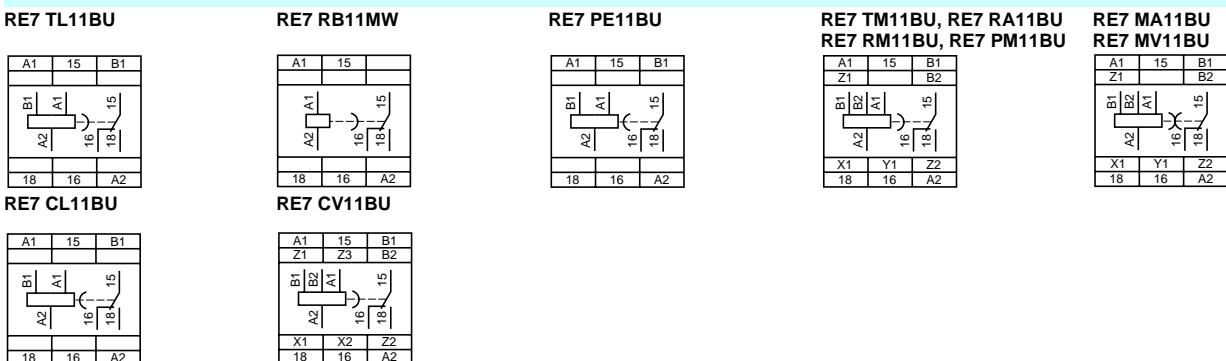

Characteristics :
pages 28450/2 and 28450/3

Dimensions :
page 28504/2

Schemes :
pages 28506/2 and 28506/3

Presentation



The RE8 range of relays is designed for simple and repetitive applications, providing basic functions.

Each relay comprises :
- a single timing range,
- a C/O output relay

These products have a transparent, hinged flap on their front face to avoid any accidental alteration of the settings. This flap can be directly sealed.

Environment

Conforming to standards			IEC 61812-1, EN 61812-1
Approvals			CSA, GL pending, UL
CE marking			Zelio Time timing relays conform to European regulations relating to CE marking
Ambient air temperature around the device	Storage	°C	- 40...+ 85
	Operation	°C	- 20...+ 60
Permissible relative humidity range	Conforming to IEC 60721-3-3		15...85 % Environmental class 3K3
Vibration resistance	Conforming to IEC 6068-2-6, 10 to 55 Hz		a = 0.35 ms
Shock resistance	Conforming to IEC 6068-2-27		15 gn - 11 ms
Degree of protection	Casing		IP 50
	Terminals		IP 20
Degree of pollution	Conforming to IEC 60664-1		3
Overvoltage category	Conforming to IEC 60664-1		III
Rated insulation voltage	Conforming to IEC	V	250
	Conforming to CSA	V	300
Test voltage for insulation tests	Dielectric test	kV	2.5
	Shock wave	kV	4.8
Voltage limits	Power supply circuit		0.9...1.1 Uc
Frequency limits	Power supply circuit	Hz	50/60 ± 5 %
Disconnection value	Power supply circuit		> 0.1 Uc
Mounting position without derating	In relation to normal vertical mounting plane		Any position
Connection maximum c.s.a.	Flexible cable without cable end	mm ²	2 x 2.5
	Flexible cable with cable end	mm ²	2 x 1.5
Tightening torque		N.m	0.6...1.1

Immunity to electromagnetic interference (EMC) (Application class 2 conforming to EN 61812-1)

Electrostatic discharge	Conforming to IEC 61000-2-6		Level 3 (6 kV contact, 8 kV air)
Electromagnetic fields	Conforming to IEC 61000-4-3		Level 3 (10 V/m)
Fast transients	Conforming to IEC 61000-4-4		Level 3 (2 kV)
Shock waves	Conforming to IEC 61000-4-5		Level 3 (2 kV)
Radiated and conducted emissions	CISPR11		Group 1 class A
	CISPR22		Class A

Consumption

Consumption	RE8-TA, RA, CL, PE, PU, PT RE8-YG, RB RE8-YA	VA	~	110 V	240 V	380 V	415 V	W	24 V				
			0.7						1.8	8.5	-	-	0.5
			0.9						2.5	13	-	-	0.5
			0.9						2.5	13	8	9	0.7

References :
pages 28507/2 to 28508/3

Dimensions:
pages 28507/2 and

28508/2
Schemes :

pages 28507/2 and 28507/
3

Timing characteristics

Setting accuracy	As % of the full-scale value		± 20 %
Repeat accuracy			< 1 %
Influence of voltage	In the voltage range, 0.9...1.1 Un		< 2.5 %
Influence of temperature			<0.2 %/°C
Immunity to microbreaks		ms	3
Minimum control pulse		ms	26 (except RE8-YG : 60)
Reset time		ms	50

Output circuit characteristics

Maximum switching voltage		V	≈ 250
Mechanical durability	In millions of operating cycles		20
Current limit I _{th}		A	8
Rated operational limits at 70 °C Conforming to IEC 60947-5-1/1991 and VDE 0660	AC-15	A	24 V 115 V 250 V 3 3 3
	DC-13	A	2 0.2 0.1
Minimum switching capacity			12 V/10 mA
Contact material			90/10 nickel silver

Remote control input characteristics

Signal delivered by control input Y1 ⚠ No galvanic insulation between this input and the supply	No-load voltage		Supply voltage
	Switching current	mA	< 10
	Maximum distance	m	50
	Compatibility		2-wire sensors with leakage current < 1 mA

a.c. load

Curve 1

Electrical durability of contacts on resistive load in millions of operating cycles

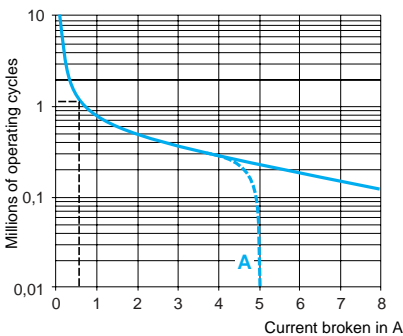

Curve 2

Reduction factor k for inductive loads (applies to values taken from the durability curve opposite)

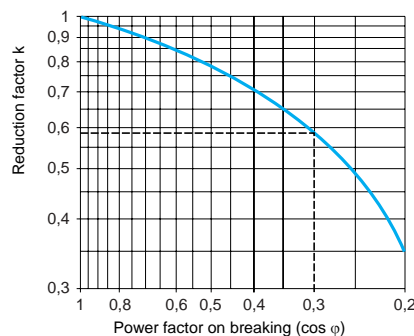

d.c. load

Load limit curve

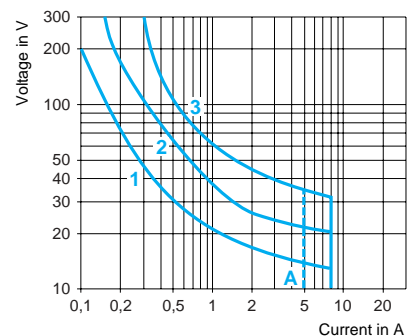

A RE8-RB●●BUTQ

Example :

An LC1-F185 contactor supplied with 115 V/50 Hz for a consumption of 55 VA or a current consumption equal to 0.1 A and $\cos \varphi = 0.3$

For 0.1 A, curve 1 indicates a durability of approximately 1.5 million operating cycles.

As the load is inductive, it is necessary to apply a reduction coefficient k to this number of cycles as indicated by curve 2.

For $\cos \varphi = 0.3$: $k = 0.6$

The electrical durability therefore becomes :

$1.5 \cdot 10^6$ operating cycles \times 0.6 = 900 000 operating cycles

A RE8-RB●●BUTQ

- 1 L/R = 20 ms
- 2 L/R with load protection diode
- 3 Resistive load

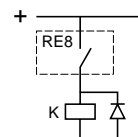

Zelio Time - timing relays

Industrial single-function relays, optimum relay output, width 22.5 mm

Output 1 C/O contact
Single timing range

Function diagrams

Function A

Start on energisation

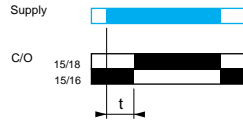

Function C

With control contact

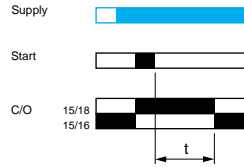

References (Sold in packs of 10)



Functions		A	C
Voltages	≡ or ~ 24 V	●	—
	~ 110...240 V	●	●
	~ 380...415 V	—	—
Timing ranges	0.05 s...0.5 s	—	—
	0.1 s...3 s	RE8 TA61BUTQ	—
	0.1 s...10 s	RE8 TA11BUTQ	RE8 RA11BTQ RE8 RA11FUTQ
	0.3 s...30 s	RE8 TA31BUTQ	RE8 RA31BTQ RE8 RA31FUTQ
	3 s...300 s	RE8 TA21BUTQ	RE8 RA21BTQ RE8 RA21FUTQ
	20 s...30 min	RE8 TA41BUTQ	— RE8 RA41FUTQ
Weight (kg)		0.110	0.110 0.110

Dimensions

Dimensions

Rail mounting

Screw fixing

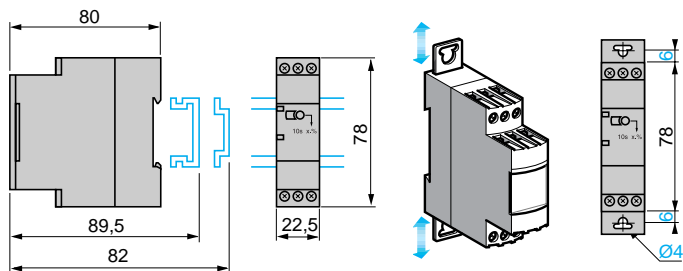

Function K

Off-delay

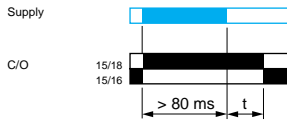

Function D

Symmetrical

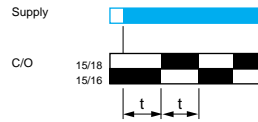

K

•
•
-
RE8 RB51BUTQ
-
RE8 RB11BUTQ
RE8 RB31BUTQ
-
-
0.110

D

•
•
-
RE8 CL11BUTQ
-
-
-
0.110

Schemes

Connection schemes

RE8 TA, CL

RE8 RA

RE8 RB

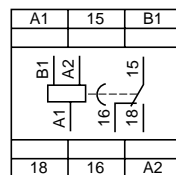
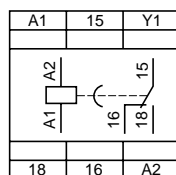
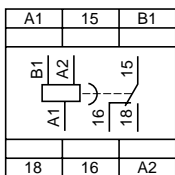

Recommended application schemes

RE8 TA, CL

RE8 RA

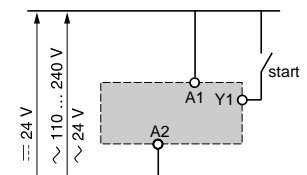
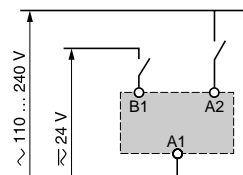

Control of several relays with a single external control contact

RE8 RA, RE8 PD

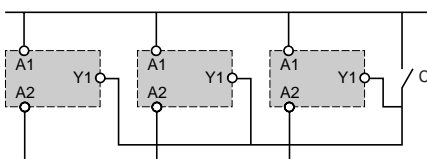

The external control contact C may be an electronic control device, for example a 2-wire sensor. In this case A1-A2 = \approx 24 V and the control device can only control up to a maximum of 4 relays.

Connection of a \approx 2-wire sensor

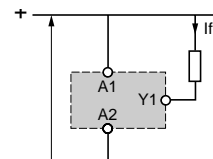

Leakage current (open state) $I_f < 1$ mA.

Function He

Pulse-on energisation, start on de-energisation

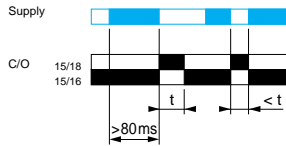

Function Qc

Timing relay for star-delta starters

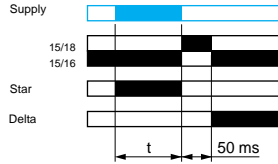

Function Qe

Timing relay for star-delta starters

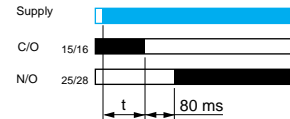

He	Qc	Qe
●	●	-
●	●	-
-	-	●
RE8 PT01BUTQ	RE8 YG11BUTQ	RE8 YA32BTQ
-	RE8 YG31BUTQ	RE8 YA32FUTQ
-	RE8 YG21BUTQ	RE8 YA32QTQ
-	-	-
0.110	0.110	0.110

Recommended application schemes

Pulse-on energisation relays

RE8 PE, RE8 PT

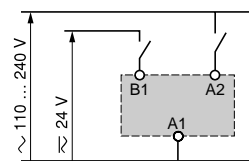

RE8 PD

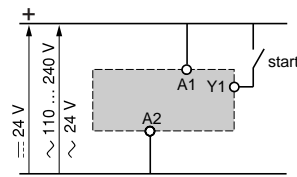

Timing relays for star-delta starters

RE8 YG, RE8 YA

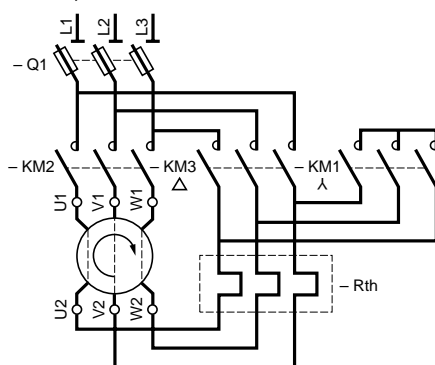

RE8 YG

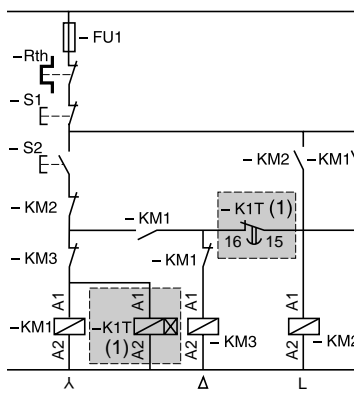

(1) K1T : RE8-YG●1●●TQ

RE8 YA

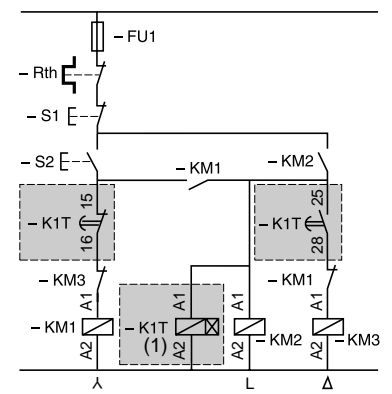

(1) K1T : RE8-YA32●●TQ

Note : Correct operation of the star-delta starter associated with the RE8 YG is only possible if the wiring scheme is strictly complied with.

Zelio Time - timing relays

Universal plug-in relays, 8-pin,
relay output, width 35 mm

Timing characteristics

Repeat accuracy (with constant parameters)	Conforming to IEC 1812-1		± 0.5 %
Drift	Temperature		± 0.05 % / °C
	Voltage		± 0.2 % / V
Full scale setting accuracy	Conforming to IEC 1812-1		± 10 % at 25 °C
Minimum duration of control impulse	Typical	ms	30
	Typical under load	ms	100
Maximum reset time by de-energisation	Typical	ms	100
Immunity time to microbreaks	Typical	ms	> 10



Supply characteristics

Multivoltage supply			Depending on version, see pages 28511/4 and 28511/5	
Frequency		Hz	50/60	
Operating range			85...110 Un % (85...120 Un for \sim/\equiv 12 V)	
On-load factor			100 %	
Maximum power consumption	Depending on model	\equiv 24 V	W	0.6
		\equiv 240 V	W	1.5
		\sim 240 V	VA	32

Output characteristics

Output type			Relay, 1 or 2 C/O contacts, AgNi (cadmium -free)
Breaking capacity			\sim 2000 VA, \equiv 80 W
Maximum breaking current		A	\sim 8, \equiv 8
Minimum breaking current		mA	10/ \equiv 5 V
Maximum switching voltage		V	\sim/\equiv 250
Electrical life			10 ⁹ operations 8 A 250 V resistive
Mechanical life			5 x 10 ⁶ operations
Dielectric strength	Conforming to IEC 1812-1	kV	2.5/1min/1 mA/50 Hz
Impulse voltage	Conforming to IEC 664-1, IEC 1812-1	kV	5, wave 1.2/50 μ s

Display characteristics

State indication by 1 LED	Green		<p>Operating status indication</p> <p> Pulsing : relay energised, no timing in progress (except Di-D and Li-L)</p> <p> Flashing : timing in progress</p> <p> On steady : relay energised, no timing in progress</p>
---------------------------	-------	--	--

Input characteristics

Input type		V	Volt-free contact (no potential) Control possible by 3-wire sensor with PNP output, maximum residual voltage : 0.4 V whatever the supply voltage of the timer
------------	--	---	--

Zelio Time - timing relays

Universal plug-in relays, 8-pin,
relay output, width 35 mm

General characteristics

Conforming to standards			IEC 1812-1, EN 50081-1/2, EN 50082-1/2, LV directives (73/23/EEC + 93/68/EEC (CE marking) + EMC (89/336/EEC + IEC 669-2-3)	
Approvals			c UR us, CSA, GL	
Temperature limits	Operation	°C	- 20...+ 60	
	Storage	°C	- 30...+ 60	
Creepage distance and clearance	Conforming to IEC 60664-1	kV	4 kV/3	
Degree of protection conforming to IEC 529	Terminal block		IP 20	
	Enclosure		IP 40	
	Front panel		IP 50	
Vibration resistance			f = 10...55 Hz A = 0.35 mm	
Relative humidity without condensation	Conforming to IEC 68-2-3		93 %	
Electromagnetic compatibility	Immunity to electrostatic discharge, conforming to IEC 1000-42		Level III (Air 8 kV/Contact 6 kV)	
	Immunity to electromagnetic fields, conforming to ENV 50140/204 (IEC 1000-4-3)		Level III 10 V/m : (80 MHz...1 GHz)	
	Immunity to fast transients in bursts conforming to IEC 1000-4-4		Level III (direct 2 kV / capacitive connecting clip 1 kV)	
	Immunity to surges on the power supply, conforming to IEC 1000-4-5		Level III (common mode 2 kV / differential mode 1 kV)	
	Immunity to radio frequency interference in common mode conforming to ENV 50141 (IEC 1000-4-6)		Level III (10 V rms : 0.15...80 MHz)	
	Immunity to voltage dips and breaks conforming to IEC 1000-4-11			30 % / 10 ms
				60 % / 100 ms >
			95 % / 5 s	
Radiated and mains conducted disturbance conforming to EN 55022 (EN 55011 Group 1)			Class B	
Fixing	Plug-in socket		8-pin	
Enclosure material			Self-extinguishing	

Zelio Time - timing relays

Universal plug-in relays, 8-pin
relay output, width 35 mm

Relay output, 1 or 2 C/O contacts

- Multifunction of single function
- Multi-range (7 switchable ranges)
- Multivoltage
- Output 1 or 2 relay : 8 A - 250 V (10 A UL)
- Plug-in
- State indication by 1 LED
- Option of supplying a load in parallel
- 3-wire sensor control option

Function diagrams

Function A

Delay on energisation
1 contact

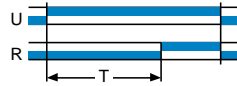

2 timed contacts

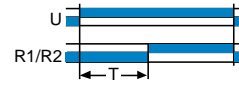

Function C

Off-delay
1 timed contact

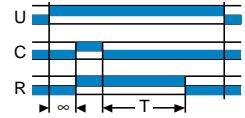

Function Di

Flashing relay
Pulse start

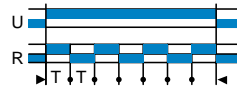

Function B

Timing on impulse, one shot

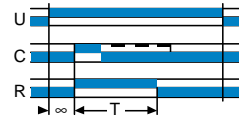

Function Ht

Delay on energisation with memory

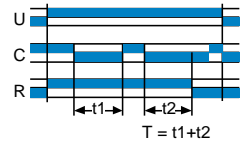

References



Connection	Plug-in sub-base	●	●	●
Functions		Multifunction A - At - B - C - H - Ht - Di - D Ac - Bw	Single function A	Single function C
Timing ranges	7 ranges	1 s - 10 s - 1 min - 10 min - 1 h - 10 h - 100 h		
Relay output		1 timed contact	2 timed contacts	1 timed contact
Rated current		8 A	8 A	8 A
Voltages	$\overline{\sim}$ 24 V / \sim 24...240 V $\sim/\overline{\sim}$ 12 V $\sim/\overline{\sim}$ 12...240 V	RE 88 867 105	RE 88 867 215	RE 88 867 135
Weight (kg)		0.080	0.080	0.080
Socket (1)	8-pin	RUZ 1D	RUZ 1D	RUZ 1D
	Weight (kg)	0.067	0.067	0.067

(1) These products are sold in packs of 10

Dimensions and connection schemes

Dimensions

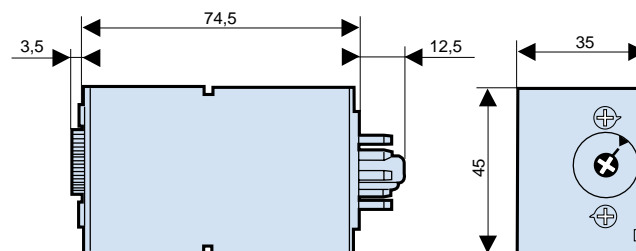

Function L

Asymmetrical recycler
Start after pause

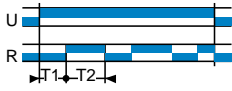

Function D

Flashing relay
Start after pause

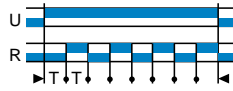

Function At

Timing on energisation
with memory

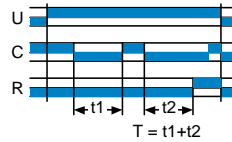

Function H

Timing on energisation

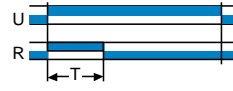

Function Li

Asymmetrical recycler
Pulse start

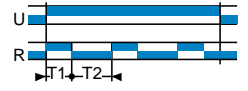

Function Ac

Timing after closing/opening
of control contact



Function Bw

Pulse output (adjustable)

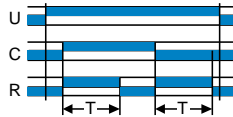

Dual function

Li - L

1 s - 10 s - 1 min - 10 min - 1 h - 10 h - 100 h

1 timed contact

8 A

RE 88 867 155

-

-

0.080

RUZ 1D

0.067

Multifunction

A - At - B - C - H - Ht - Di - D - Ac - Bw

1 timed contact

8 A

RE 88 867 100

-

0.080

RUZ 1D

0.067

Multifunction

A - At - B - C - H - Ht - Di - D - Ac - Bw

1 timed contact

8 A

RE 88 867 103

-

0.080

RUZ 1D

0.067

Connection schemes

Timing relays with 1 relay output
All functions except L and Li

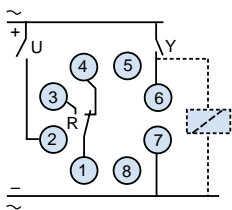

Functions L and Li

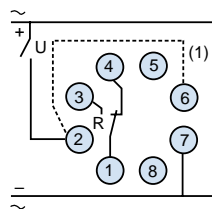

(1) Link between pins 2 and 6 for function L only.

Timing relays with 2 relay outputs Function A

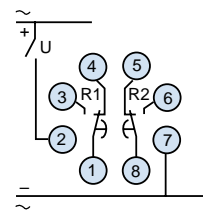

Timing characteristics

Repeat accuracy (with constant parameters)	Conforming to IEC 1812-1		± 0.5 %
Drift	Temperature		± 0.05 % / °C
	Voltage		± 0.2 % / V
Full scale setting accuracy	Conforming to IEC 1812-1		± 10 % at 25 °C
Minimum duration of control impulse	Typical	ms	30
	Typical under load	ms	100
Maximum reset time by de-energisation	Typical	ms	100
Immunity time to microbreaks	Typical	ms	> 10



Supply characteristics

Multivoltage supply			Depending on version, see pages 28512/4 and 28512/5	
Frequency		Hz	50/60	
Operating range			85...110 % Un (85...120 Un for \sim/\equiv 12 V)	
On-load factor			100 %	
Maximum power consumption	Depending on model	\equiv 24 V	W	0.6
		\equiv 240 V	W	1.5
		\sim 240 V	VA	32

Output characteristics

Output type			Relay, C/O contacts, AgNi (cadmium free)
Breaking capacity			\sim 2000 VA, \equiv 80 W
Maximum breaking current		A	\sim 8, \equiv 8
Minimum breaking current		mA	10 \neq 5 V
Maximum switching voltage		V	\sim/\equiv 250
Electrical life			10 ⁹ operations 8 A 250 V resistive
Mechanical life			5 x 10 ⁶ operations
Dielectric strength	Conforming to IEC 1812-1	kV	2.5/1min/1 mA/50 Hz
Impulse voltage	Conforming to IEC 664-1, IEC 1812-1	kV	5, wave 1.2/50 μ s

Display characteristics

State indication by 1 LED	Green		Operating status indication  Pulsing : relay energised, no timing in progress (except Di-D and Li-L)  Flashing : timing in progress  On steady : relay energised, no timing in progress
---------------------------	-------	--	---

Input characteristics

Input type		V	Volt-free contact (no potential) Control possible by 3-wire sensor with PNP output, maximum residual voltage : 0.4 V whatever the supply voltage of the timer
------------	--	---	--

Zelio Time - timing relays

Universal plug-in relays, 11-pin,
relay output, width 35 mm

General characteristics

Conforming to standards			IEC 1812-1, EN 50081-1/2, EN 50082-1/2, LV directives (73/23/EEC + 93/68/EEC (CE marking) + EMC (89/336/EEC + IEC 669-2-3)	
Approvals			c UR us, CSA, GL	
Temperature limits	Operation	°C	- 20...+ 60	
	Storage	°C	- 30...+ 60	
Creepage distance and clearance	Conforming to IEC 60664-1	kV	4 kV/3	
Degree of protection conforming to IEC 529	Terminal block		IP 20	
	Enclosure		IP 40	
	Front panel		IP 50	
Vibration resistance	Conforming to IEC 68-2-6		f = 10...55 Hz A = 0.35 mm	
Relative humidity without condensation	Conforming to IEC 68-2-3		93 %	
Electromagnetic compatibility	Immunity to electrostatic discharge, conforming to IEC 1000-42		Level III (Air 8 kV/Contact 6 kV)	
	Immunity to electromagnetic fields, conforming to ENV 50140/204 (IEC 1000-4-3)		Level III 10 V/m : (80 MHz...1 GHz)	
	Immunity to fast transients in bursts, conforming to IEC 1000-4-4		Level III (direct 2 kV / capacitive connecting clip 1 kV)	
	Immunity to surges on the power supply, conforming to IEC 1000-4-5		Level III (common mode 2 kV / differential mode 1 kV)	
	Immunity to radio frequency interference in common mode conforming to ENV 50141 (IEC 1000-4-6)		Level III (10 V rms : 0.15...80 MHz)	
	Immunity to voltage dips and breaks, conforming to IEC 1000-4-11			30 % / 10 ms
				60 % / 100 ms >
			95 % / 5 s	
Radiated and mains conducted disturbance, conforming to EN 55022 (EN 55011 Group 1)			Class B	
Fixing	Plug-in socket		11-pin	
Enclosure material			Self-extinguishing	

Zelio Time - timing relays

Universal plug-in relays, 11-pin,
relay output, width 35 mm

Relay output, 2 C/O contacts

- Multifunction or single function
- Multi-range (7 switchable ranges)
- Multivoltage
- Output 2 relay : 8 A - 250 V (10 A UL)
- Plug-in
- State indication by 1 LED
- Option of supplying a load in parallel
- 3-wire sensor control possible

Function diagrams

Function A

Delay on energisation
2 timed contacts or
2 timed contacts, 1 of which
convertible to instantaneous

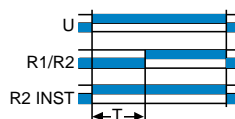

Function C

Off-delay
2 timed contacts or
2 timed contacts, 1 of which
convertible to instantaneous

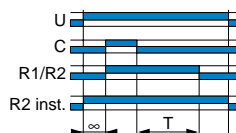

Function Ac

Timing after closing/opening
of control contact
2 timed contacts or
2 timed contacts, 1 of which
convertible to instantaneous

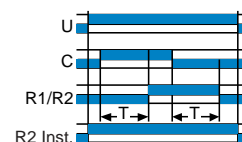

Function B

Timing on impulse, one shot
2 timed contacts or
2 timed contacts, 1 of which
convertible to instantaneous

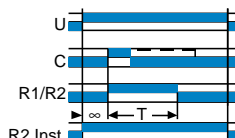

Function Ht

Delay on energisation with
memory
2 timed contacts or
2 timed contacts, 1 of which
convertible to instantaneous

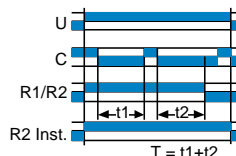

Function Di

Flashing relay
Pulse start
2 timed contacts or
2 timed contacts, 1 of which
convertible to instantaneous

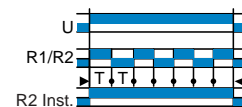

References



Connection	Plug-in sub-base	●	●	●
Functions		Multifunction A - At - B - C - H - Ht - Di - D Ac - Bw	Dual function A - At	Single function C
Timing ranges	7 ranges	1 s - 10 s - 1 min - 10 min - 1 h - 10 h - 100 h		
Relay output		2 timed contacts, 1 convertible to instantaneous	2 timed contacts	2 timed contacts
Rated current		8 A	8 A	8 A
Voltages	$\overline{\text{---}}$ 24 V / \sim 24...240 V	RE 88 867 305	RE 88 867 415	RE 88 867 435
	$\sim/\overline{\text{---}}$ 12 V	-	-	-
	$\sim/\overline{\text{---}}$ 12...240 V	-	-	-
Weight (kg)		0.080	0.080	0.080
Socket (1)	11-pin,	RUZ 1A	RUZ 1A	RUZ 1A
	Weight (kg)	0.067	0.067	0.067

(1) These products are sold in packs of 10

Dimensions and connection schemes

Dimensions

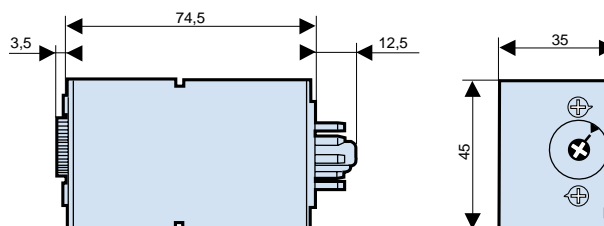

Function Bw

Pulse output (adjustable)
2 timed contacts or
2 timed contacts, 1 of which
convertible to instantaneous

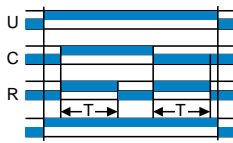

Function At

Function H

Function D

Function L

Timing on energisation with
memory
2 timed contacts or
2 timed contacts, 1 of which
convertible to instantaneous

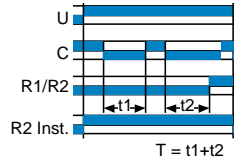

Timing on energisation
2 timed contacts or
2 timed contacts, 1 of which
convertible to instantaneous

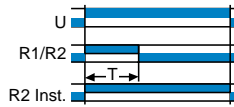

Flashing relay
Start after pause
2 timed contacts or
2 timed contacts, 1 of which
convertible to instantaneous

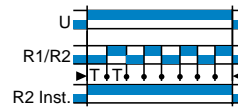

Asymmetrical recycler
Start after pause
2 timed contacts

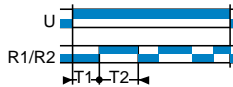

Function Li

Asymmetrical recycler
Pulse start
2 timed contacts

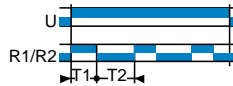

Dual function	Multifunction	Multifunction
Li - L	A - At - B - C - H - Ht - Di - D - Ac - Bw	A - At - B - C - H - Ht - Di - D - Ac - Bw
1 s - 10 s - 1 min - 10 min - 1 h - 10 h - 100 h		
2 timed	2 timed contacts, 1 convertible to instantaneous	2 timed contacts, 1 convertible to instantaneous
8 A	8 A	8 A
RE 88 867 455	-	-
-	RE 88 867 300	-
-	-	RE 88 867 303
0.080	0.080	0.080
RUZ 1A	RUZ 1A	RUZ 1A
0.067	0.067	0.067

Connection schemes

All functions except L and Li

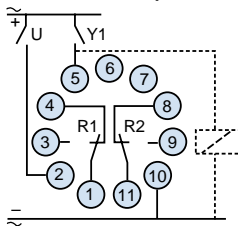

Functions L and Li

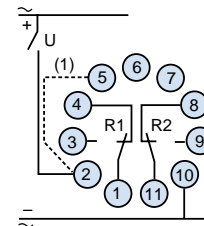

(1) Link between pins 2 and 5 for function L only.

Timing characteristics

Repeat accuracy (with constant parameters)			± 0.5 %
Full scale setting accuracy	Conforming to IEC/EN 61812-1		10 % at 25 °C
Temperature drift			0.05 %/ °C
Maximum reset time by de-energisation	During time delay period	ms	50
	After time delay period	ms	250
Immunity to microbreaks		ms	≤ 5
Voltage drift			± 0.2 % / V

Output characteristics

Output type	Relay		4 cadmium-free C/O contacts
Rated current		A	~ 3
Rated insulation voltage		V	~ 250
Maximum breaking capacity (resistive)		A	4 x 5
Maximum permissible current		A	10 < 0.01 s
Minimum breaking current		mA	100
Electrical life at I max ~ 250 V resistive			10 ⁵ operating cycles
Mechanical life			10 ⁷ operations
Dielectric strength	To IEC/EN 61812-1 and 60601-1		2 kV at 1 mA for 1 min at 50 Hz

General characteristics

State indication by LED	Output in operation		Red LED
	Power on		Green LED
Permissible voltage variation	≡ 12 V		± 10 %
	≡ 24 V		± 10 %
	~ 24 V		± 15 %
	~ 120 V		± 15 %
	~ 230 V		± 15 %
Frequency		Hz	50/60 ± 1
Maximum power consumption	≡ 12 V	W	1.5
	≡ 24 V	W	1.2
	~ 24 V	VA	1.6
	~ 120 V	VA	2.6
	~ 230 V	VA	3
Temperature limits	Operation	°C	- 20...+ 60
	Storage	°C	- 40...+ 70
Insulation voltage	To standard VDE 0010 IEC 255 Group C	V	~/≡ 250
Degree of protection	Conforming to IEC 60529		IP 50
Conforming to standards			IEC/EN 61812-1, 60601-1, 60601-2, EN 50081-2, 61000-6-2, LV (73/23/EEC + 93/68/EEC) + EMC (89/336/EEC) directives
Overvoltage protection		joules	2
Approvals			UL-cUL (pending)
Printed circuit board base			● ●
DIN screw terminal base			● ●
Vibration resistance	Conforming to IEC 60068-2-6, 10 to 55 Hz		a = 0.35 mm
Relative humidity	Conforming to IEC 60068-2-3 without condensation		95 % max

Immunity to electromagnetic interference (EMC) (application class 2 conforming to EN 61812-1/A11)

Electrostatic discharge	Conforming to IEC/EN 61000-4-2		Level 3 (Air 8 kV contact, 6 kV)
Electromagnetic fields	Conforming to IEC/EN 61000-4-3		Level 3 (10 V/m)
Fast transients	Conforming to IEC/EN 61000-4-4		Level 3 (2 kV)
Shock waves	Conforming to IEC/EN 61000-4-5		Level 3 (2 kV)
Radio frequencies in common mode	Conforming to IEC/EN 61000-4-6		Level 3 (10 V rms from 0.15 MHz to 80 MHz)
Voltage dips and breaks	Conforming to IEC/EN 61000-4-11		30 %/10 ms, 60 %/100 ms and 1 s, > 95 %/5 s
Radiated and conducted emissions	Conforming to EN 55022 (EN 55011 group 1)		Class B
Creepage distance and clearance	Conforming to IEC 60664-1	kV	4 kV/3

Internal schemes

Relay with 4 C/O contacts

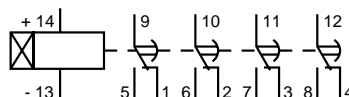

Zelio Time - timing relays

Miniature plug-in relays,
relay output

Relay output

- Miniature and plug-in (21 x 27 mm)
- Function A : on-delay
- 7 timing ranges : 0.1 s to 100 h
- Excellent immunity to interference
- Relay outputs with 4 C/O contacts, 5 A ~ 250 V
- Power on and relay energised indication by 2 LEDs

Function diagrams

Function A

4 relay

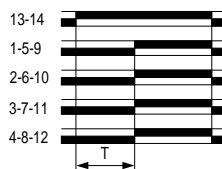

References



Functions		Single function
		A
Timing ranges	7 switchable ranges	0.1 s...1 s - 1 s...10 s - 0.1 min...1 min - 1 min...10 min - 0.1 h...1 h - 1 h...10 h - 10 h...100 h
Relay output		4 timed C/O contacts
Rated current		~ 5 A
Voltages	~ 12 V	RE 88 896 201
	~ 24 V (1)	RE 88 896 202
	~ 24 V 50/60 Hz (1)	RE 88 896 203
	~ 120 V 50/60 Hz	RE 88 896 206
	~ 230 V 50/60 Hz	RE 88 896 207
Weight (kg)		0.050
Socket (2)		RXZ E15114M
	Weight (kg)	0.055

(1) For ~ 48 V supply, additional resistor 560 Ω 2 W / ~ 24 V,
For c 48 V supply, additional resistor 390 Ω 4 W / c 24 V.

(2) These products are sold in lots of 10.

Dimensions and terminal referencing

Dimensions

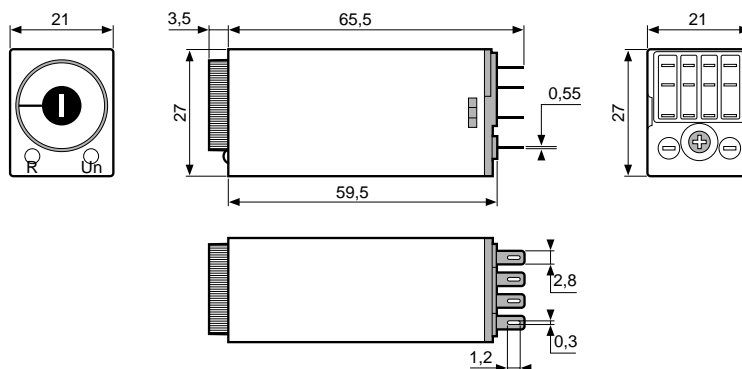

Terminal referencing

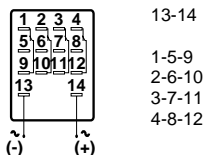

Timing characteristics

Relay type		RE 88 886 00●	RE 88 886 104	RE 88 886 506
Repeat accuracy (with constant parameters)		± 0.5 %		± 0.2 %
Temperature drift conforming to VDE 0435	0...40 °C	± 3 %		± 1 %
	- 20...+ 60 °C	± 5 %		± 1.5 %
Full scale setting accuracy		± 5 %		± 10 %
Minimum duration of control impulse		s	0.02	–
Maximum reset time	By de-energisation	ms	100	–
	After time delay period	ms	–	50
	During time delay period	ms	–	100
Immunity to microbreaks		s	0.02	0.02

Output characteristics

Rated current		A	~ 8, ≡ 1	~ 8, ≡ 1
Rated insulation voltage		V	~ / ≡ 250	~ / ≡ 250
Breaking capacity			1100 VA/30 W	2000 VA/30 W
Maximum permissible current		A	15 < 0.01 s	15 < 0.01 s
Minimum current		mA	~ / ≡ 50	~ / ≡ 50
Electrical life at I max - ~ 250 V resistive			10 ⁵ operating cycles	2 x 10 ⁵ operating cycles
Permissible number of operations at I max - ~ 250 V resistive			600 operations	600 operations
Mechanical life			10 ⁷ operations	2 x 10 ⁷ operations

General characteristics

State indication by LED	"UP" relay energised		Green LED	Green LED
	"ON" power on		Red LED	Red LED
Permissible voltage variation	~ / ≡ 24 V		± 15 %	–
	~ 110...127 V		- 15...+ 10 %	–
	~ 220...240 V		- 15...+ 10 %	- 15...+ 10 %
Maximum power consumption	≡ 24 V	W	1.5	–
	~ 110...127 V	VA	5	–
	~ 220...240 V	VA	10	20
Temperature limits	Operation	°C	- 20...+ 60	- 20...+ 60
	Storage	°C	- 25...+ 70	- 25...+ 70
Insulation voltage	Conforming to standard VDE 0110 - IEC 255 Group C	V	~ / ≡ 250	~ / ≡ 250
Dielectric strength	Conforming to standard IEC 255 or VDE 0435	V	–	Un ≤ 60 V : 500 Un ≤ 60 V : 2000
Protection class	Conforming to NFC 20010 - IEC 529 - DIN 40050		IP 40	IP 50
Conforming to standards			IEC 255 - VDE 0435 - 2021	IEC 255 - VDE 0435 - 2021
Approvals			c UR us, CSA	c UR us, CSA
Fixing	Panel-mounted		By clip	By clip
	Base-mounted		On socket	On socket

Internal schemes

Relay RE 88 886 00●

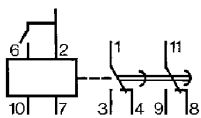

Relay RE 88 886 104

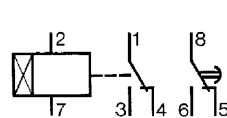

Relay RE 88 886 504

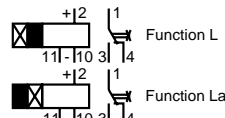

Terminal referencing

Relay RE 88 886 00●

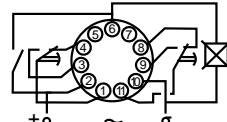

Relay RE 88 886 104

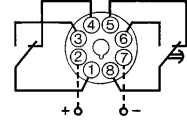

Relay RE 88 886 506

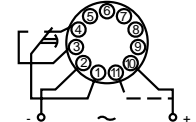

2-10 Supply	●	–	●
Bridge (7-10) for 24 V supply	●	–	–
Bridge (10-11) for 24 V supply	–	–	●
Control contact (6-2)	●	–	–
1-3-4 Timed relay output	●	–	●
11-8-9 Timed relay output	●	–	–
2-7 Supply	–	●	–
1-3-4 Instantaneous relay output	–	●	–
8-5-6 Timed relay output	–	●	–

Relay output

- Multifunction or single function
- Multirange
- Multivoltage or single voltage
- 1 or 2 C/O contacts
- State indication by 2 LEDs
- Connection by 8-pin or 11-pin base fitting
- Enclosure 48 x 48 mm

Function diagrams

Function A

RE 88 886 00●
Delay on energisation

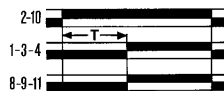

RE 88 886 104



Function B

Timing on impulse, one shot

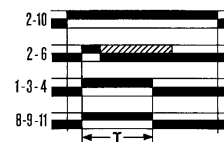

Function C

Off-delay

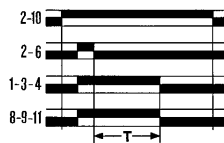

Function H

Timing on energisation

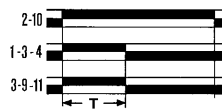

Function At

Timing on energisation with memory

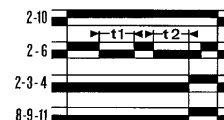

Function Ht

Delay on energisation with memory

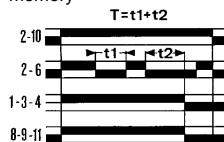

Function L

Asymmetrical recycler

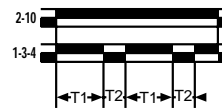

Function La

Asymmetrical recycler



References



Functions	Multifunction	Single function	Multifunction
	A, B, C, H, At, Ht	A	L, La
Timing ranges	8 switchable ranges 6 switchable ranges	0.1 s...1 s, 1 s...10 s, 6 s...60 s, 0.4... 4 min, 1 min...10 min, 6 min...60 min, 1 h...10 h, 6 h...60 h	00.1 s...1 s, 1 s...10 s, 0.1 min...1 min, 1 min...10 min, 0.1 h...1 h, 1 h...10 h
Relay output	2 timed C/O contacts	1 timed C/O contact 1 instantaneous C/O contact	1 timed C/O contact
Rated current	~ 5 A, --- 1 A V	~ 5 A, --- 1 A V	~ 8 A
Voltages	~ /--- 24 V and 100...127 V 50/60 Hz RE 88 886 005 ~ /--- 24 V and 220...240 V 50/60 Hz RE 88 886 006 ~ 220...240 V 50/60 Hz	— — RE 88 886 104	— — RE 88 886 506
Weight (kg)	0.110	0.110	0.110
Sockets (1)	8-pin 11-pin Weight (kg)	— RUZ 1A 0.067	— RUZ 1A 0.067

(1) These products are sold in packs of 10

Dimensions

Relays RE 88 886 00● and RE 88 886 104

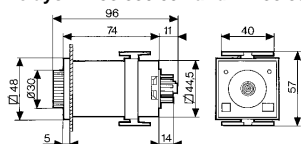

Relay RE 88 886 506

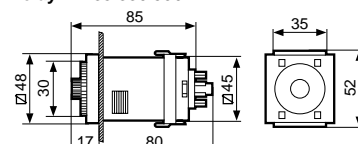

Panel cut-out

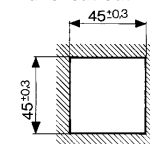

Timing characteristics

Repeat accuracy (with constant parameters)		± 0.2 %
Temperature drift	0...+ 40°C	± 1.5 %
conforming to VDE 0435	- 20...+ 60 °C	± 1.5 %
Full scale setting accuracy		± 10 %
Minimum duration of control impulse for relays RE 88 875 40●	ms	20
Max. reset time by de-energisation	During time delay period	ms 100
	After time delay period	ms 50
Immunity to microbreaks	s	0.02

Output characteristics

Rated current	A	~ 8, ≡ 8
Rated insulation voltage	V	~ / ≡ 250
Breaking capacity		2000 VA/80 W
Maximum permissible current	A	15 < 0.01s
Minimum current	mA	50
Electrical life at I max - ~ 250 V resistive		2 x 10 ⁵ operating cycles
Mechanical life		2 x 10 ⁷ operating cycles

Operating characteristics

State indication by LED	"UP" : output in operation		Red LED
	"ON" : power on		Green LED
Permissible voltage variation	≡ or ~ 24 V		± 15 %
	≡ or ~ 48 V		± 15 %
	~ 110 V		± 15 %
	~ 220...240 V		- 15...+ 10 %
Maximum power consumption	≡ 24 V	W	0.6
	~ 24 V	VA	1
	≡ 48 V	W	1.2
	~ 48 V	VA	1.2
	~ 110 V	VA	3.5
	~ 220 V	VA	7
Temperature limits	Operation	°C	- 20...+ 60
	Storage	°C	- 25...+ 70
Insulation voltage	Conforming to standard VDE 0110 - IEC255 Group C	V	~ / ≡ 250
Degree of protection	Conforming to NFC 20010 - IEC 529 - DIN 40050		IP 50
Conforming to standards			IEC 255 - VDE 0435 - 2021
Approvals			c UR us, CSA
Fixing	Panel-mounted		By clip
	Base-mounted		On socket
Material	Enclosure		Self-extinguishing ABS, UL 94 V0

Internal schemes

Relay RE 88 875 40●

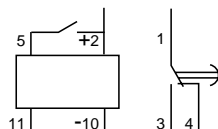

Relay RE 88 875 008

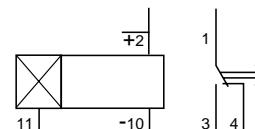

Zelio Time - timing relays

Panel-mounted electronic relays
with analogue setting

Relay output

- Multifunction or single function
- Multirange
- Multivoltage
- 1 C/O contact
- State indication by 2 LEDs
- Connection by 11-pin base fitting
- Enclosure 48 x 48 mm

Function diagrams

Function A

Delay on energisation

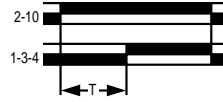

Function B

Timing on impulse, one shot

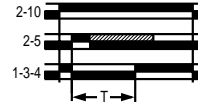

Function C

Off-delay



Function H

Timing on energisation

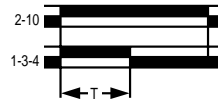

References



Functions		Multifunction	Multifunction
		A, B, C, H	A
Timing ranges	6 ranges	0.1 s...1 s - 1 s...10 s - 0,1 min...1 min - 1 min...10 min - 0.1 h...1 h - 1 h...10 h	
Relay output		1 timed C/O contact	1 timed C/O contact
Rated current		8 A	8 A
Voltages	\sim/\dots 24 V, \sim/\dots 48 V 50/60 Hz	RE 88 875 403	-
	\sim/\dots 24 V, \sim 110 V 50/60 Hz	RE 88 875 406	-
	\sim/\dots 24 V, \sim 220...240 V 50/60 Hz	RE 88 875 408	RE 88 875 008
Weight (kg)		0.100	0.100
Socket (1)	11-pin	RUZ 1A	RUZ 1A
	Weight (kg)	0.067	0.067

(1) These products are sold in packs of 10

Terminal referencing

Relay RE 88 875 40●

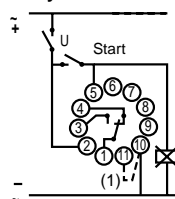

Relay RE 88 875 008

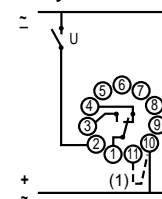

(1) Link 10-11 for \sim or \dots 24 V.

2-10 Supply	●	●
Link 10-11 for 24 V \sim or \dots supply	●	●
2-5 Control contact	●	-
1-3-4 Timed output contact	●	●

Dimensions

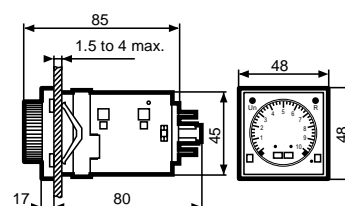

Panel cut-out

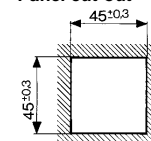

Display characteristics

Number of digits		4
Digit height	mm	8

Timing characteristics

Repeat accuracy (including temperature drift)		$\pm 0.005\% \pm 20\text{ ms}$ ($\pm 0.005\% \pm 50\text{ ms}$, if timing starts with ON)
Full scale setting accuracy		$\pm 0.05\% \pm 20\text{ ms}$
Reset time	By de-energisation	s ≤ 0.05
	By control contact	s ≤ 0.05
	By manual reset	s ≤ 0.05

Input characteristics

Control and reset input by contact	Solid state PNP Level 0	V	0...1
	Level 1	V	4...30
Impedance		K Ω	10, $\pm 10\%$
Minimum duration of control impulse		ms	50

Output characteristics

Rated current	A	$\sim 5, \text{---} 1$
Rated insulation voltage	V	$\sim/\text{---} 250$
Maximum breaking capacity (on a resistive load)		$\sim 1350\text{ VA} / \text{---} 30\text{ W}$
Electrical life at I max $\sim 250\text{ V}$ resistive		100 000 operating cycles
Mechanical life		20 million operating cycles

General characteristics			
Functions and EEPROM configuration memory		years	10
Permissible voltage variation			+ 10 ...- 15 %
Immunity to microbreaks		ms	≤ 3
Maximum power consumption	≡ 12 V	W	0.5
	≡ 24 V	W	1
	~ 24 V	VA	1.3
	~ 48 V	VA	4
	~ 115 V	VA	8
	~ 230 V	VA	17
	Temperature limits	Operation	°C
Storage		°C	- 25...+ 70
Front panel protection class			Conforming to NFC 20010 - IEC 529 - DIN 40050
Insulation voltage	Conforming to standard VDE 0110 and IEC 225 Group C	V	~ / ≡ 250
Dielectric strength	Conforming to IEC 255-5	kV	3
Test on power supply	Conforming to IEC 801-4 level 3	kV	2
Test on input signal	Conforming to IEC 801-4 level 3	kV	1
Damped oscillatory wave	Conforming to IEC 255-4	kV	3
Impulse voltage	Conforming to IEC 255-5	kV	5
Electrostatic discharge on front panel		kV	15
Front panel degree of protection			IP 65
Fixing	Panel-mounted		By clip
	Base-mounted		On socket
Approvals			c UR us, CSA

References



Functions		Multifunction A, Ab, B, C, D, Di, H, T
Timing ranges	7 programmable ranges	99.99 s, 999.99 s, 99 min 59 s, 99.99 min, 999.9 min, 99 h 59 min, 999.9 h
Relay output		1 timed C/O contact
Rated current		5 A
Voltages	--- 12 or 24 V	RE 88 857 502
	\sim 24 or 42...48 V, 50/60 Hz (1)	RE 88 857 504
	\sim 110...127 or 220...240 V, 50/60 Hz	RE 88 857 508
Weight (kg)		0.100
Socket (2)	11-pin	RUZ 1A
	Weight (kg)	0.067

(1) For --- 48V or --- 24 V supply, additional 560 Ω 2 W resistor
(2) These products are sold in packs of 10.

Dimensions and connection scheme

Dimensions

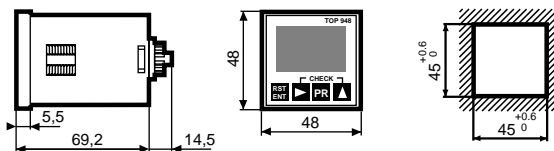

Connection scheme

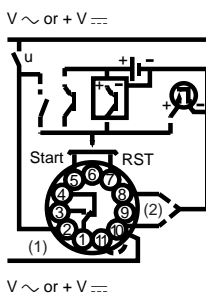

(1) Link between pins 10 and 11 for --- 12 V, \sim 24 V and \sim 110...127 V only.
(2) Link to pin 10 for --- 24 V only.

Display characteristics				
Number of digits			4	
Digit height		mm	8	
Timing characteristics				
Repeat accuracy (with constant parameters)			± 0.03 % ± 20 ms	
Full scale setting accuracy			± 0.03 % ± 20 ms	
Minimum duration of control impulse		ms	50	
Maximum reset time by de-energisation	During time delay period	ms	50	
	After time delay period	ms	50	
Output characteristics				
Relay type			RE 88 857 40●	RE 88 857 10● RE 88 857 00●
Rated current		A	~ 5, --- 5	~ 8, --- 8
Maximum switching voltage		V	~ 250, --- 30	~ 250, --- 30
Maximum breaking capacity on resistive load	~	VA	1250	2000
	---	W	120	190
Maximum permissible current		A	15 < 0.01 s	
Minimum current		mA	100	
Electrical life at I max, ~ 250 V resistive			10 ⁵ cycles	
Mechanical life			5 million operating cycles	
General characteristics				
Permissible voltage variation			- 15...+ 10 %	- 15...+ 10 %
Immunity to microbreaks		s	< 0.03	< 0.03
Maximum power consumption	--- 12 V	W	–	0.5
	--- 24 V	W	0.5	0.5
	--- 48 V	W	–	1
	~ 24 V	VA	1	1
	~ 48 V	VA	–	2
	~ 110 V	VA	3.5	3.5
	~ 220 V	VA	11	11
Temperature limits	Operation	°C	- 10...+ 60	
	Storage	°C	- 30...+ 70	
Front panel degree of protection			IP 65	
Insulation			Conforming to standard VDE 0110 and IEC 225 Group C	
Protection class			Conforming to UTE C 20010, IEC 529, DIN 40050	
Conforming to standards			IEC 255, VDE 0435-2021	
Approvals			c UR us, CSA	
Fixing	Panel-mounted		By clip	
	Base-mounted		On socket	
Material			Self-extinguishing UL 94 grade Vo	

Internal schemes

Relay RE 88 857 40●

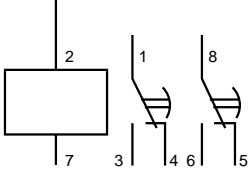

Relay RE 88 857 10●

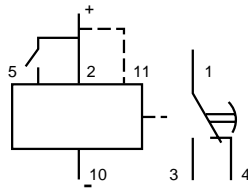

Relay RE 88 857 00●

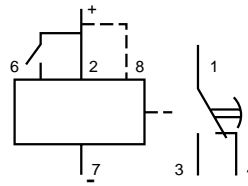

Relay RE 88 857 30●

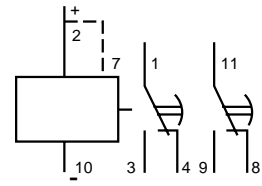

Terminal referencing

Relay
RE 88 57 40●

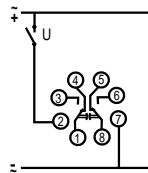

RE 88 857 10●

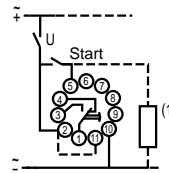

RE 88 857 00●

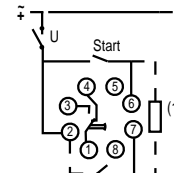

RE 88 557 30●

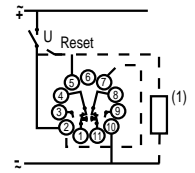

Supply 2-10	-	●	-	●
Supply 2-7	●	-	●	-
Link 2-11 : \sim 12 V or \sim 24 V	-	●	-	-
Link 2-7 : \sim 12 V or \sim 24 V	-	-	-	●
Link 2-8 : \sim 12 V or \sim 24 V	-	-	●	-
2-5 or 2-6 control or reset contact	-	●	●	●
1-3-4 timed output contact	●	●	●	●
8-5-6 timed output contact	●	-	-	-
8-9-11 timed or instantaneous output contact	-	-	-	●

Relay output

- LCD display
- Multifunction or single function
- Multirange
- Multivoltage
- 1 or 2 relay outputs :
- Reset function on front panel (RE 88 857 30●)
- Memory in the event of mains power failure (RE 88 857 30●)
- Locking of access to programming (RE 88 857 10● and RE 88 857 00●)
- Upcount or downcount mode
- Internal supply by lithium battery (10 years at 20 °C)

Function diagrams

Function A

Delay on energisation
1 timed contact

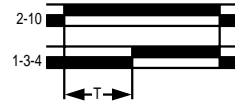

Function A1

Delay on energisation
1 timed contact
1 instantaneous contact

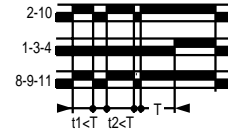

Function A2

Delay on energisation
2 timed contacts

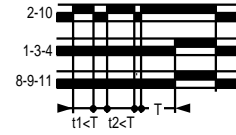

Function AM

Delay on energisation
Memory during the time delay period. Reset

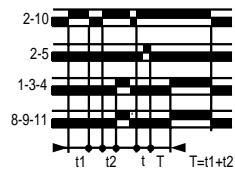

Function AMt

Delay on energisation
Memory during and after the time delay period. Reset

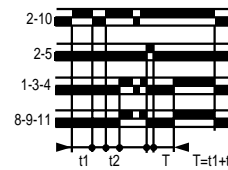

Function B

Timing on impulse, one shot

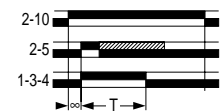

Function C

Off-delay

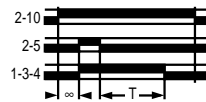

Function D

Flashing relay

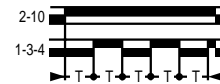

Function Di

Flashing relay

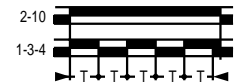

Function H

Timing on energisation

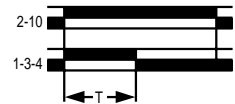

References



Plug-in	8-pin	11-pin	8-pin	11-pin
Functions	Single function A	Multifunction A, B, C, D, Di, H	Multifunction A, B, C, D, Di, H	Multifunction A1, A2, AM, AMt
Timing ranges	99.99 s, 999.9 s, 9999 s, 99 min 59 s, 99.99 min, 999.9 min, 9999 min, 99 h 59 min, 99.99 h, 999.9 h, 9999 h			
Relay output	2 timed C/O contacts	1 timed C/O contact	1 timed C/O contact	1 timed C/O contact 1 timed or instantaneous C/O contact
Rated current	2 x 5 A	8 A	8 A	2 x 8 A
Voltages	$\text{---} 12 \text{ V}$ and \sim or $\text{---} 24 \dots 48 \text{ V}$ –	RE 88 857 103	RE 88 857 003	–
	$\text{---} 12 \text{ V}$ and \sim or $\text{---} 42 \dots 48 \text{ V}$ –	–	–	RE 88 857 302
	\sim or $\text{---} 24 \text{ V}$	RE 88 857 409	–	–
	\sim or $\text{---} 24 \text{ V}$ and $\sim 110 \text{ V}$	–	–	RE 88 857 307
	\sim or c 24 V and $\sim 110 \dots 240 \text{ V}$	–	RE 88 57 05	RE 88 857 005
	\sim or c 24 V and $\sim 220 \dots 240 \text{ V}$	–	–	RE 88 857 301
	$\sim 110 \text{ V}$ $\sim 220 \dots 240 \text{ V}$	RE 88 857 406 RE 88 857 400	–	–
Weight (kg)	0.140	0.100	0.100	0.140
Socket (1)	8-pin	RUZ 1D	–	RUZ 1D
	11-pin	–	RUZ 1A	–
Weight (kg)	0.067	0.067	0.067	0.067

(1) These products are sold in packs of 10

Dimensions

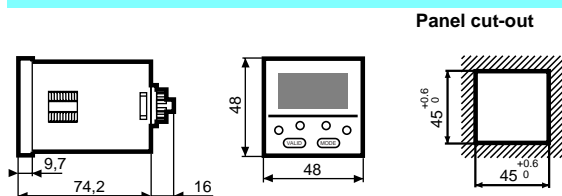

Zelio Time - timing relays

Panel-mounted, plug-in, universal relays

Relay output

- Red illuminated display
- Multifunction
- Multirange
- Multivoltage
- 1 relay output
- Locking of access to programming
- Upcount or downcount mode
- Internal supply by lithium battery (10 years at 20 °C)

Function diagrams

Function A

Delay on energisation
1 timed contact

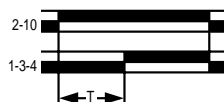

Function B

Timing on impulse, one shot

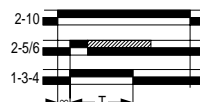

Function C

Off-delay

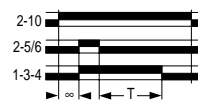

Function D

Flashing relay



Function Di

Flashing relay



Function H

Timing on energisation



References



Plug-in	8-pin	11-pin
Functions	Multifunction A, B, C, D, Di, H	Multifunction A, B, C, D, Di, H
Timing ranges	99.99 s, 999.99 s, 9999 s, 99 min 59 s, 99.99 min, 999.9 min, 9999 min, 99 h 59 min, 99.99 h, 999.9 h, 9999 h	
Relay output	1 timed C/O contact	
Rated current	8 A	
Voltages	or 24 V and or 48 V	RE 88 857 604
	or 24 V and 110 V, 50/60 Hz	RE 88 857 607
	or 24 V and 24...240 V, 50/60 Hz	RE 88 857 601
Weight (kg)	0.100	0.100
Socket (1)	8-pin	RUZ 1D
	11-pin	–
	Weight (kg)	RUZ 1A 0.067

(1) These products are sold in packs of 10

Dimensions

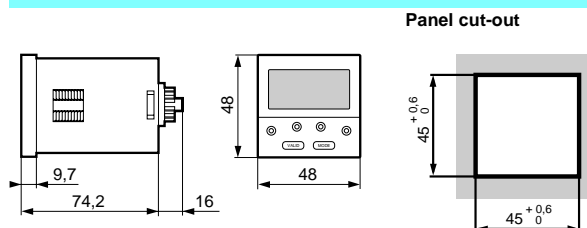

Timing characteristics

Full scale setting accuracy		$\pm 2\%$ ($\pm 5\%$ / 6 s)
Repeat accuracy		$\pm 1.5\%$ ($\pm 4\%$ / 6 s)
Selection precision		See table "timing range scale graduation" on page opposite
Max. reset time	s	0.20

Output characteristics

Output type		1 timed C/O contact and + 1 N/O instantaneous contact
Thermal current	A	6.3
Breaking capacity (cos $\phi = 0.41$) 10 000 operating cycles		5 A - 230 V

General characteristics

Permissible voltage variations at maximum temperature of 55 °C conforming to standard IEC 255-100	24 V 42...48 V 110...127 V 220...240 V		+ 10 % - 15...+ 10 % - 20...0 % - 20...0 %
Motor power consumption		VA	3 for Cos ϕ 0.8
On-load factor			100 %
Temperature limits	Operation Storage	°C	- 10...+ 55 - 20...+ 70
Environmental protection			Tropicalisation conforming to standard IEC 68-2-10
Vibration withstand on 3 axes (Veritas standards)			4 gn - 55 Hz
Dielectric test voltage conforming to standards IEC 255-5 or VDE 0435		V	Un \leq 60 : 1000 Un > 60 : 2000
Insulation voltage	Conforming to standard VDE 0110 Group C	V	\sim 380, \equiv 440
Degree of protection	Enclosure Terminal block		IP 40 IP 10
Conforming to standards			NFC 45250-VDE 0110-0435-0660 or IEC 529
Approvals			CSA, UR only for RE 88 826 011, RE 88 826 014, RE 88 826 504 and RE 88 826 508
Connection			Screw clamps
Clamping capacity	1 or 2 single-strand wires 1 or 2 multi-strand wires	mm ²	0.75...2.5 0.5...1
Fixing			Base-mounting on 8-pin socket

Internal schemes

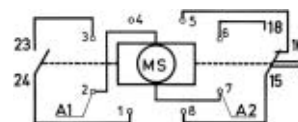
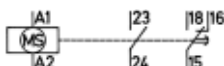

Terminal referencing

Relay RE 88 226 0●●

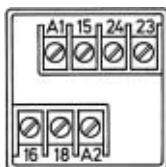

Relay RE 88 226 50●

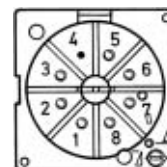

A1-A2 supply	●	-
15-16-18 timed contact	●	-
23-24 instantaneous contact	●	-
2-7 supply	-	●
8-5-6 timed contact	-	●
3-1 instantaneous contact	-	●

Relay output

- Multifunction
- Multirange
- Single voltage
- 1 timed C/O contact and 1 instantaneous contact
- Elapsed time can be saved mechanically in the event of a power failure
- Indication of cycle progress
- Enclosure 48 x 48 mm
- Connection by screw terminal block or 8-pin base fitting

Function diagrams

Function n° 2

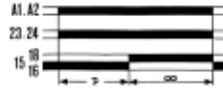

Function n° 3



Function n° 4



References



Functions		Multifunction	Multifunction	Multifunction	Multifunction
		2, 3, 4 (1)	2, 3, 4 (1)	2, 3, 4 (1)	2, 3, 4 (1)
		(1) Function n° 4 : on energisation, chance of contact bounce on instantaneous contact for 250 ms			
Timing ranges	3 ranges	6 s, 60 s, 12 min	6 min, 60 min, 12 h	6 s, 60 s, 12 min	6 min, 60 min, 12 h
	Max. timing	12 min	12 h	12 min	12 h
	Dial graduations	0.1 s, 1 s, 12 s	6 s, 1 min, 12 min	0.1 s, 1 s, 12 s	6 s, 1 min, 12 min
Relay output		1 timed C/O contact, 5 A 1 inst. contact	1 timed C/O contact, 5 A 1 inst. contact	1 timed C/O contact, 5 A 1 inst. contact	1 timed C/O contact, 5 A 1 inst. contact
Voltages	24 V 50 Hz	RE 88 226 013	RE 88 226 016	RE 88 226 501	RE 88 226 505
	42...48 V 50 Hz	RE 88 226 019	RE 88 226 017	RE 88 226 502	RE 88 226 506
	110...127 V 50 Hz	RE 88 226 012	RE 88 226 015	RE 88 226 503	RE 88 226 507
	220...240 V 50 Hz	RE 88 226 011	RE 88 226 014	RE 88 226 504	RE 88 226 508
Weight (kg)		0.185	0.185	0.185	0.185

Dimensions and connection schemes

Dimensions

Relay RE 88 226 0●●

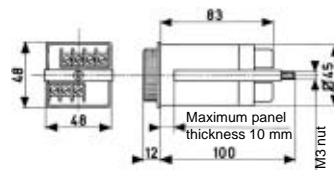

Relay RE 88 226 50●

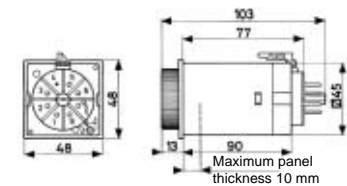

Panel cut-out

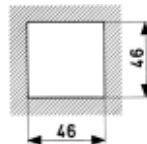

Connection schemes

Function n° 2

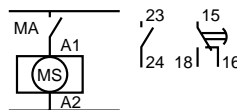

Function n° 3

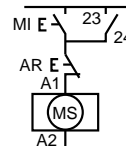

Function n° 4

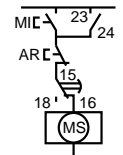

Timing characteristics

Full scale setting accuracy		± 4 %
Selection precision		See table "timing range scale graduation" on page opposite

Output characteristics

Relay type		2 C/O contacts
Thermal current	A	20
Mechanical life		> 10 million operating cycles
Breaking capacity (cos φ = 0.41)	10 000 operations	16 A - 230 V

General characteristics

Permissible voltage variations at max. temperature of 55 °C conforming to standard IEC 255-1-00		-15...+10 % Un
Motor power consumption	VA	3.1 for Cos φ 0.8
On-load factor		100 %
Temperature limits	Operation	°C - 5...+ 70
	Storage	°C - 40...+ 80
Environmental protection		Metal parts protected Insulated motor coil
Vibration withstand on 3 axes (Veritas standards)		4 gn - 55 Hz
Dielectric test voltage conforming to standards IEC 255-5 or VDE 0435	V	Un ≤ 60 : 1000
	V	Un > 60 : 2000
Insulation voltage conforming to standard VDE 0110 Group C	V	~ 380, --- 440
Degree of protection	Terminal block	IP 10
Connection	Tag connector	6.35 mm
	Motor wires	mm 250
Fixing	Screw	2 x M3 - 2 x M4

Internal scheme

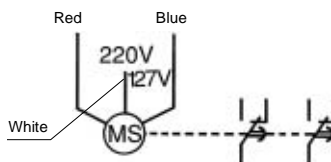

Relay output

- Single function
- Single range
- Single voltage
- Manual reset
- Indication of cycle progress
- 2 C/O contact output (16 A max per contact)
- Multi-fixing

Function

2-pole

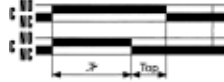

References



Functions		Single function							
Timing ranges	1 model per range	5 min,	15 min,	30 min,	60 min,	120 min,	5 h,	15 h,	30 h
	Maximum timing	4 min 40 s,	14 min,	28 min,	56 min,	1 h 53 min,	4 h 43 min,	14 h 10 min,	28 h 20 min
	Dial graduations	15 s,	30 s,	1 min,	2 min 30 s,	5 min,	5 min,	30 min,	1 h
		Average duration of pulse between changeover of the 2 timed contacts : 3 % of the maximum timing							
Relay output	2 timed relays								
Breaking capacity per contact	16 A								
Voltages : ~ 127...230 V 50 Hz	5 min	RE 88 256 506							
	15 min	RE 88 256 507							
	30 min	RE 88 256 508							
	60 min	RE 88 256 509							
	120 min	RE 88 256 510							
	5 h	RE 88 256 511							
	15 h	RE 88 256 512							
30 h	RE 88 256 513								
Weight (kg)	0.225/245								

Dimensions and connection schemes

Dimensions

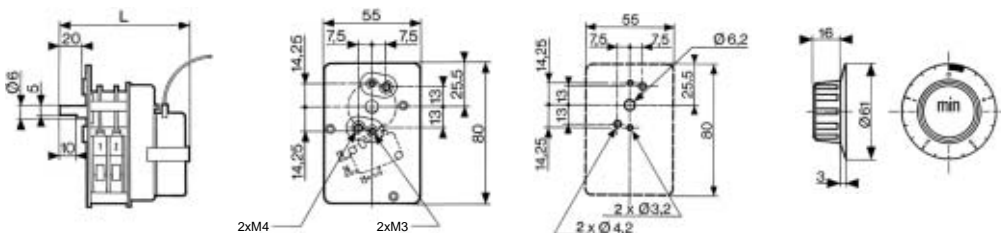

Panel cut-out

Connection schemes

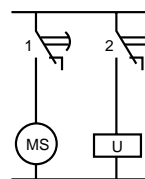
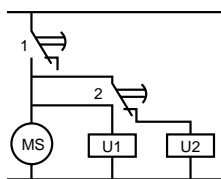

Timing characteristics

Precision limit error		$\pm 2\%$ ($\pm 5\%$ / 6 s)
Repeat accuracy		$\pm 1.5\%$ ($\pm 4\%$ / 6 s)
Selection precision		See table "timing range scale graduation" on page opposite
Reset time	s	0.20
Memorisation of time delay		By means of switch on rear of device

Output characteristics

Timed 2-pole		1
Instantaneous single-pole		1
Thermal current	A	6.3
Breaking capacity ($\cos \varphi = 0.41$)	10 ⁴ operations	5 A - 230 V

General characteristics

Permissible voltage variations at a maximum temperature of 55 °C Conforming to standard IEC 255-100	24 V		+ 10 %
	42...48 V		- 15...+ 10 %
	110...127 V		- 20...0 %
	220...240 V		- 20...0 %
Motor power consumption		VA	$\cos \varphi 0.7 : 3$
On-load factor			100 %
Temperature limits	Operation	°C	- 10...+ 55
	Storage	°C	- 20...+ 70
Environmental protection			Tropicalisation conforming to standard IEC 68-2-10
Vibration withstand on 3 axes	Veritas standards		4 gn - 55 Hz
Dielectric test voltage	Conforming to standards IEC 255-5 or VDE 0435	V	Un ≤ 60 : 1000 Un > 60 : 2000
	Conforming to standard VDE 0110 group C	V	~ 380, ≡ 440
Degree of protection	Enclosure		IP 40
	Terminal block		IP 10
Conforming to standards			NFC 45250-VDE 0110-0435-0660 or IEC 529
Approvals			CSA, UR only for RE 88 225 011 and RE 88 225 014
Connection			By screws in front panel with self-lifting grips
Clamping capacity	Single-strand	mm²	1 or 2 x 0.75...2.5
	Multi-strand with self-crimping cable ends	mm²	1 or 2 x 0.75...2.5
Fixing	Screw		2 x M5
	Clip-on		On EN 50022 mounting rail

Internal scheme

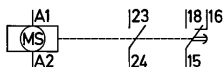

Relay output

- Multifunction
- Multirange
- Single voltage
- 1 timed C/O contact and 1 instantaneous contact
- Elapsed time can be saved mechanically in the event of a power failure
- Indication of cycle progress
- Enclosure for mounting on symmetrical mounting rail

Function diagrams

Function n° 2

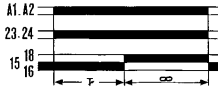

Function n° 3



Function n° 4



References



Functions	Multifunction	Multifunction
	2 - 3 - 4 (1)	2 - 3 - 4 (1)
	(1) Function n° 4 : on energisation, chance of contact bounce on instantaneous contact for 250 ms	
Timing ranges	3 ranges Dial graduations	6 s, 60 s, 12 min 0.1 s, 1 s, 12 min
Relay output	1 timed C/O contact, 5 A 1 instantaneous N/O contact	6 min, 60 min, 12 h 6s, 1 min, 12 min 1 timed C/O contact, 5 A 1 instantaneous N/O contact
Voltages	~ 24 V - 50 Hz ~ 42...48 V - 50 Hz ~ 100...127 V - 50 Hz ~ 220...240 V - 50 Hz	RE 88 225 013 RE 88 225 019 RE 88 225 012 RE 88 225 011
Weight (kg)	0.185	RE 88 225 016 RE 88 225 017 RE 88 225 015 RE 88 225 014 0.185

Dimensions and connection schemes

Dimensions

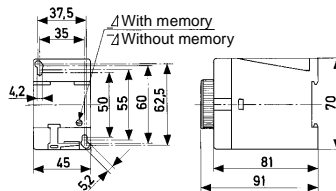

Terminal referencing

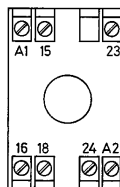

- A1-A2 Supply
- 15-16-18 Timed contact
- 23-24 Instantaneous contact

Connection schemes

Function n° 2

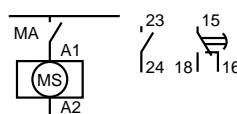

Function n° 3

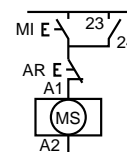

Function n° 4

