

Low power distribution

Canalis KN busbar trunking (40 to 100 A)

For distribution in craft workshops, industrial workshops and hypermarkets.

Main lighting distribution feed runs for secondary runs.

Presentation

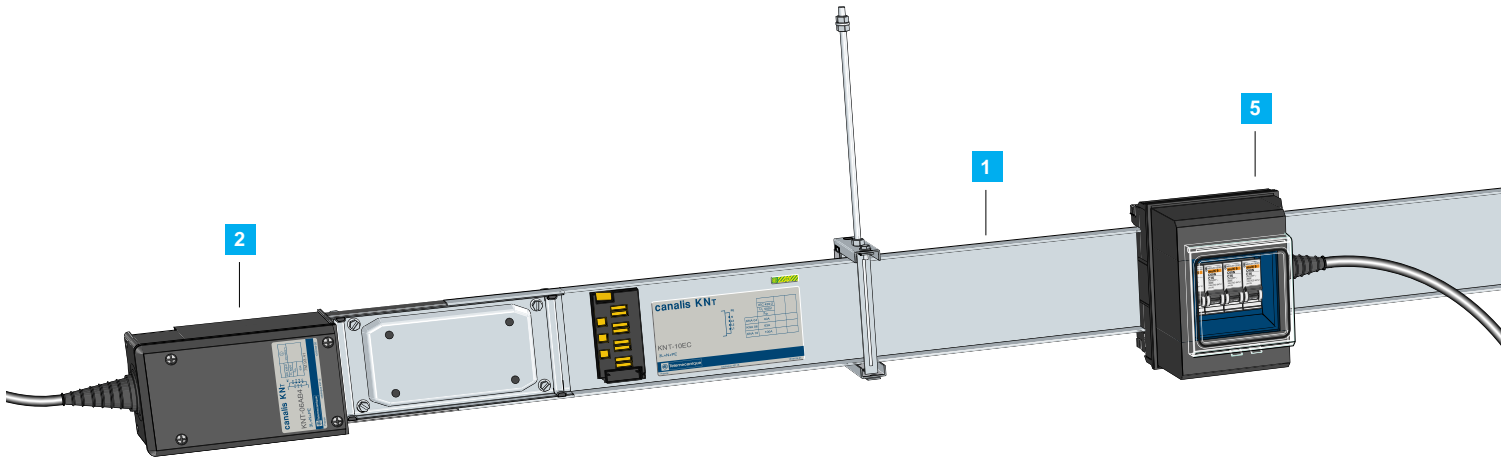

1

Run components

3 power ratings : 40, 63 or 100 A.
4 live conductors. 3 and 2 m in length.

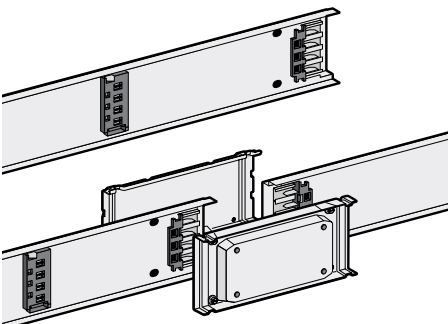

2

Feed units and end covers

Feed the KN trunking from either
one of the two ends or along a run.

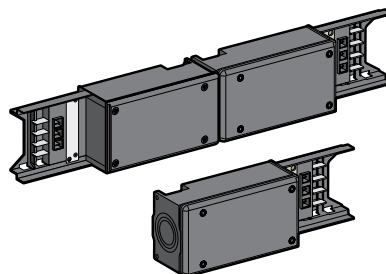

3

Components for changing direction

Adapt the Canalis KN to the requirements of the
installation : elbow fittings, flexible lengths.

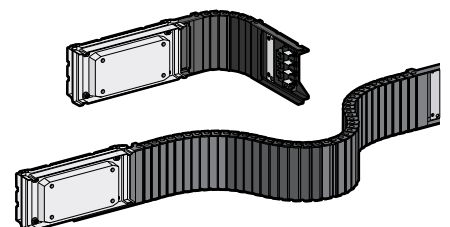

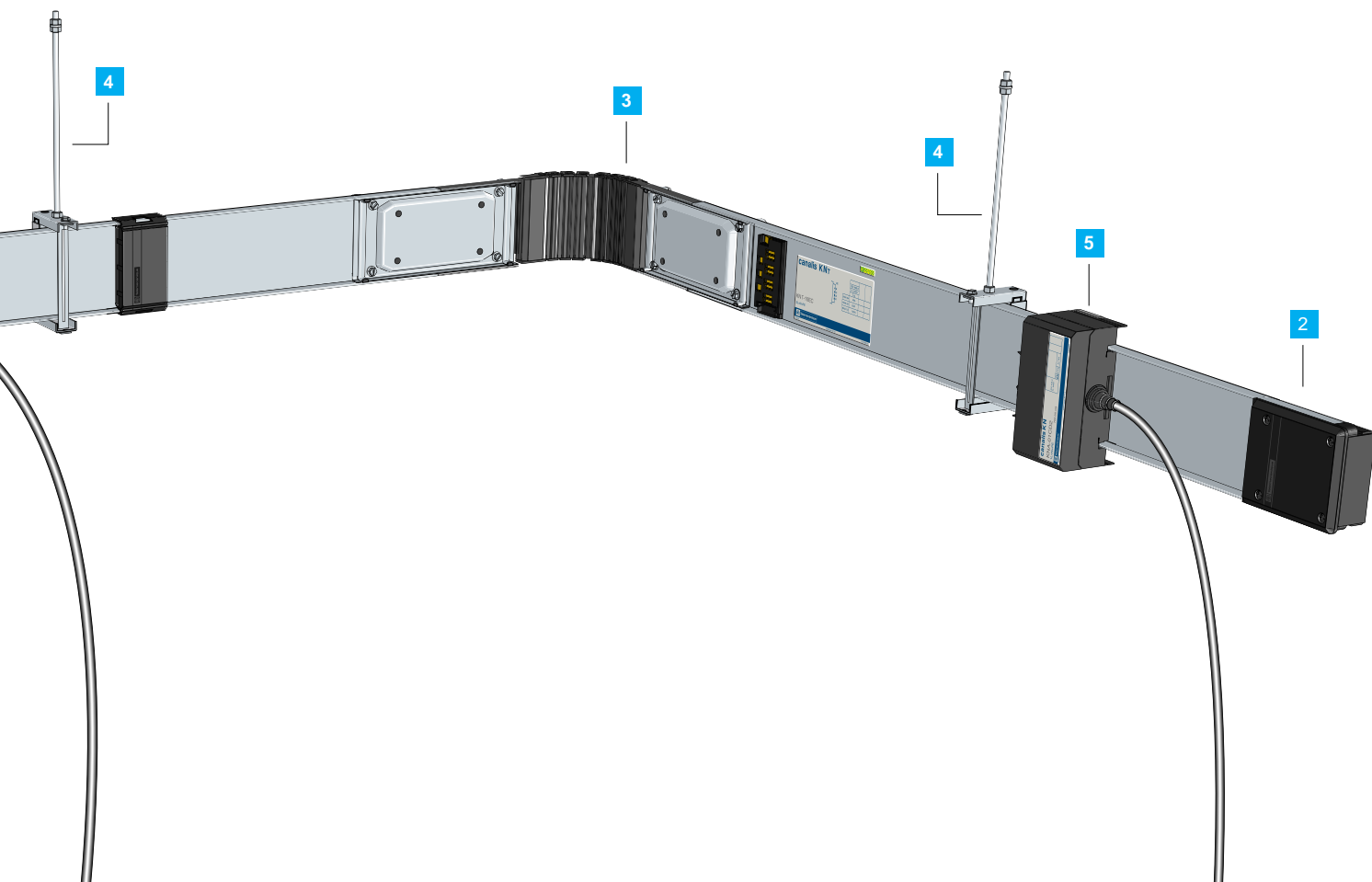

4

Fixing devices

Fix the KN trunking.

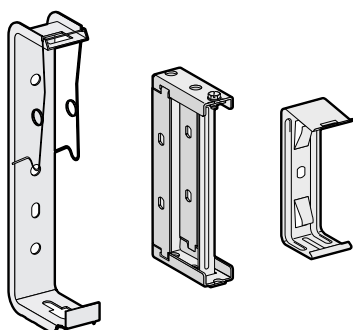

5

Tap-off units

16 to 40 A connectors and tap-off units with isolator for fuse or modular fittings.

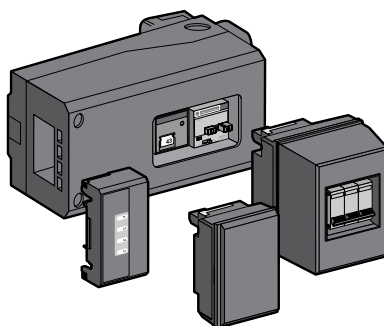

6

Accessories

Provide IP 54 protection.

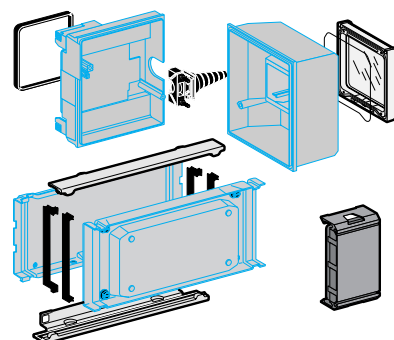

Low power distribution

Selection guide :
page 11022/2
Characteristics :
page 11022/3
References :
pages 11023/3 to 11028/3
Dimensions :
pages 11029/2 and 11029/3

Canalis KN (40 to 100 A)

Description

Canalis KN is designed for low power distribution. There are two versions :
- Canalis KNA : busbar trunking with 4 live conductors (3L + N + PE), for distribution up to 100 A.
- Canalis KNT : identical to the KNA trunking, but also fitted with a remote transmission bus with three 2.5 mm² conductors.
This bus enables automated electrical distribution using K-System or BatiBUS.
KNA and KNT busbar trunking provides IP 41 degree of protection as standard, or IP54 with accessories. As a general rule, Canalis KN is manufactured according to TC specifications (TC = all climates). All insulation and plastic materials used have improved fire-resistance : incandescent wire test withstand ≥ 850 °C (IEC 695-2-1).

Straight lengths

To carry the current and feed low power loads.

The run structure is made up of straight lengths which comprise :

- 1 A hot galvanized crimped sheet steel totally closed carrier mounting rail. This mounting rail also acts as the protected earth conductor (PE).
- 2 A Noryl insulated mounting rail, supporting the live conductors.
- 3 4 live aluminium conductors fitted with contacts consisting of silver-plated aluminium/copper bimetal strips at junctions and tap-off units.
- 4 Tap-off points with plug flaps which can be opened and closed automatically by installing or removing a connector or tap-off unit. 1 or 2 tap-offs per metre depending on the version used.
- 5 A mechanical and electric jointing device. Electrical connection is via flexible grip contacts in silver-plated copper. It ensures the automatic and simultaneous interface of all live conductors and provides protected earth conduction.
- 6 3 copper bus conductors (Canalis KNT).

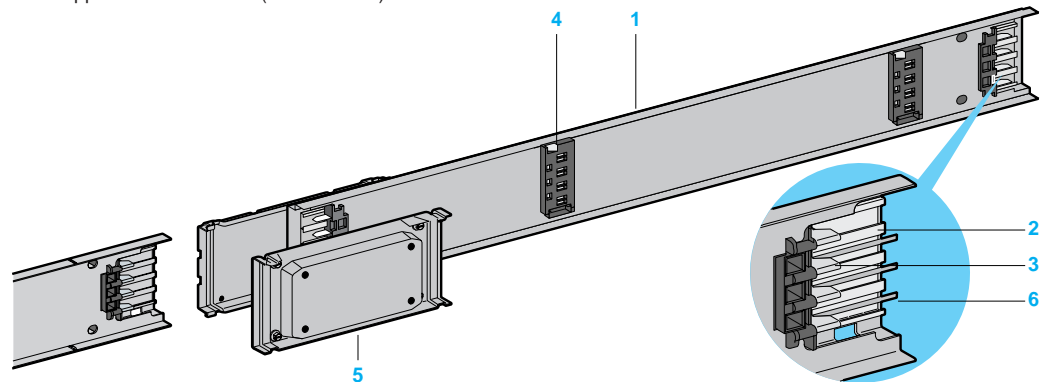

Feed units

To feed a Canalis KN run with cable. They can be mounted at the end of the straight length (end feed) or in the middle or the run (central feed).

These units, in diecast material, are fitted with :
- terminals for 16 mm² copper cables for 63 A feed units, and copper contacts for 35 mm² connectors for 100 A feed units.
- multi-diameter knock-out entry for mounting a cable gland (not supplied).
- a 3 x 2.5 mm² terminal block for connecting the remote transmission cable (Canalis KNT).

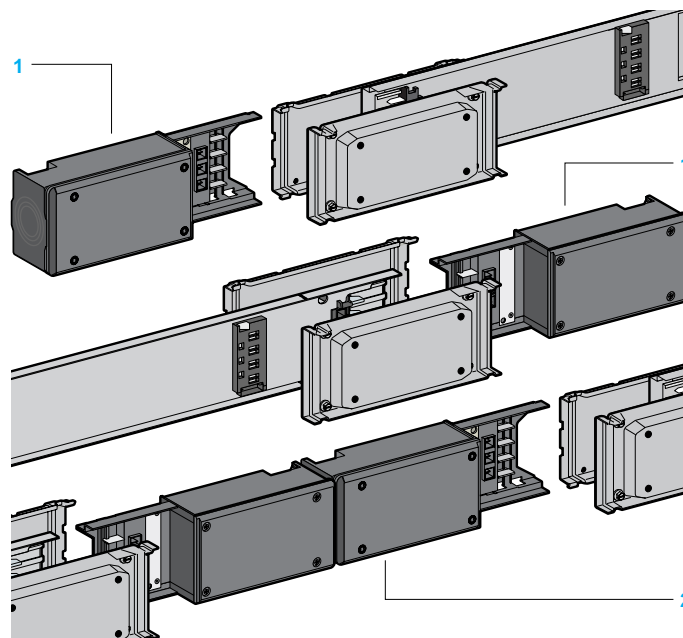

1 End feed units
These are fitted with a mechanical and electrical locating device (polarization), enabling a run to be fed from the left or the right. They are supplied with 1 end cover.

2 Central feed units
These are supplied with 2 end covers.

Low power distribution

Selection :
 page 11022/2
 Characteristics :
 page 11022/3
 References :
 pages 11023/3 to 11028/3
 Dimensions :
 pages 11029/2 and 11029/3

Canalis KN (40 to 100 A)

Description

Components for changing direction

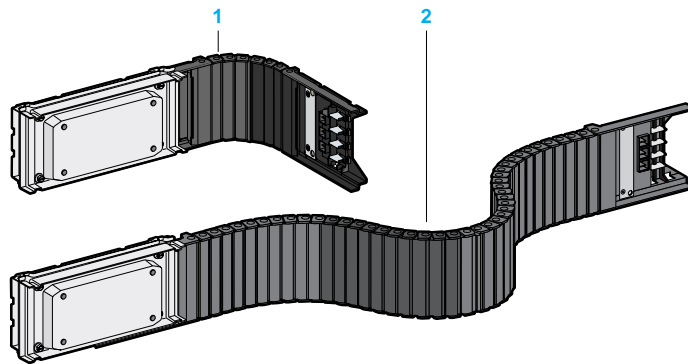

To change direction, clear an obstruction (pillars, pipes) etc. Flexible to handle, can be adapted to any form on site. Minimum flexible radius : 70 mm.

- 1 Flexible elbow
- 2 Flexible length
 1 m long, they can extend along 3 walls without resorting to an element of any specific length, regardless of the dimensions of the premises.

Example of use :

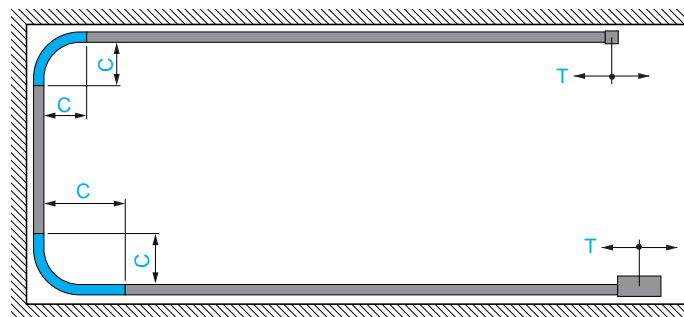

- C These dimensions can be adjusted on-site from 200 mm to 850 mm, by means of flexible lengths.
- T These dimensions represent the installation clearance at the ends of the run.

Fixing devices

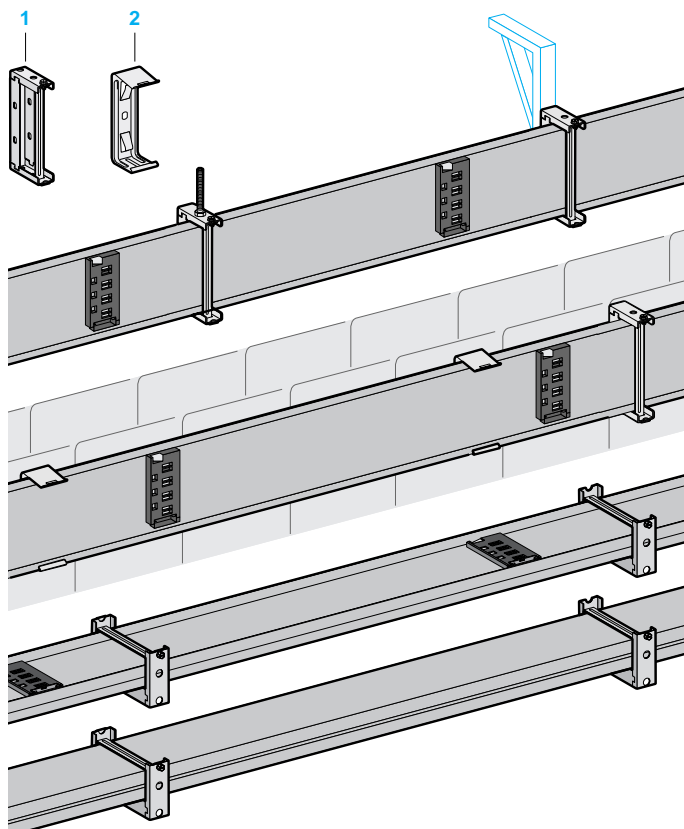

To fix the run to the structure of the building, either directly or by using a threaded rod (\varnothing 8 mm), bracket, etc.

These fixing brackets are suitable for all fixing methods : ceiling, suspended, wall, partition wall, etc.

Suspension by chain or steel cable is not recommended.

- 1 Universal clip-on fixing brackets
 For edgewise or flat trunking installation. The recommended fixing distance is 3 m for edgewise mounted trunking and 1.5 m for flat mounted trunking.
- 2 Wall brackets
 For edgewise and partition wall trunking installation only. The recommended fixing distance is 2 m.

Low power distribution

Selection :
 page 11022/2
 Characteristics :
 page 11022/3
 References :
 pages 11023/3 to 11028/3
 Dimensions :
 pages 11029/2 and 11029/3

Canalis KN (40 to 100 A)

Description

Connectors and tap-off units

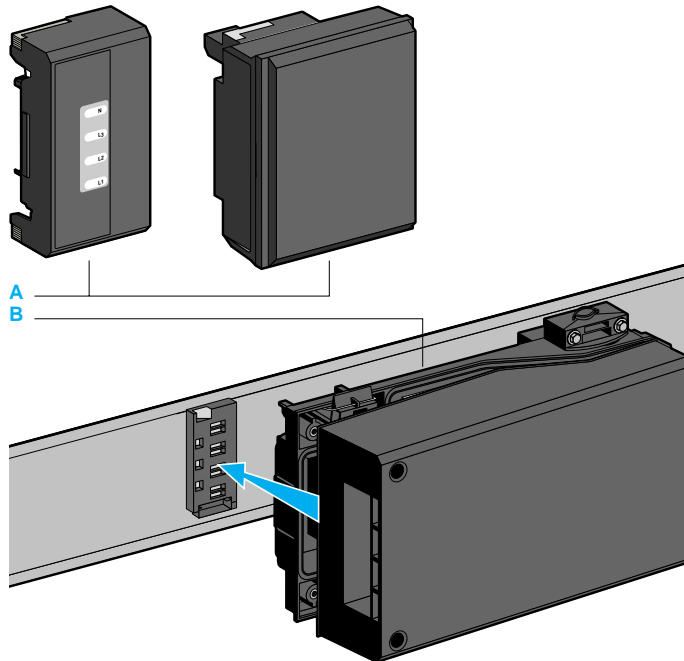

For rapid connection of loads or secondary runs (lighting for example), conforming to installation standards and rules concerning neutral conditions TT, IT and TNS. For condition TNC : please consult your Regional Sales Office.

They can be moved while powered, when not loaded. All contacts are made on silver plated copper.

A Connectors
 Disconnect by unplugging the connector.
 The electrical equipment and the connection terminals can only be accessed when the connector is unplugged (not powered).
 A safety device prevents plugging on to the trunking when the cover is open.

B Box with breaker switch
 The AC 20 is disconnected by opening the door of the box.
 Several safety devices prevent :
 - plugging in the unit, door closed,
 - closing the door when the unit is not screwed to the trunking,
 - unplugging the unit, door closed.

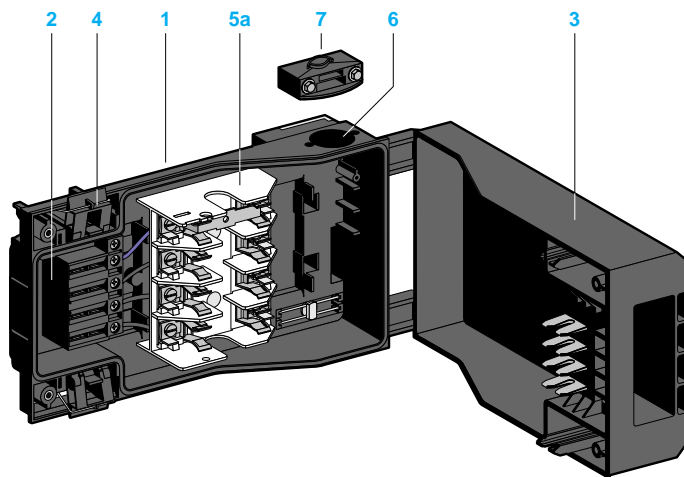

1 Moulded plastic casing
2 Power socket
3 Door fitted with isolating links.
4 Trunking locking device (4 points).
5 Equipment
 - **5a** : for fuses,
 - **5b** : for modular equipment.
6 Knock-out cable exits
7 Cable clamp

All tap-off units with isolator are manufactured in version KNA (without a remote transmission bus). They are converted to KNT by adding a "add-on bus connection block", to be ordered separately.

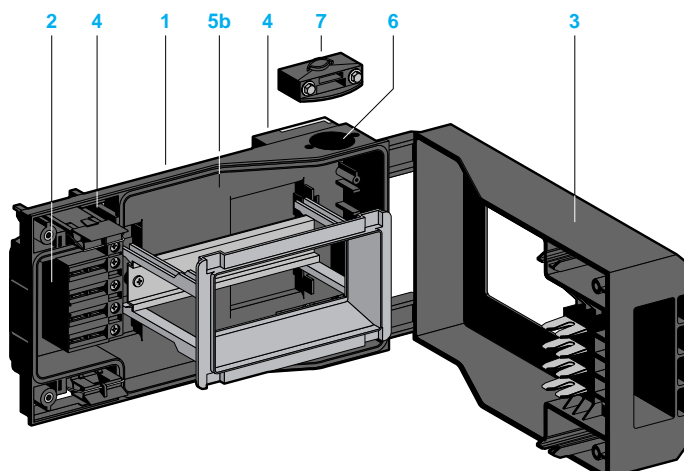

Low power distribution

Selection :
page 11022/2
Characteristics :
page 11022/3
References :
pages 11023/3 to 11028/3
Dimensions :
pages 11029/2 and 11029/3

Canalis KN (40 to 100 A)

Description

Single phase connectors with phase selection

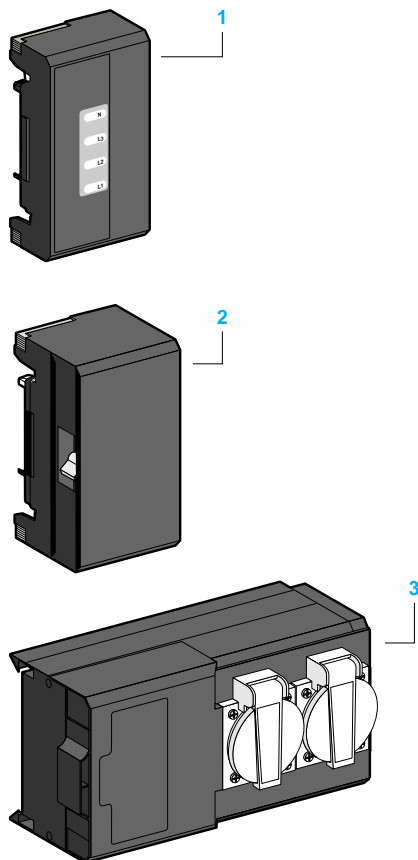

They are fitted with a selection system which can be used to choose the phase : L1, L2 or L3 + N + PE.

These connectors are available in three versions :

- 1 Connector with fuse carrier
For protection of the tap-off by fuse (not supplied). It is fitted with carriers for the following fuses :
 - NF 8.5 x 31.5, type gF, 16 A maximum.
 - BS 88A1, 20 A maximum.
- 2 Connector with circuit-breaker
For protection of tap-off using circuit breaker. It is fitted with a Merlin Gerin circuit breaker, type C60N, 1 pole, curve C.
- 3 Connector with circuit breaker and power socket(s)
It is fitted with :
 - a Merlin Gerin circuit breaker, 1 pole or 1 pole + N,
 - one or two power sockets complying to European domestic standards (NF, DIN/VDE, BS, CEPEC, etc.).

The circuit breaker cuts out automatically when the connector is unplugged.

Connectors 3L + N + PE

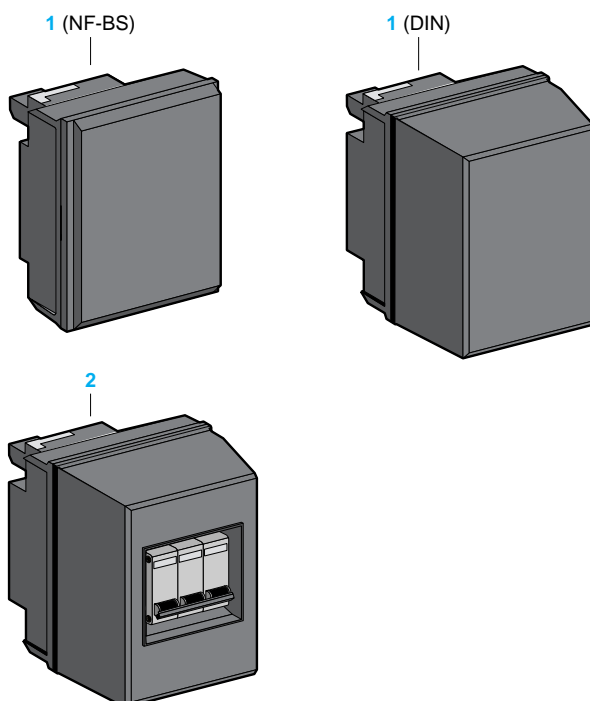

- 1 Connectors with fuse carriers.
For protection of tap-off units using fuses (not supplied). They can be fitted with fuse carriers for :
 - NF 10 x 38, type gG, 20 A or aM, 25 A fuses.
 - BS, type 88A1, 20 A fuses.
 - DIN, type Neozed D01, 16 A fuses.

- 2 Connector for modular equipment.
This enclosure will accept the majority of modular equipment at 17.5 mm intervals.
Rated current : 25 A.
Maximum capacity : 4 modules.
(or 8 for 9 mm centres)

It is available :

- in KNA version (without remote transmission bus) or KNT (with remote transmission bus),
- with window and front cover, (equipment visible and accessible),
- or full cover (equipment not accessible when powered up).

Low power distribution

Selection :
page 11022/2
Characteristics :
page 11022/3
References :
pages 11023/3 to 11028/3
Dimensions :
pages 11029/2 and 11029/3

Canalis KN (40 to 100 A)

Description

Tap-off units with isolator

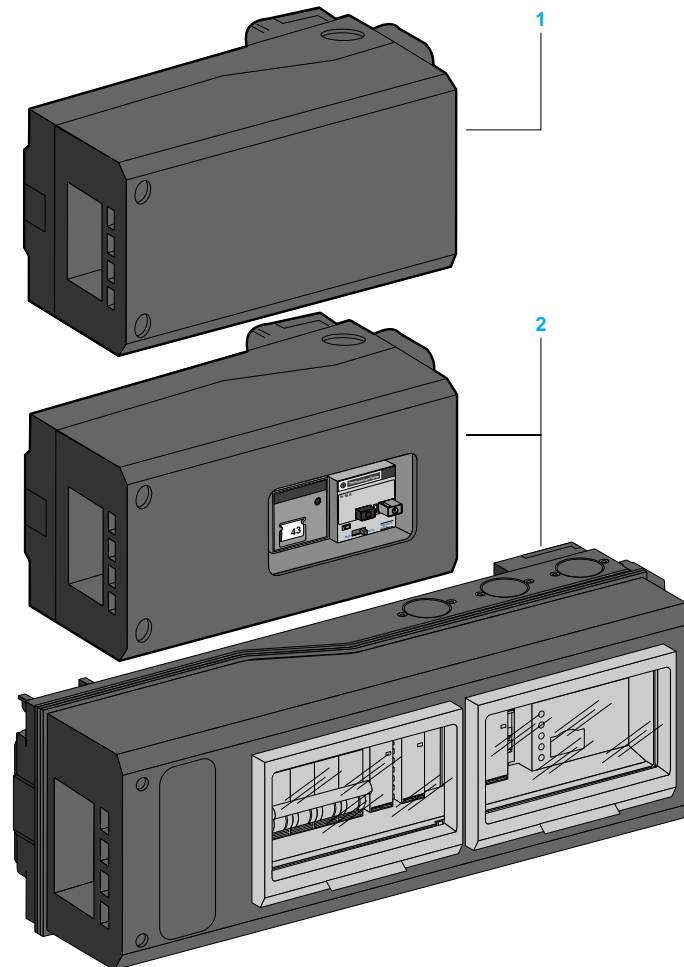

1 Tap-off unit with isolator and fuse carrier for protection of the tap-off by fuses (not supplied). It can be fitted with carriers for the following fuses :
- NF 14 x 51, type gG, 32 A or Am, 40 A.
- BS type 88A1, 30 A.
- DIN type Diazed E27 25 A, or Neozed D02, 35 A.
The version for NF fuses can accept a single-phase operation safety device. In IT scheme, distributed neutral, this device is linked to a single pole switch which is placed downstream of the tap-off, to protect the neutral conductor.

2 Tap-off units with isolator for modular equipment
They can accept the majority of modular equipment at intervals of 17.5 mm. Rated current : 40 A.
3 sizes available : 7 modules, 2 x 7 modules or 16 modules.

They are available with window(s) and front cover(s), (equipment visible and accessible), or complete cover (equipment is not accessible when powered up).

The equipment rating must take into account :
- maximum current, 40 A (protection using circuit breaker),
- possible derating recommended by the manufacturers, when installing several units side by side in an enclosure.

Add-on bus connection block

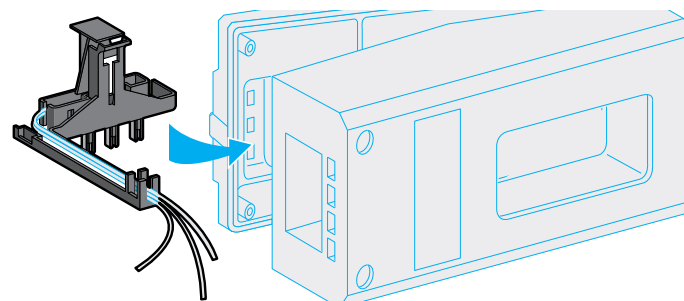

To tap-off the KNT bus.

Clips on to all tap-off units with isolator, the device allows the equipment to be controlled by K-System or BatiBUS.

Sealing accessories

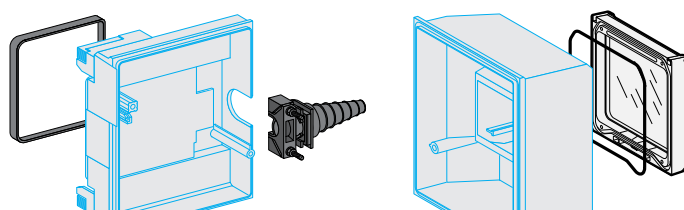

To increase the standard degree of protection (IP41) to IP54.

They are supplied in sachets containing the necessary parts for fitting to a connector or to a tap-off unit with isolator.

Low power distribution

Selection :
page 11022/2
Characteristics :
page 11022/3
References :
pages 11023/3 to 11028/3
Dimensions :
pages 11029/2 and 11029/3

Canalis KN (40 to 100 A)

Description

Accessories

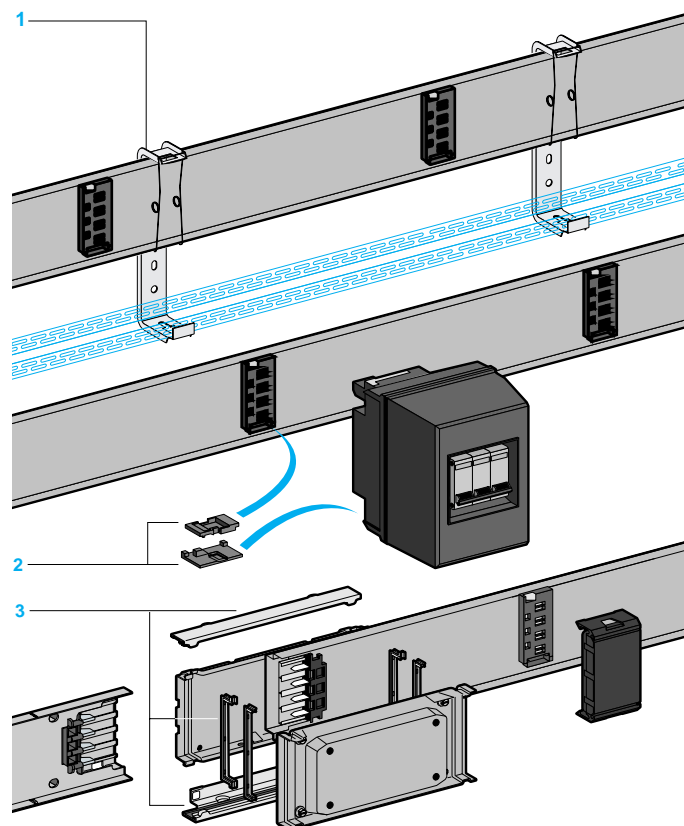

- 1 Bracket for ducting or cable racks. Mounted by clipping onto straight lengths. It enables additional ducting or cable rack to be mounted (maximum width 50 mm).
- 2 Locating device system. To define and separate up to 4 networks which differ in voltage, frequency, etc.
- 3 Sealing accessories. To increase the standard degree of protection (IP41) to IP54. These accessories are to be provided in the following conditions :
 - extremely dusty (woodwork, etc.),
 - humid and/or where there is a risk of frequent condensation,
 - subjected to splashing water.

Flexible elbows and components cannot be made dust and damp proof using these accessories. An IP54 version common to KNA and KNT trunking (remote transmission bus systematically integrated) is available.

Mounting and assembling

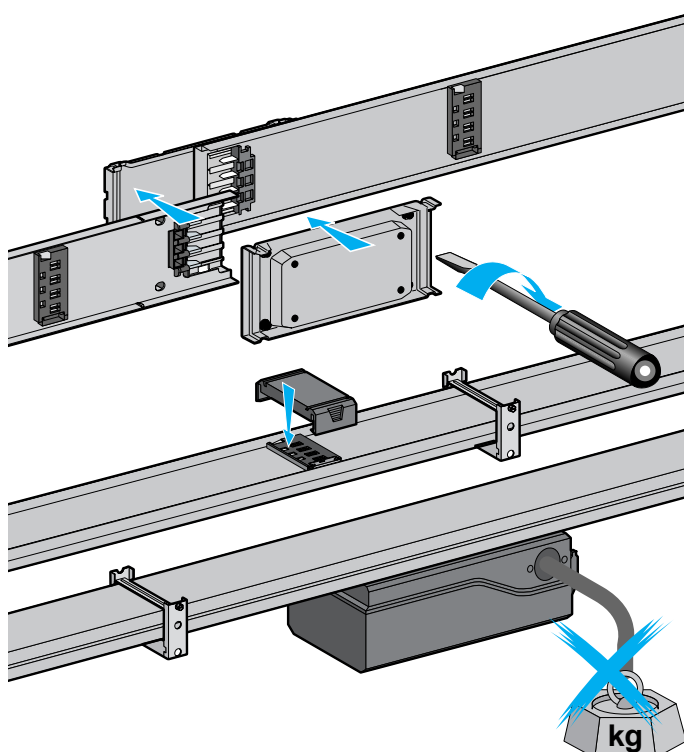

Assembly is by simple a snap-on action and then locked. Locating devices prevent any operating or connection errors.

The recommended distance between fixing depends on the type of brackets used and on the mounting position of the trunking :

- edgewise mounting using universal bracket, 3 m maximum,
- partition mounting using clip-on bracket, 2 m maximum,
- flat mounting using universal brackets, 1.5 m maximum.

The average installation time for a run is - 0.30 h/linear metre.

Precautions where KN trunking is flat mounted :

- Tap-off units mounted above. The degree of protection is limited to IP 40 for standard version and IP 51 using accessories. When there is a risk of grease and dust deposits, place a blanking plate on the unused tap-off units.
- Tap-off units mounted below. The feed cables to the loads must not exert any pressure on the unit.

Low power distribution

Description :
pages 11021/2 to 11021/7
Characteristics :
page 11022/3
References :
pages 11023/3 to 11028/3
Dimensions :
pages 11029/2 and 11029/3

Canalis KN busbar trunking (40 to 100 A)

Selection guide

Information required

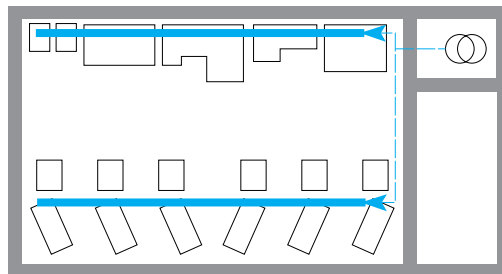

- Type, characteristics and location of load.
- Characteristics and location of power source.
- Structure of the premises (to establish the availability of suitable fixing points).
- External factors (ambient air temperature, dust, damp, etc., where the trunking is to be installed).
A single distribution run serves an area 4 to 6 metres wide.
Where distribution runs are installed depends on the location of loads, position of the general power supply and availability of suitable fixing points.

Busbar trunking selection according to rated operating current I_b

Calculation of rated operating current I_b and trunking selection : $I_{\text{total}} \times k_1 = I_b$

I_{total} : Sum of currents drawn by loads on the run.

k_1 : Average demand coefficient (general engineering workshops).

Applications	k_1	Rated operating current I_b	Trunking selection
Lighting, heating	1	< 40 A	KN●-04
2 or 3 loads	0.9	from 40 to 62 A	KN●-06
4 or 5 loads	0.8	from 63 to 99 A	KN●-10
6...9 loads	0.7		
10...40 loads	0.6		

Permissible current I_z according to ambient air temperature (at installation site)

The nominal current of the busbar trunking (I_{nc}) is specified for an average ambient daily air temperature of 35 °C (and maximum of 40 °C).

A derating or uprating factor (f_1) may be applied to this nominal current, depending on the actual temperature : see next page.

Checking the voltage drop

The voltage drop in the Canalis KN trunking is shown in V/100 mA in the characteristics table on the next page.

Protection against trunking overload

So as to allow for any extensions, prefabricated trunking is generally protected at its nominal current I_{nc} (or at its permissible current I_z if coefficient f_1 is applied as above).

Depending on the type of protection, calculate the standard nominal current (I_n) of the overload device so that :

$$I_n \leq \frac{I_{nc}}{k_2}$$

k_2 = coefficient depending on the type of protection

- $k_2 = 1$ Protection by circuit-breaker
- $k_2 = 1,1$ Protection by gG fuse

Select either the same or next lowest **standard** I_n rating.

It is advisable to check that $I_n \geq I_b$. If this is not so, select the next highest trunking rating.

Note : In effect, protection by gG fuses limits the rated operational current.
Protection by circuit-breaker allows the trunking to be used at full capacity.

Protection against short-circuits and accidental contact

The "Guide of Precalculated Projects" (CanGEP), is a quick and simple reference source for quickly and accurately establishing the trunking (Canalis and cables) and their protection characteristics in complete conformity with the standard NF C 15100.

Please consult your Regional Sales Office.

Automation using K-System.

Please consult your Regional Sales Office.

Low power distribution

Description :
pages 11021/2 to 11021/7
Selection :
page 11022/2
References :
pages 11023/3 to 11028/3
Dimensions :
pages 11029/2 and 11029/3

Canalis KN busbar trunking (40 to 100 A)

Characteristics

Type of trunking			KNA-04/KNT-04	KNA-06/KNT-06	KNA-10/KNT-10
------------------	--	--	---------------	---------------	---------------

General characteristics

Conforming to standards			IEC 439-2 and EN 60439-2		
Number of live conductors			4	4	4
Nominal rated current Inc (at average ambient temperature 35 °C)	Inc	A	40	63	100
Type of current/rated frequency	F	Hz	~ 50/60	~ 50/60	~ 50/60
Rated insulation voltage	Ui	V	500	500	500
Rated operating voltage	Ue	V	24...500	24...500	24...500
Degree of protection to IEC 529	IP of construction IP with dust & damp proofing accessories		IP 41 IP 54		

Conductor characteristics

Live conductors (per conductor)					
Average resistance, cold state (ambient temperature 20 °C)	R20 - Rb0ph (1)	mΩ/m	4.75	1.90	0.81
Average resistance at Inc (ambient temperature 35 °C)	R1 - Rb1ph (1)	mΩ/m	5.47	2.21	0.93
Average reactance at Inc and at rated Frequency (Hz)	X1 - Xph (1)	mΩ/m	0.20	0.20	0.20
Protective conductors					
Average resistance, cold state (ambient temperature 20 °C)		mΩ/m	0.73	0.73	0.73

Fault loop characteristics

Between live conductors					
Average resistance of loop (thermal stabilisation temp. θ1)	Rb1 ph ph or Rb1 ph N	mΩ/m	10.93	4.41	1.85
Average resistance of loop (1) (short-circuit conventional temp.)	Rb2 ph ph or ph N	mΩ/m	13.26	5.30	2.22
Average reactance of loop	Xb ph ph	mΩ/m	0.75	0.75	0.75
	Xb ph N	mΩ/m	0.95	0.95	0.95
Between live conductor and PE					
Average resistance of loop (thermal stabilisation temp. θ1)	Rb1 ph PE	mΩ/m	6.39	3.07	1.79
Average resistance of loop (1) (short-circuit conventional temp.)	Rb2 (ph PE)	mΩ/m	7.67	6.68	2.15
Average reactance of loop	Xb ph PE	mΩ/m	0.80	0.80	0.80

Other characteristics

Short-circuit withstand capacity										
Permissible rated peak current	/pk	kA	6	11	14					
Maximum thermal limit		A ² s	0.29.10 ⁶	1.8.10 ⁶	8.10 ⁶					
Voltage drop	Voltage drop for 3-phase 50 Hz current expressed in V/100 mA, with load distributed along the run. Where the load is concentrated at the end of the run, the voltage drop is twice the values shown below.									
	For a power factor cos φ of 0.8	V/100 mA	0.389	0.163	0.075					
	For a power factor cos φ of 0.9	V/100 mA	0.433	0.180	0.080					
	For a power factor cos φ of 1.0	V/100 mA	0.473	0.191	0.080					
Normal mounting position	Edgewise (for flat mounting, see page 11021/7)									
Permissible current Iz according to ambient temperature	Derating/uprating factor K1 to be applied to the nominal current (Inc) rating of the trunking where the average daily ambient temperature is other than 35 °C.									
		°C	15	20	25	30	35	40	45	50
	Coefficient (K1)		1.25	1.20	1.13	1.07	1.00	0.93	0.85	0.76
Electrical characteristics of remote control circuit (KNT) (per conductor)	Composition	Cross-section (mm ²)	Ith A	Ui/Ue V	Resistance, cold state mΩ/m	Resistance, hot state mΩ/m				
	3 copper conductors	2.5	6	500	7.5	8.7				

(1) In accordance with CENELEC RO 64-013 publication.

KNA-06AB4, KNA-10AB4

KNA-●●EA4●●, KNA-●●ED4●●

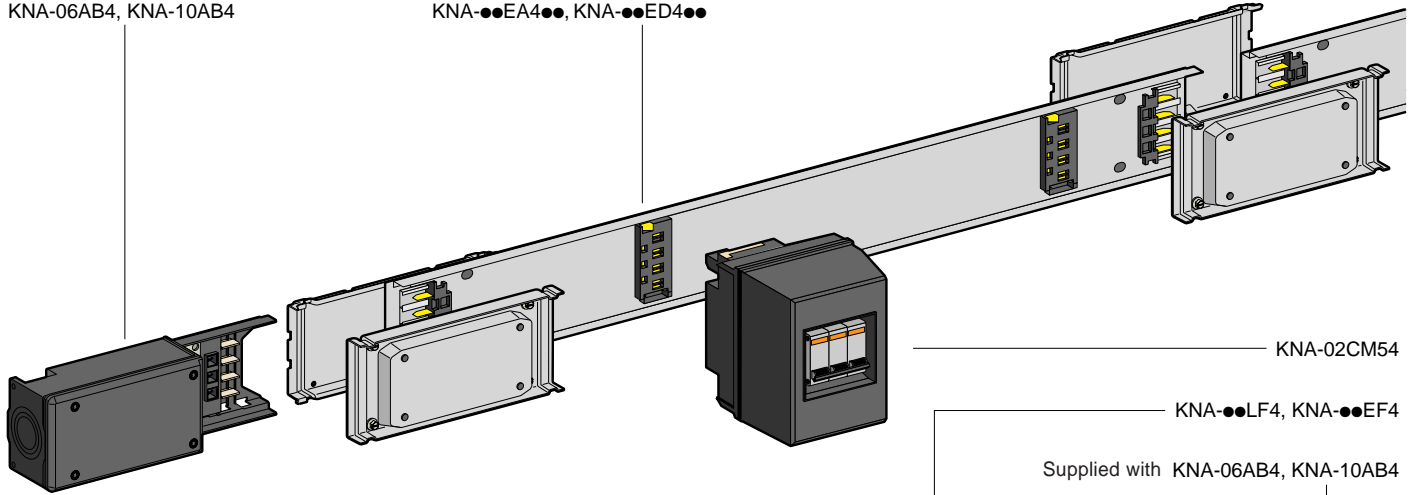

KNA-02CM54

KNA-●●LF4, KNA-●●EF4

Supplied with KNA-06AB4, KNA-10AB4

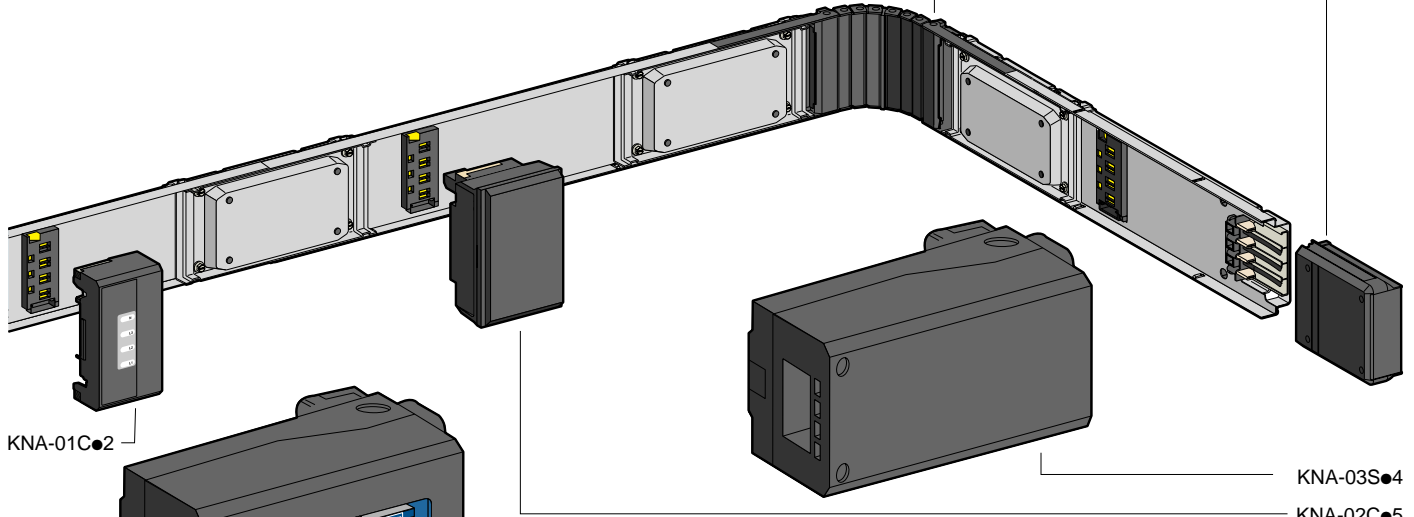

KNA-01C●2

KNA-03S●4

KNA-02C●5

KNA-03SM47

KNA-03SM416

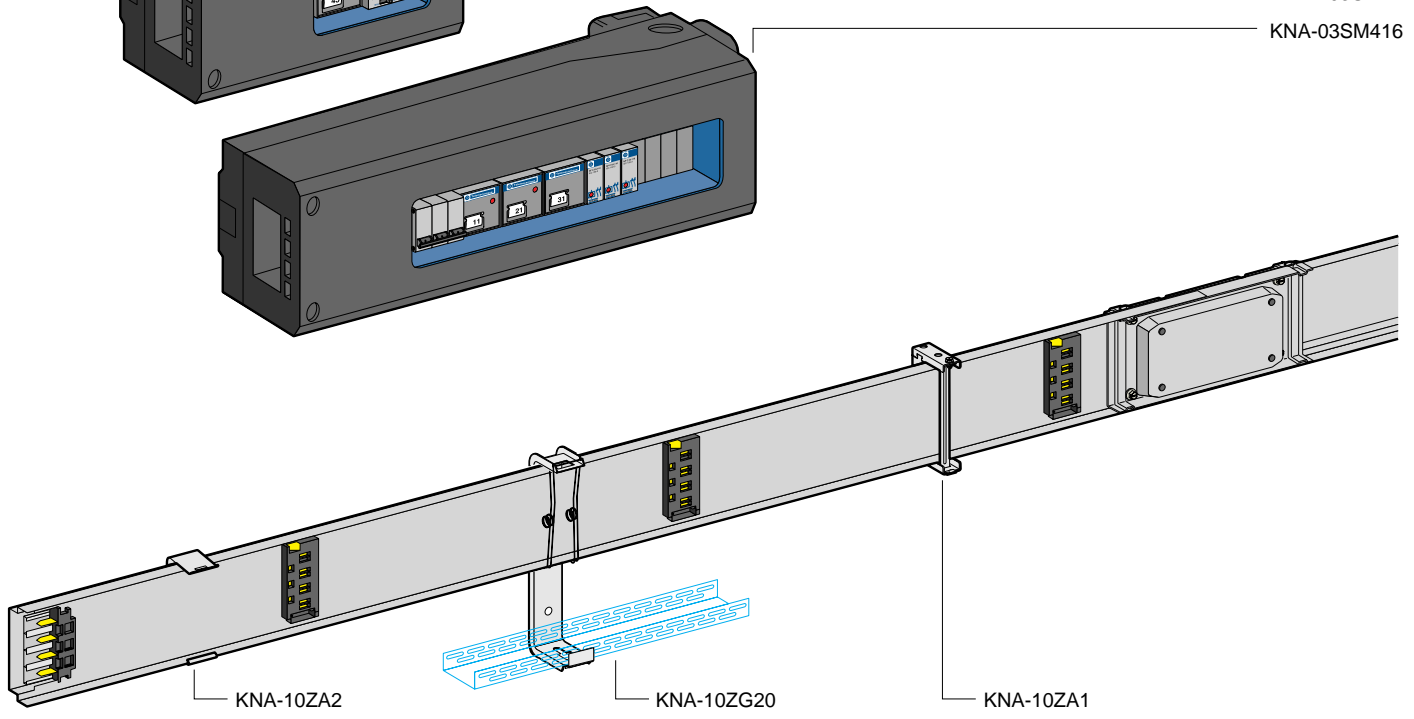

KNA-10ZA2

KNA-10ZG20

KNA-10ZA1

Low power distribution

Description :
pages 11021/2 to 11021/7
Selection guide :
page 11022/2
Characteristics :
page 11022/3
Dimensions :
pages 11029/2 and 11029/3

Canalis KNA (40 to 100 A)

References

Straight lengths - 3L + N + PE

Type of trunking	Rating A	Length m	Number of tap-off units	Reference	Weight kg	
	40	3	3	KNA-04EA430	5.600	
			6	KNA-04ED430	5.600	
		2	4	KNA-06ED420	4.100	
			6	KNA-06EA430	5.700	
		63	3	3	KNA-06EA430	5.700
				6	KNA-06ED430	5.700
	2	4	4	KNA-06ED420	4.100	
			100	3	3	KNA-10EA430
	6	KNA-10ED430			6.700	
	2	4		4	KNA-10ED420	4.800

Feed units with end covers

Description	Rating A	Copper cable connection			Reference	Weight kg
		Type	Max c.s.a. mm ²	Max cable diameter mm		
End feed (1) Mounted on left or right	63 (40)	On junction blocks	16	30	KNA-06AB4	0.580
	100	By cable lugs (M8 screws)	35	40	KNA-10AB4	1.120
Centre feed unit (2) Mounted along the trunking run	63 (40)	On junction blocks	16	24	KNA-06BT4	1.470
	100	By cable lugs (M8 screws)	35	30	KNA-10BT4	2.940

Accessories

Description	Rating A	Actual length m	Reference	Weight kg
Flexible edgewise elbows For internal or external angle from 80° to 180°	63 (40)	0.355	KNA-06LF4	1.200
	100	0.355	KNA-10LF4	1.300
Flexible edgewise lengths To clear obstructions or for length adjustment	63 (40)	1	KNA-06EF4	2.100
	100	1	KNA-10EF4	2.300

Fixing brackets (for all KN trunking)

Description	Sold in lots of	Unit reference	Weight kg
Universal fixing for all types of mounting (Wall, ceiling, suspended on threaded rod, pendant, etc.)	10	KNA-10ZA1	0.130
Wall fixing for surface mounting	10	KNA-10ZA2	0.040
Bracket for suspending additional ducting Maximum width of ducting 50 mm	10	KNA-10ZG20	0.100

Spare parts

Mechanical and electrical jointing device	Rating 63 A (40 A)	–	KNA-06YA4	0.600
	Rating 100 A	–	KNA-10YA4	0.600

(1) Supplied with 1 end cover
(2) Supplied with 2 end covers

KNA-06AB4, KNA-10AB4

KNA-●●EA4●●, KNA-●●ED4●●

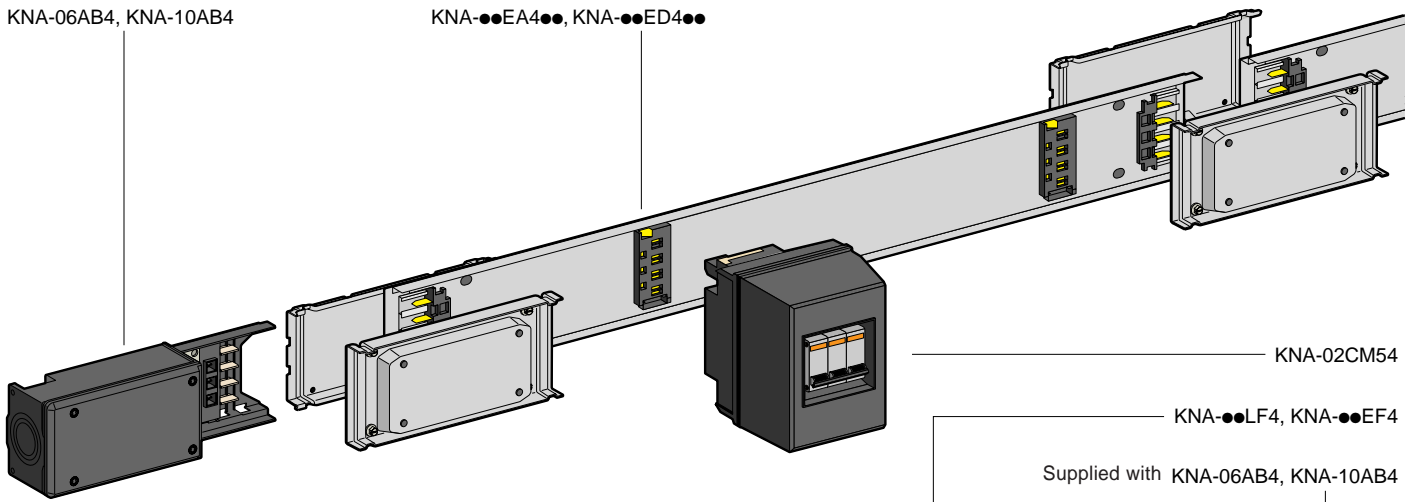

KNA-02CM54

KNA-●●LF4, KNA-●●EF4

Supplied with KNA-06AB4, KNA-10AB4

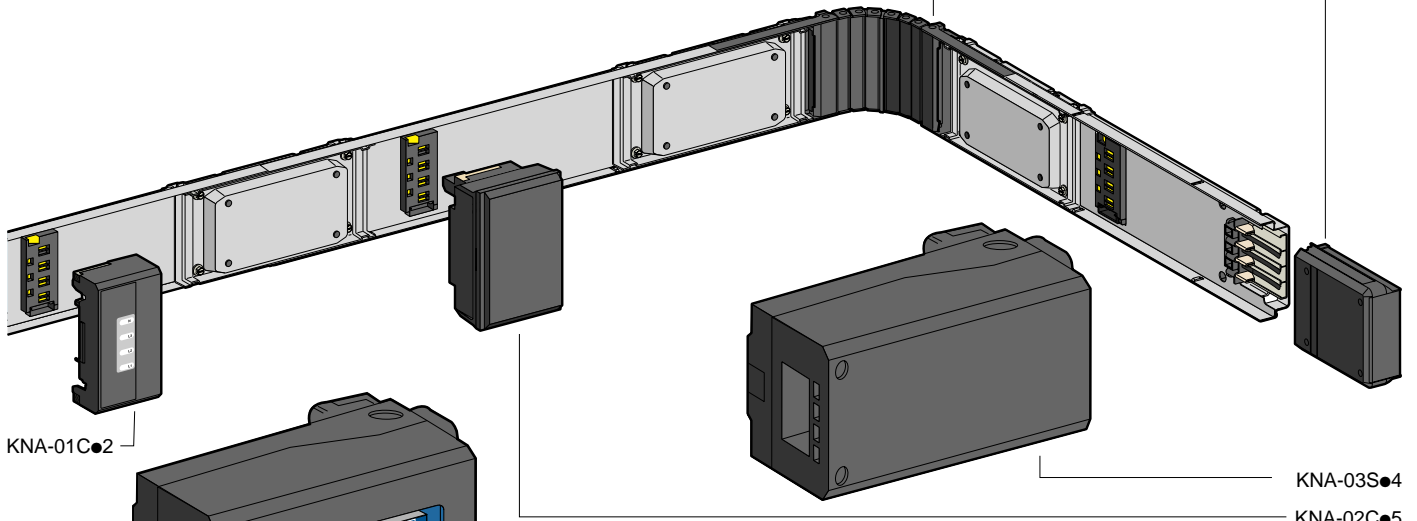

KNA-01C●2

KNA-03S●4

KNA-02C●5

KNA-03SM47

KNA-03SM416

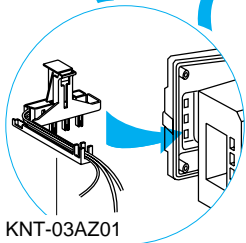
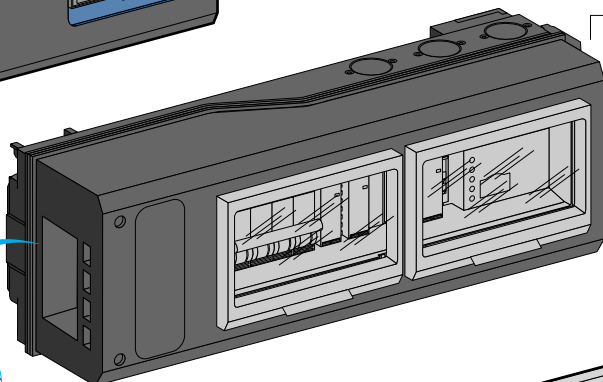
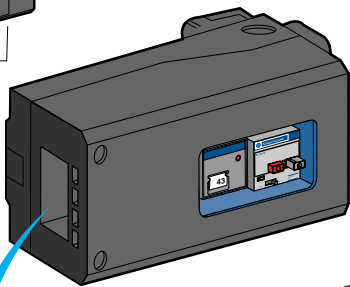

KNT-03AZ01

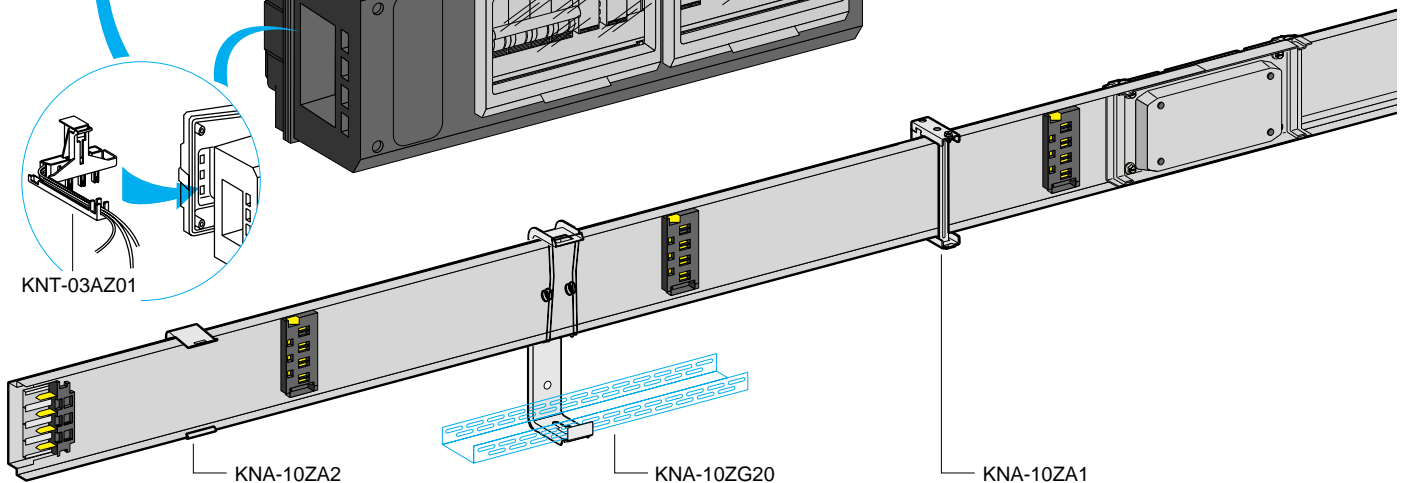

KNA-10ZA2

KNA-10ZG20

KNA-10ZA1

Low power distribution

Description:
pages 11021/2 to 11021/7
Selection guide:
page 11022/2
Characteristics:
page 11022/3
Dimensions:
pages 11029/2 and 11029/3

Canalis KNT (40 to 100 A) Transmission bus

References

Straight lengths - 3L + N + PE

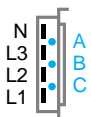
Type of trunking	Rating A	Length m	Number of tap-off units	Reference	Weight kg	
	40	3	3	KNT-04EA430	5.600	
			6	KNT-04ED430	5.600	
	63	3	2	4	KNT-06ED420	4.100
				3	KNT-06EA430	5.700
	100	3	2	4	KNT-10ED420	4.100
				6	KNT-10EA430	6.700
			6	KNT-10ED430	6.700	
			4	KNT-10ED420	4.800	

Feed units with end covers

Description	Rating A	Copper cable connection		Reference	Weight kg	
		Type	Max. c.s.a. mm ²			Max cable diameter mm
End feed (1) Mounted on left or right	63 (40)	To junction blocks	16	30	KNT-06AB4	0.580
	100	By cable lugs (M8 screw)	35	40	KNT-10AB4	1.120
Centre feed unit (2) Mounted along the trunking run	63 (40)	To junction blocks	16	24	KNT-06BT4	1.470
	100	By cable lugs (M8 screw)	35	30	KNT-10BT4	2.940

Accessories

Description	Rating A	Actual length m	Reference	Weight kg
Flexible edgewise elbows For internal or external angle from 80° to 180°	63 (40)	0.355	KNT-06LF4	1.200
	100	0.355	KNT-10LF4	1.300
Flexible edgewise lengths To clear obstructions or for length adjustment	63 (40)	1	KNT-06EF4	2.100
	100	1	KNT-10EF4	2.300

Fixing brackets (for all KN trunking)

Description	Sold in lots of	Unit reference	Weight kg
Universal fixing for all types of mounting (Wall, ceiling, suspended on threaded rod, pendant etc.)	10	KNA-10ZA1	0.130
Wall fixing for surface mounting	10	KNA-10ZA2	0.040
Bracket for suspending additional ducting Maximum width of ducting 50 mm	10	KNA-10ZG20	0.100

Spare parts

Mechanical and electrical jointing device	Rating 63 A (40 A)	—	KNT-06YA4	0.620
	Rating 100 A	—	KNT-10YA4	0.620

(1) Supplied with 1 end cover
(2) Supplied with 2 end covers

Low power distribution

Description:
pages 11021/2 to 11021/7
Selection guide:
page 11022/2
Characteristics:
page 11022/3
Dimensions:
pages 11029/2 and 11029/3

Canalis KN (40 to 100 A)
Connectors and tap-off units for NF fuses

References

Earth connection scheme	TT - TNS	TT - TNS	IT
Output polarity	L + N + PE	3L + N + PE (1)	3L + Np (2) + PE

L + N + PE tap-off units with phase selection

Tap-off scheme
(example : protection by fuse)



Rating A	Device	Reference	Reference	Reference	Weight kg
16	For UTE fuses: 8.5 x 31.5, type gF: 16 A max (Not supplied)	KNA-01CF2	-	-	0.160
	With Merlin Gerin circuit-breaker, type C60N, 1 pole, curve C (3)	KNA-01CD2	-	-	0.380

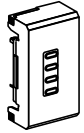

KNA-01CF2

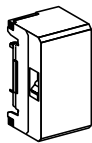

KNA-01CD2

Single phase + N + PE tap-off units with 2 UTE power sockets (2P + PE) 10/16 A

Tap-off scheme
(example: protection by single pole circuit-breaker)

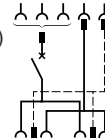

Rating A	With Merlin Gerin circuit-breaker type	Reference	Reference	Reference	Weight kg
16	C60N, 1 pole, curve C (3)	KNA-01CP11	-	-	0.380
	DPN, 1 pole + N, curve U (3)	KNA-01CP21	-	-	0.380

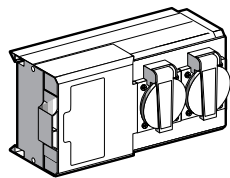

KNA-01CP11

3L + N + PE tap-off unit (1)

Tap-off scheme



Rating A	For NF fuses 10 X 38 (not supplied)	Reference	Reference	Reference	Weight kg
25	Type gG: 20 A max Type aM: 25 A max	-	KNA-02CF5	-	0.380

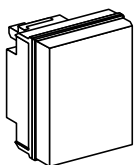

KNA-02CF5

3L + N + PE tap-off unit with isolator (1)

Tap-off scheme

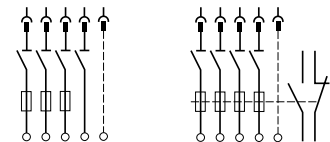

Rating A	For NF fuses 14 x 51 (not supplied)	Reference	Reference	Reference	Weight kg
32	Type gG: 32 A max Type aM: 40 A max	-	KNA-03SF4	KNA-03SF4 (4)	1.380

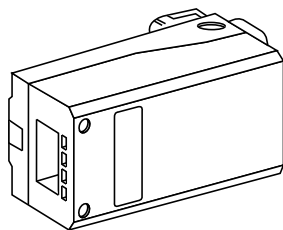

KNA-03SF4

Accessory for tap-off unit with isolator KNA-03SF4

Description	Reference	Weight kg
Single phase protection device	KNA-03EZ20	0.005

(1) Equally suitable for 3L + PE tap-off unit (N not distributed), all TT, TNS and IT schemes.
(2) Np: Neutral protected.
(3) Other circuit-breakers: please consult your Regional Sales Office.
(4) With KNA-03EZ20 and a breaker device placed downstream of the tap-off unit.

Low power distribution

Description:
pages 11021/2 to 11021/7
Selection guide:
page 11022/2
Characteristics:
page 11022/3
Dimensions:
pages 11029/2 and 11029/3

Canalis KN (40 to 100 A)
Connectors and tap-off units for modular equipment

References

Earth connection scheme	TT - TNS	IT
Output polarity	3L + N + PE (1)	3L + Np (2) + PE

Tap-off units for modular equipment (at intervals of 17.5 mm)

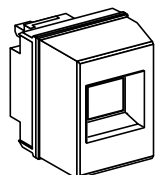

KNA-02CM54

Tap-off scheme
(example: protection by circuit-breaker)



Rating A	Number of modules	Remote control circuit	Cut-out for cover	Reference	Reference	Weight kg
25	4	No	Yes	KNA-02CM54	KNA-02CM54	0.600
			No	KNA-02CX54	KNA-02CX54	0.600
		Yes	Yes	KNT-02CM54	KNT-02CM54	0.600
			No	KNT-02CX54	KNT-02CX54	0.600

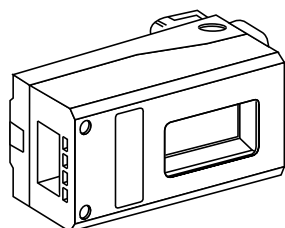

KNA-03SM47

Tap-off units with isolator for modular equipment (at intervals of 17.5 mm)

Tap-off scheme
(example: protection by circuit-breaker)

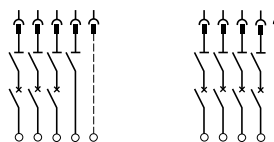

Rating A	Number of modules	Remote control circuit	Cut-out for gate	Reference	Reference	Weight kg
40	7	With KNT-03AZ01	Yes	KNA-03SM47	KNA-03SM47	1.180
			No	KNA-03SX47	KNA-03SX47	1.180
	2 x 7	With KNT-03AZ01	Yes	KNA-03SM42X7	KNA-03SM42X7	1.350
	16	With KNT-03AZ01	Yes	KNA-03SM416	KNA-03SM416	1.500
			No	KNA-03SX416	KNA-03SX416	1.500

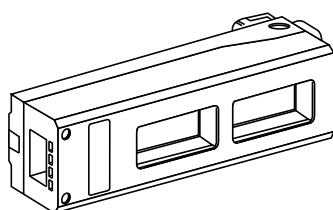

KNA-03SM42X7

Accessories for connectors and tap-off units

Description	Reference	Weight kg		
Remote control power socket block for use with units KNA-03S●●●	KNT-03AZ01	0.055		
Description	Colour	Sold in lots of	Unit reference	Weight kg
Tap-off locating device point/unit	White	10	KNA-03AZ10	0.001
	Red	10	KNA-03AZ20	0.001
	Yellow	10	KNA-03AZ30	0.001
	Blue	10	KNA-03AZ40	0.001

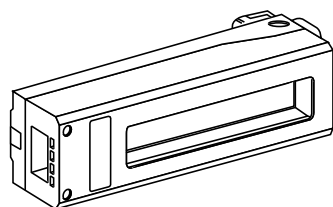

KNA-03SM416

(1) Equally suitable for 3L + PE tap-off unit (N not distributed), all TT, TNS and IT schemes.
(2) Np: Neutral protected.

Low power distribution

Description :
pages 11021/2 to 11021/7
Selection guide :
page 11022/2
Characteristics :
page 11022/3
Dimensions :
pages 11029/2 and 11029/3

Canalis KN (40 to 100 A) Connectors and tap-off units for DIN fuses

References

Earth connection scheme	TT - TNS	TT - TNS
Output polarity	L + N + PE	3L + N + PE (1)

L + N + PE tap-off unit with phase selection

Tap-off scheme
(Example : protection by circuit-breaker)

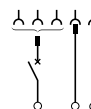

Rating A	With Merlin Gerin circuit-breaker type	Reference	Reference	Weight kg
16	C60N, 1 pole, curve C (2)	KNA-01CD2	-	0.380

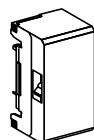

KNA-01CD2

L + N + PE tap-off units with 2 DIN power sockets (2P + PE) 10/16 A

Tap-off scheme
(example : protection by single pole circuit-breaker)

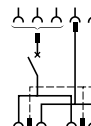

Rating A	With Merlin Gerin circuit-breaker type	Reference	Reference	Weight kg
16	C60N, 1 pole, curve C (2)	KNA-01CP12D	-	0.650

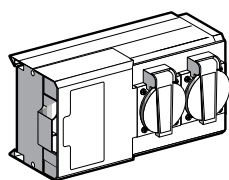

KNA-01CP12D

3L + N + PE tap-off unit (1)

Tap-off scheme

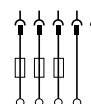

Rating A	For DIN fuses (not supplied)	In max A	Reference	Reference	Weight kg
16	D01 E14 fuses	16	-	KNA-01CD5	0.630

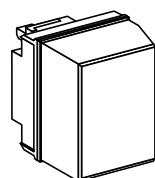

KNA-01CD5

3L + N + PE tap-off units with isolator (1)

Tap-off scheme

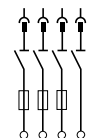

Rating A	For DIN fuses (not supplied)	In max A	Reference	Reference	Weight kg
25	DII E27 fuses	25	-	KNA-02SD4	1.380
35	D02 E18 fuses	35	-	KNA-03SJ4	1.370

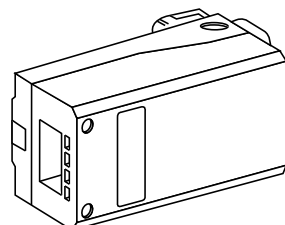

KNA-02SD4

(1) Equally suitable for 3L + PE tap-off unit (N not distributed), all TT, TNS, IT schemes.
(2) Other circuit-breakers : please consult your Regional Sales Office.

Low power distribution

Description:
pages 11021/2 to 11021/7
Selection guide:
page 11022/2
Characteristics:
page 11022/3
Dimensions:
pages 11029/2 and 11029/3

Canalis KN (40 to 100 A)
Connectors and tap-off units for modular equipment

References

Earth connection scheme	TT - TNS	IT
Output polarity	3L + N + PE (1)	3L + Np (2) + PE

Tap-off units for modular equipment (at intervals of 17.5 mm)

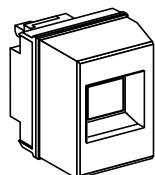

KNA-02CM54

Tap-off scheme
(example: protection by circuit-breaker)

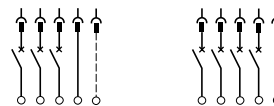

Rating A	Number of modules	Remote control circuit	Cut-out for cover	Reference	Reference	Weight kg
25	4	No	Yes	KNA-02CM54	KNA-02CM54	0.600
			No	KNA-02CX54	KNA-02CX54	0.600
		Yes	Yes	KNT-02CM54	KNT-02CM54	0.600
			No	KNT-02CX54	KNT-02CX54	0.600

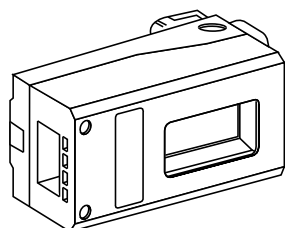

KNA-03SM47

Tap-off units with isolator for modular equipment (at intervals of 17.5 mm)

Tap-off scheme
(example: protection by circuit-breaker)

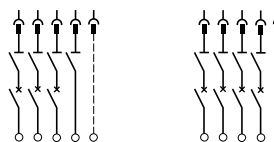

Rating A	Number of modules	Remote control circuit	Cut-out for gate	Reference	Reference	Weight kg
40	7	With KNT-03AZ01	Yes	KNA-03SM47	KNA-03SM47	1.180
			No	KNA-03SX47	KNA-03SX47	1.180
	2 x 7	With KNT-03AZ01	Yes	KNA-03SM42X7	KNA-03SM42X7	1.350
	16	With KNT-03AZ01	Yes	KNA-03SM416	KNA-03SM416	1.500
			No	KNA-03SX416	KNA-03SX416	1.500

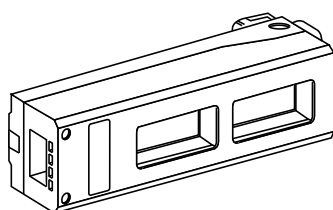

KNA-03SM42X7

Accessories for connectors and tap-off units

Description	Reference	Weight kg		
Remote control power socket block for use with units KNA-03S●●●	KNT-03AZ01	0.055		
Description	Colour	Sold in lots of	Unit reference	Weight kg
Tap-off locating device point/unit	White	10	KNA-03AZ10	0.001
	Red	10	KNA-03AZ20	0.001
	Yellow	10	KNA-03AZ30	0.001
	Blue	10	KNA-03AZ40	0.001

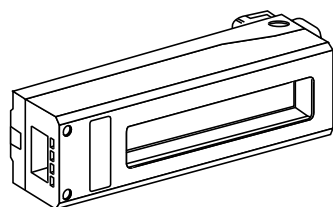

KNA-03SM416

(1) Equally suitable for 3L + PE tap-off unit (N not distributed), all TT, TNS and IT schemes.
(2) Np: Neutral protected.

Low power distribution

Description :
pages 11021/2 to 11021/7
Selection guide :
page 11022/2
Characteristics :
page 11022/3
Dimensions :
pages 11029/2 and 11029/3

Canalis KN (40 to 100 A)
Connectors and tap-off units for BS fuses

References

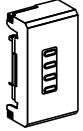

KNA-01CG2

Earth connection scheme	TT - TNS	TT - TNS
Output polarity	3L + N + PE	3L + N + PE (1)

L + N + PE tap-off units with phase selection

Tap-off scheme
(Example : protection by fuse)

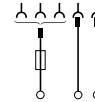

Rating A	With Merlin Gerin circuit-breaker type	For fuses type (not supplied)	In max A	Reference	Reference	Weight kg
16	-	BS88 A1	16 A	KNA-01CG2	-	0.180
	C60H, 1 pole, curve C (2)	-	-	KNA-01CD2	-	0.340

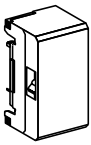

KNA-01CD2

L + N + PE tap-off units with 1 BS power socket (2P + PE) 13 A

Tap-off scheme
(example : protection by single pole circuit-breaker)

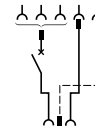

Rating A	With Merlin Gerin type circuit-breaker	Reference	Reference	Weight kg
16	C60N, 1 pole, curve C (2)	KNA-01CP16	-	0.650

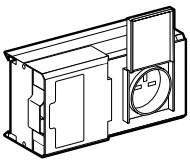

KNA-01CP16

3L + N + PE tap-off unit (1)

Tap-off scheme

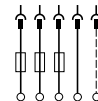

Rating A	For fuses type (not supplied)	In max A	Reference	Reference	Weight kg
20	BS88 A1	20	-	KNA-02CG5	0.400

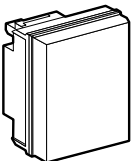

KNA-02CG5

3L + N + PE tap-off unit with isolator (1)

Tap-off scheme

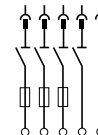

Rating A	For fuses type (not supplied)	In max A	Reference	Reference	Weight kg
32	BS88 A1	30 A	-	KNA-03SG4	1.480

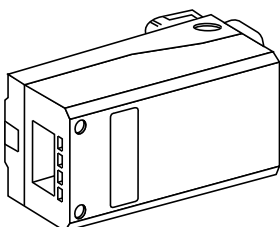

KNA-03SG4

(1) Equally suitable for 3L + PE tap-off unit (N not distributed), all TT, TNS, IT schemes.
(2) Other circuit-breakers : please consult your Regional Sales Office.

KNE-06YB1, KNE-10YB1

2 x KNE-06YB1, 2 x KNE-10YB1

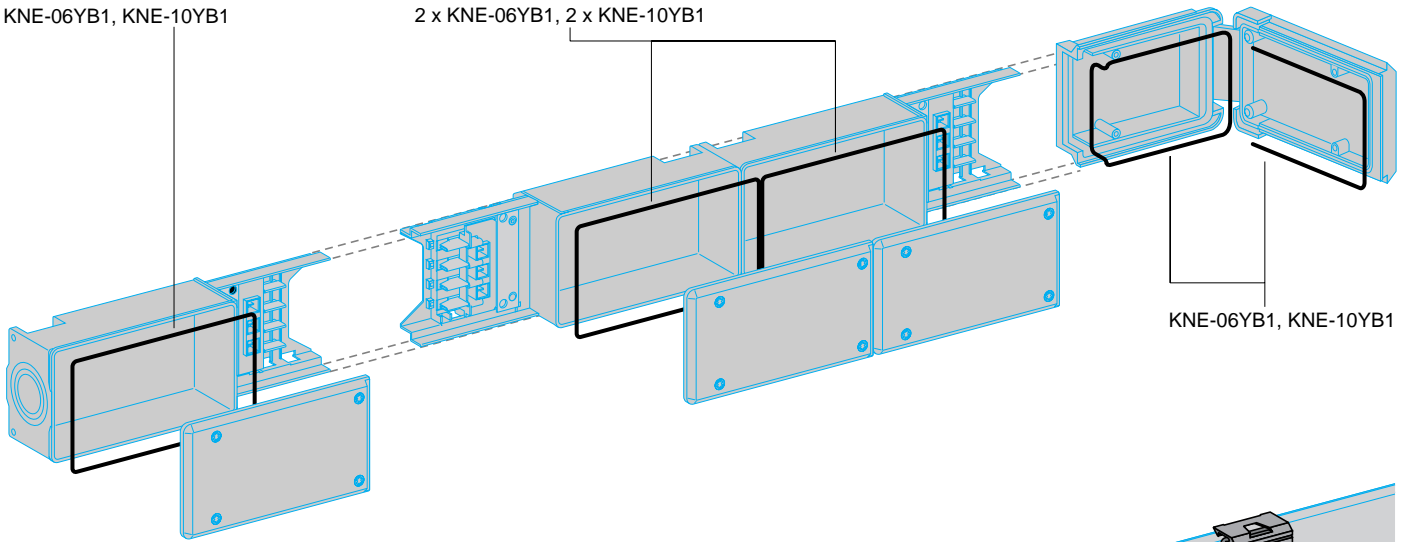

KNE-06YB1, KNE-10YB1

KNE-10YA1

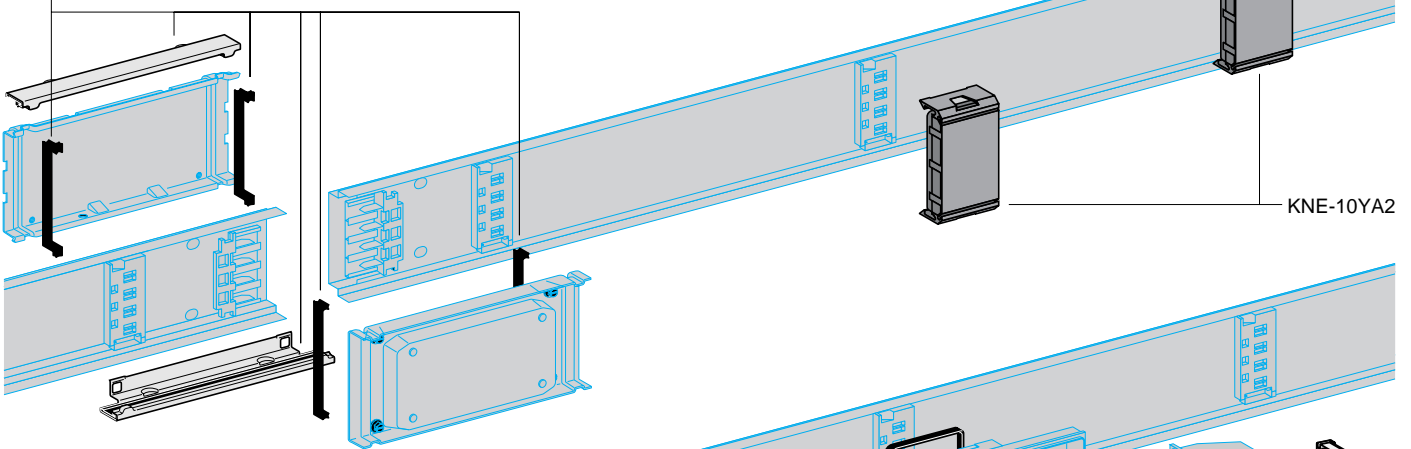

KNE-10YA2

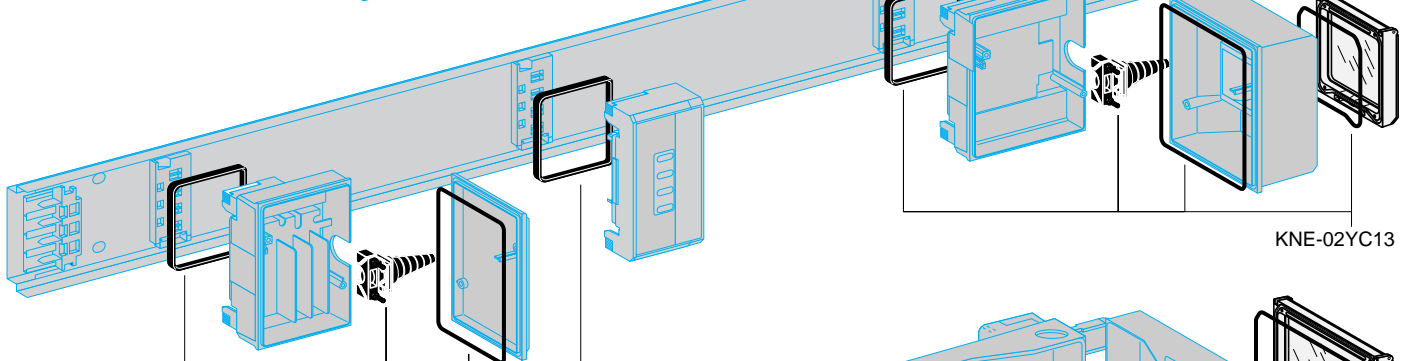

KNE-02YC13

KNE-02YC12

KNE-01YC10

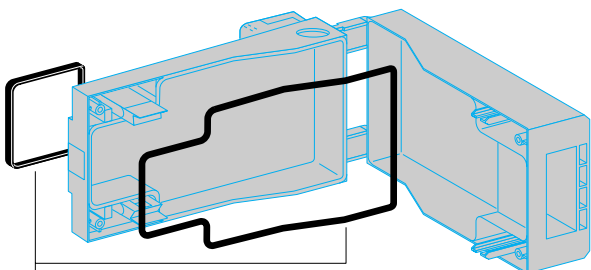

KNE-03YC14

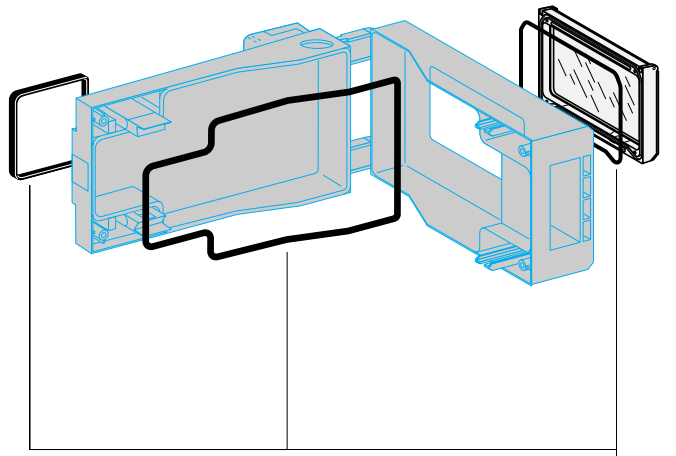

KNE-03YC15

Low power distribution

Description :
pages 11021/2 to 11021/5
Selection guide :
page 11022/2
Characteristics :
page 11022/3
Dimensions :
pages 11029/2 and 11029/3

Canalis KN (40 to 100 A)
Dust and damp protection accessories and sealing accessories

References

Dust and damp protection accessories common to KNA/KNT (integrated remote control bus)

Description	Rating	Actual length	Reference	Weight
	A	m		kg
Flexible edgewise elbows For internal or external angle from 80° to 180°	63 (40)	0.355	KNE-06LF4	1.200
	100	0.355	KNE-10LF4	1.300
Flexible edgewise lengths To clear obstructions or for length adjustment	63 (40)	1	KNE-06EF4	2.100
	100	1	KNE-10EF4	2.300

Sealing accessories for straight lengths

Description	Sold in lots of	Unit reference	Weight
			kg
Joint sealing kit (1 per length, straight or flexible)	1	KNE-10YA1	0.150
Tap-off blanking plate (1 per unused tap-off)	5	KNE-10YA2	0.030

Sealing accessories for feed units

Description	Rating	Reference	Weight
	A		kg
For end feed unit and end cover (for centre feed unit and end cover, order 2 items)	63 (40)	KNE-06YB1	0.010
	100	KNE-10YB1	0.010

Sealing accessories for connectors and tap-off units

Description	Reference	Weight
		kg
Kit for connectors KNA-01CF2 and KNA-01CG2	KNE-01YC10	0.010
Kit for connectors KNA-01CD5, KNA and KNT-02CX54	KNE-01YC11	0.010
Kit for connectors KNA-02CF5, KNA-02CG5	KNE-02YC12	0.040
Kit for connectors KNA and KNT-02CM54	KNE-02YC13	0.095
Kit for enclosures KNA-03SF4, KNA-03SG4, KNA-02SD4/SJ4 and KNA-03SX47	KNE-03YC14	0.015
Kit for enclosure KNA-03SM47	KNE-03YC15	0.085
Kit for enclosure KNA-03SM42X7	KNE-03YC2X7	0.190

Other versions

Dust and damp protected tap-off units with isolator for 16 unit modular equipment
Please consult your Regional Sales Office.

Low power distribution

Description:
pages 11021/2 to 11021/7
Selection:
page 11022/2
Characteristics:
page 11022/3
References:
pages 11023/3 to 11028/3

Canalis KN (40 to 100 A)

Dimensions

Straight lengths

KNA-●●EA430, KNT-●●EA430

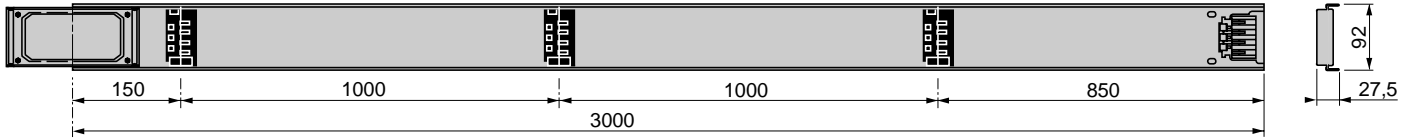

KNA-●●ED430, KNT-●●ED430

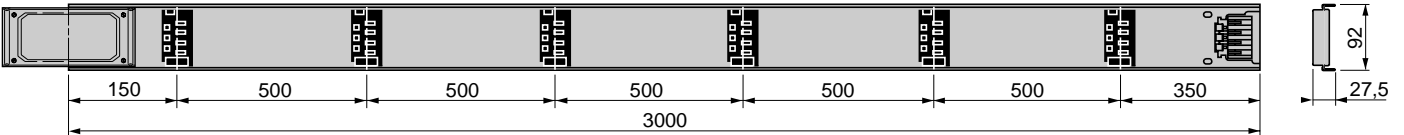

KNA-●●ED420, KNT-●●ED420

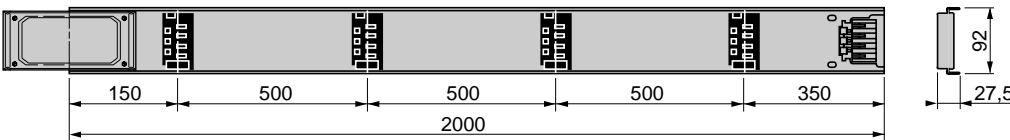

Feed units

KNA-06AB4, KNT-06AB4

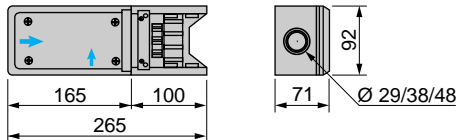

KNA-10AB4, KNT-10AB4

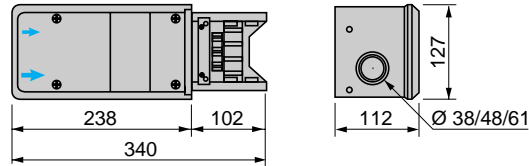

KNA-06B4●, KNT-06B4●

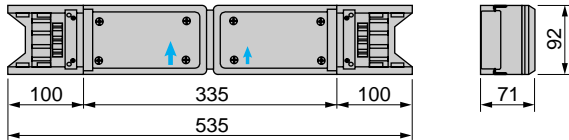

KNA-10BT4, KNT-10BT4

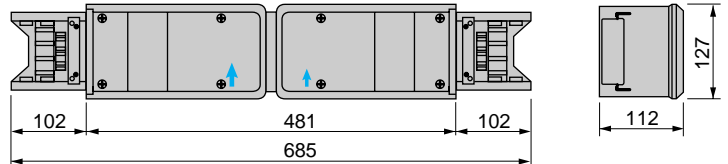

Power cable supply

	KN●-06AB4			KN●-10AB4			KN●-06BT4		KN●-10BT4
Ø drilled and pre-punched	29	38	48	38	48	61	38		48
For cable glands Pg n° .. (not supplied)	21	29	36	29	36	48	29		36
Ø min/max cable	14/18	18/24	24...30	18...24	24...30	35...40	18...24		24...30

Remote control supply cable KNT: Pg 13

Make-up lengths

KNA-●●LF4, KNT-●●LF4

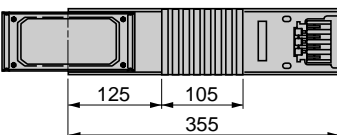

KNA-●●EF4, KNT-●●EF4



Fixing brackets

KNA-10ZA1

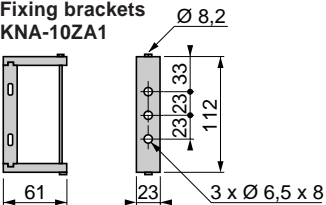

KNA-10ZA2

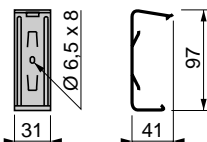

KNA-10ZG20

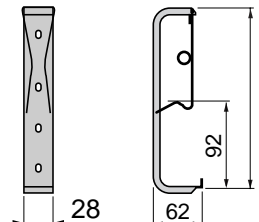

Low power distribution

Canalis KN (40 to 100 A)

Dimensions

Description:
pages 11021/2 to 11021/7
Selection:
page 11022/2
Characteristics:
page 11022/3
References:
pages 11023/3 to 11028/3

Tap-off units

KNA-01CF2, KNA-01CG2

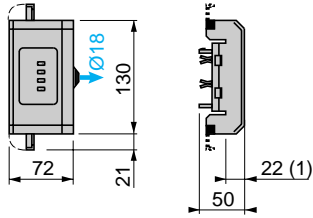

KNA-02CF5, KNA-02CG5

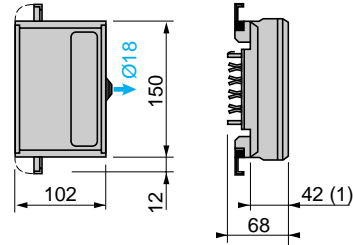

KNA-01CD2

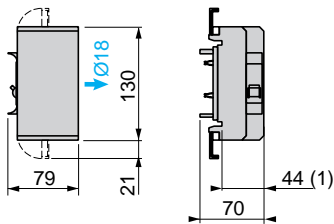

KNA-01CD5

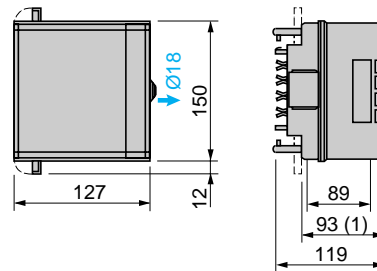

KNA-02CM54, KNT-02CM54

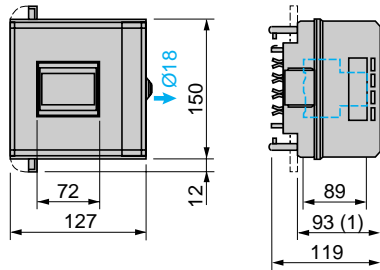

KNA-01CP●●

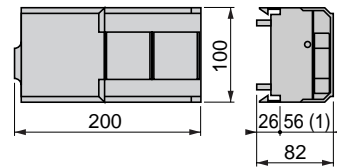

Tap-off enclosures with isolator

KNA-03SM●7

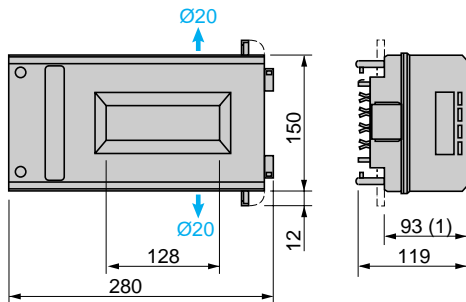

KNA-03SF●, KNA-03SJ●, KNA-03SG4, KNA-02SD●

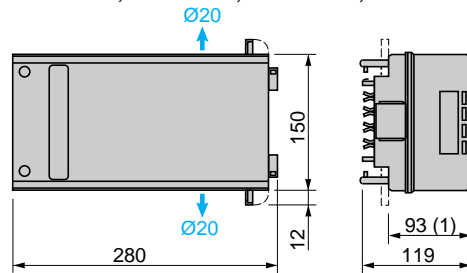

KNA-03SM●2X7

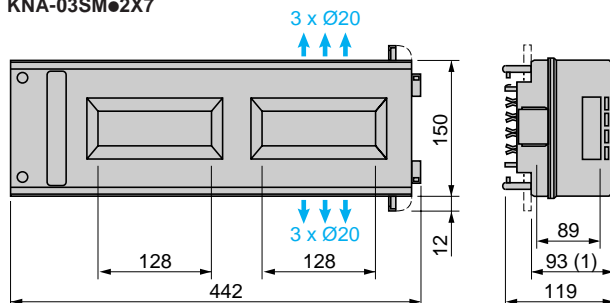

KNA-03SM●16

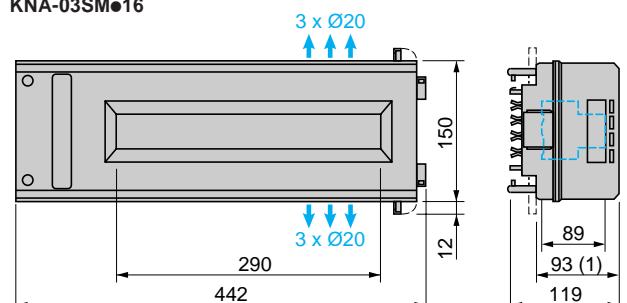

(1) Side projection
→ Cable entry